

**PULLEYS & COMPONENTS**  
**for polyurethane timing belt drives**



# Advice

## Important advice for catalogue users

Please note that this catalogue contains the theoretical pitch circle diameters  $d_0$  for timing pulleys and idlers, whereas the Mulco belt-pilot programme uses the real values for online calculations.

Calculations made with reference to the catalogue data apply solely to polyurethane timing belt drives using BRECO®, BRECOFLEX® and CONTI® SYNCHROFLEX polyurethane timing belts. Subject to change in the course of technical product development.

BRECO®/BRECOFLEX®  
are registered trademarks of  
BRECO Antriebstechnik Breher GmbH & Co. KG,  
Kleiststraße 53, 32457 Porta Westfalica, Germany.

CONTI® SYNCHROCHAIN/CONTI® SYNCHROFLEX  
are registered trademarks of  
ContiTech Antriebssysteme GmbH,  
Vahrenwalder Straße 9, 30165 Hannover, Germany.

MULCO® is a registered trademark of  
Wilhelm Herm. Müller GmbH & Co. KG,  
Heinrich Nordhoff-Ring 14, 30826 Garbsen, Germany.

© 2014 MULCO-Europe EWIV. All rights reserved.  
Reproduction of the entirety of text or parts prohibited.

# Contents

## **4-17 Timing Pulleys and Components**

- 4 Timing belt pulleys
- 5 Pulley pitch range
- 10 Pulley Tooth Design – Overview
- 12 Materials, Overview
- 14 Ordering information
- 18 ATN system components
- 24 Timing pulleys AT-Profile
- 32 Timing pulleys ATP-Profile
- 36 Timing pulleys self-tracking Profiles
- 64 Timing pulleys T-Profile
- 74 Timing pulleys Imperial-Profiles
- 84 Timing pulleys Special Profiles K 1.5
- 86 Timing pulley bars
- 96 Timing pulley bars with hubs
- 100 Shaft locking elements for timing pulleys
- 102 Tensioners
- 110 Clamp plates
- 114 Guide rails

## **118-121 Service and Accessories**

- 118 Mulco belt-pilot programme
- 119 Polyurethane timing belt welder
- 120 List of Catalogues
- 123 Addresses

# Timing belt pulleys

## Complete belt drive solutions

### End-to-end product range

Mulco supplies a complete range of pulleys and other components carefully integrated with their entire portfolio of timing belts. The standard stock range includes more than 3,500 different pulleys, tensioners, tension plates, clamping plates, and guide rails. Almost any combination of materials - be it aluminum, conventional steel alloys, stainless steel or plastic materials - can be turned into high-quality belt drive components. Surfaces are treated by anodizing, hard anodizing, hard coating, galvanizing, burnishing, phosphating, plasma plating, nitro-carburizing and other common methods.

### Off-the-shelf and fully customized products

Timing belt operation is significantly impacted by the quality of the pulleys. Technically speaking, volume production of the standardized Mulco range of pulleys is therefore just as sophisticated as the design and production of pulleys and components to customers specifications. Thus, this strategic commitment not only relies on high-levels of quality but also on fast delivery - worldwide.

### Mulco belt-pilot

Our interactive Internet programme enables you to generate your personal design solutions online. Whatever field of technology you are interested in - power transmission, linear, transport or components - use Mulco belt-pilot at [www.mulco.net](http://www.mulco.net) for 24/7 access to the actual product information, CAD downloads and calculations you need.

### High quality standards

Mulco's factories manufacturing pulleys and components rely on the latest-generation Profilators. High precision, flexible manufacturing and fast throughput are ensured by machines with automatic feeders able to take multiple process steps, i. e. polygon machining, spline cutting or tooth shaping machining, to 1/100th of a millimetre accuracy. Downstream measurement from simple inspection of finished parts to modern conturoscope scanning (at a resolution of 1/1000th of a millimetre) to 3D measuring equipment make sure that the exactly defined quality standards are met. All pulley manufacturers contributing to the Mulco range are certified according to DIN EN ISO 9001:2000.





# Pulley pitch range

## Pulley pitch range - Overview

ATN-Series	AT-Series	ATP-Series	Standard Pulley ATL-Series	T-Series	Selftracking - Series
<ul style="list-style-type: none"> <li>◊ ATN 10</li> <li>◊ ATN 12.7</li> <li>◊ ATN 20</li> </ul>	<ul style="list-style-type: none"> <li>◊ AT 3</li> <li>◊ AT 5</li> <li>◊ AT 10</li> <li>◊ AT(S) 15</li> <li>◊ AT 20</li> </ul>	<ul style="list-style-type: none"> <li>◊ ATP 10</li> <li>◊ ATP 15</li> </ul>	<ul style="list-style-type: none"> <li>◊ ATL 5</li> <li>◊ ATL 10</li> <li>◊ ATL 20</li> </ul>	<ul style="list-style-type: none"> <li>◊ T 2</li> <li>◊ T 2.5</li> <li>◊ T 5</li> <li>◊ T 10</li> <li>◊ T 20</li> </ul>	<ul style="list-style-type: none"> <li>◊ TK5 K6</li> <li>◊ TK10 K6</li> <li>◊ TK10 K13</li> <li>◊ TK20 K13</li> <li>◊ ATK5 K6</li> <li>◊ ATK10 K6</li> <li>◊ ATK10 K13</li> <li>◊ ATK20 K13</li> <li>◊ ATN10 K6</li> <li>◊ ATN12.7 K6</li> <li>◊ L K13</li> <li>◊ H K13</li> </ul>
Selftracking SFAT-Series	HTD/STD-Series	CTD-Series	Imperial-Series	K-Series	
<ul style="list-style-type: none"> <li>◊ SFAT 10</li> <li>◊ SFAT 15</li> <li>◊ SFAT 20</li> </ul>	<ul style="list-style-type: none"> <li>◊ HTD 3M*)</li> <li>◊ HTD 5M*)</li> <li>◊ HTD 8M*)</li> <li>◊ HTD 14M*)</li> <li>◊ STD S3M*)</li> <li>◊ STD S5M*)</li> <li>◊ STD S8M*)</li> </ul>	<ul style="list-style-type: none"> <li>◊ CTD - C8M</li> <li>◊ CTD - C14M</li> </ul>	<ul style="list-style-type: none"> <li>◊ M / MXL / Mini-Pitch</li> <li>◊ XL</li> <li>◊ L</li> <li>◊ H</li> <li>◊ XH</li> <li>◊ XXH</li> </ul>	<ul style="list-style-type: none"> <li>◊ K 1</li> <li>◊ K 1.5</li> </ul>	

\*) Conti C-toothform.  
Further profiles and  
types on request.

### High power profiles with curved-teeth - self-tracking

- ◊ BAT 10
- ◊ BATK 10
- ◊ BAT 15
- ◊ BATK 15

Special requirements  
upon request.



# Pulleys ... Made-To-Order

- **Modern CNC-Technology**
- **Pulleys Made To Specification**

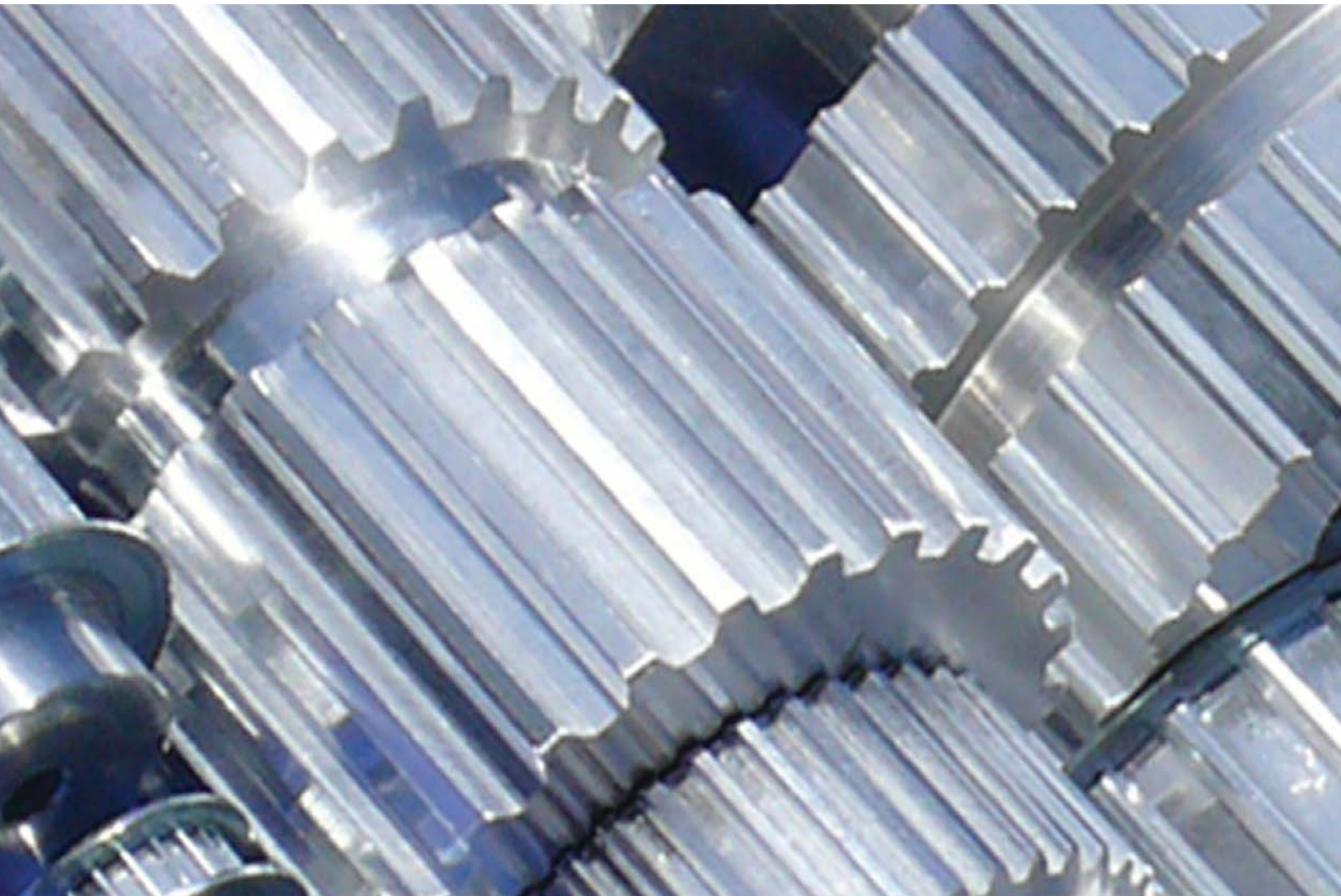

- **Superior Quality Manufacturing**
- **Outstanding Product Performance**



- **DIN EN ISO 9001 ff Certified**
- **Prototyping – Short Runs - Production**



- **Perfect Meshing of Pulley and Timing Belt**

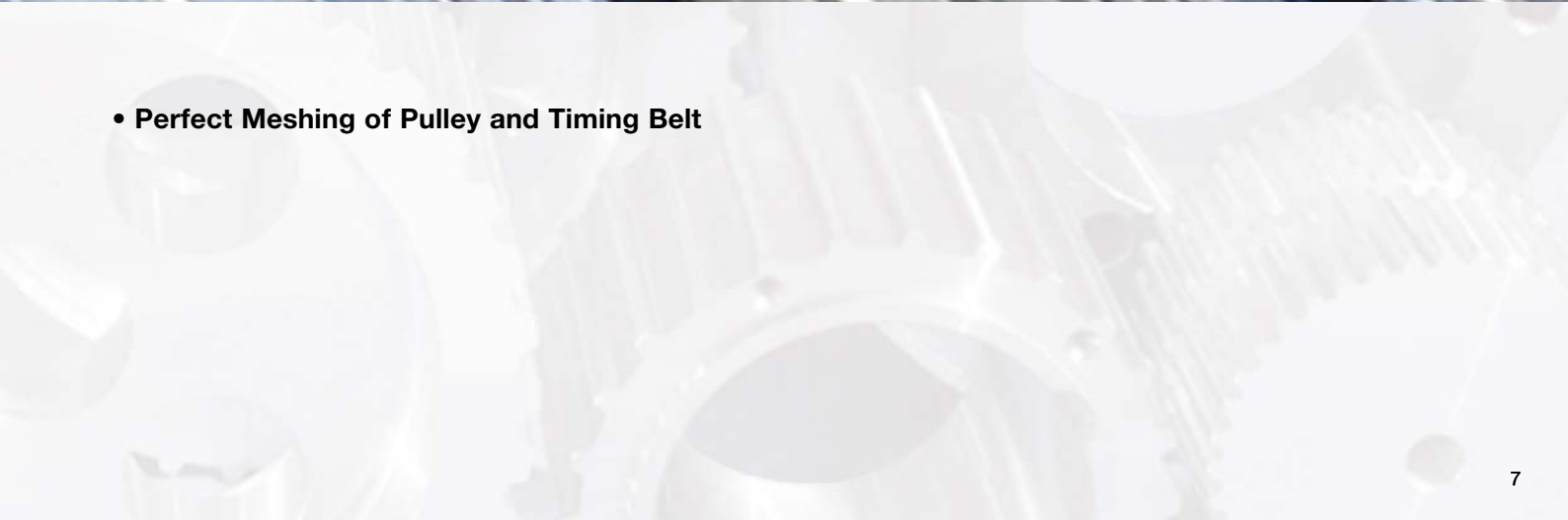

# Pulleys ... Made-To-Order

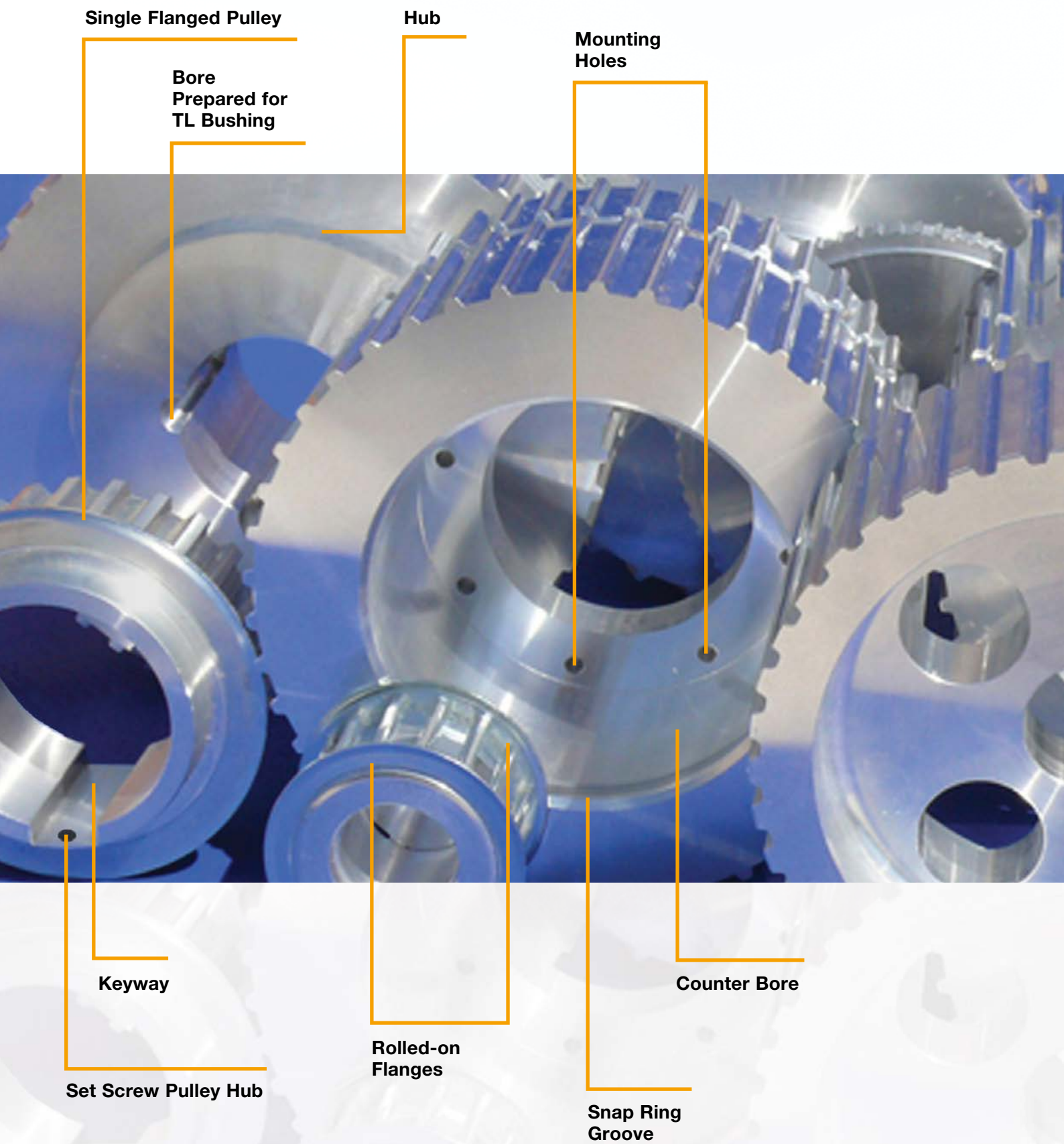





**Set Screw Pulley Face**

**Mounting Holes**

**Screwed-on Flanges**

**Threaded and Through Holes for QD Bushing**

**Lightening Holes**

**Bolt Hole Circle**

**Self-Tracking Groove**

**Un-Flanged Pulley**

**Pilot Bore**



# Pulley Tooth Design – Overview

## Pulley tooth design versions available

Selecting a special pulley tooth gap can increase the accuracy of the timing belt system by decreasing or eliminating “play” between the timing belt and the pulley. Linear drives and systems requiring precise positioning and high repeatability or fast settling times can benefit from reduced

“play”. The illustrations below show the meshing of the timing belt with the tooth gap designs available for metric pitches. For drive designs using “SE” or “0” – tooth gap pulleys, please consult your Mulco-Partner.

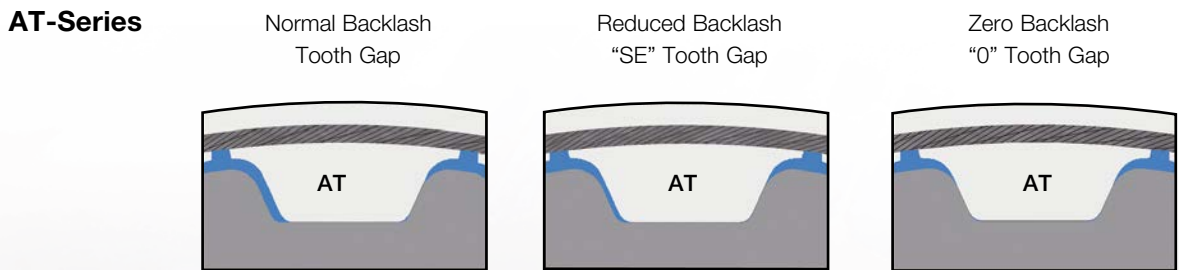
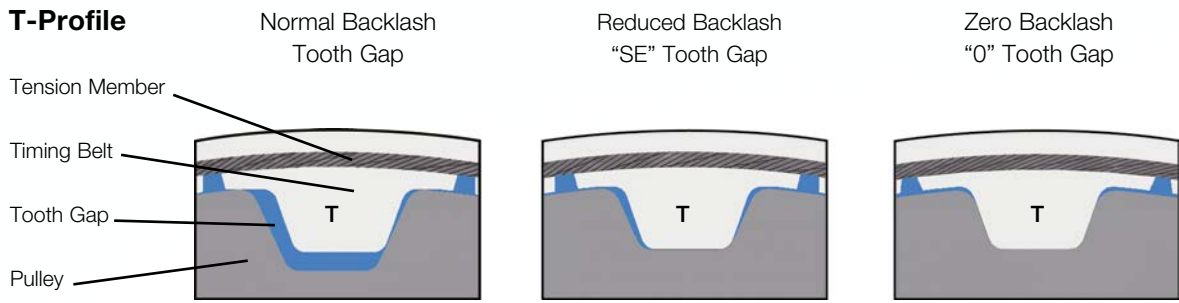

### BELT ELEVATION AND CONTACT SURFACE COMPARISON

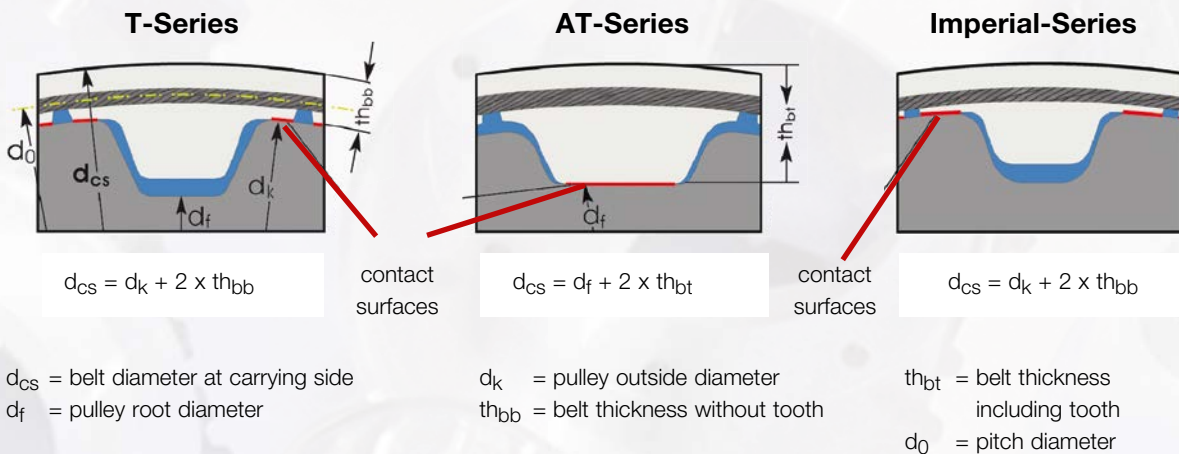

## Standard and optional Pulley Tooth Designs

**We offer three pulley tooth designs for metric pitches as follows:**

- Normal Backlash
- Reduced Backlash “SE”
- Zero Backlash “0”

**Standard** – Standard tooth design will be supplied if no options are specified when ordering.

**Optional** – Optional tooth design must be specified at the time of ordering, otherwise the standard tooth gap design will be provided.

The charts below show the standard and optional tooth designs based on the Number of Pulley Teeth.

### Metric T-Series

Tooth Gap Designs	Pulley < 20 teeth	Pulley > 20 teeth
Normal Backlash	Optional	Standard
Reduced Backlash “SE”	Standard	Optional
Zero Backlash “0”	Optional	

### AT-Series excluding AT20

Tooth Gap Designs	# of Pulley Teeth “All”
Normal Backlash	Standard
Reduced Backlash “SE”	Optional
Zero Backlash “0”	Optional

### T-Series Tooth Gap ordering examples

#### Normal Backlash

# of teeth < 20: AL 40 T10 – SE / 18 – 2

# of teeth > 20: AL 40 T10 / 24 – 2

For pulleys with < = 20 teeth Reduced Backlash “SE” is standard. Normal Backlash is only available for pulleys with > 20 teeth.

#### Reduced Backlash “SE”

# of teeth < 20: AL 40 T10 – SE / 18 – 2

# of teeth > 20: AL 40 T10 – SE / 24 – 2

Reduced Backlash “SE” is standard for pulleys < 20 teeth. For pulleys > 20 teeth Reduced Backlash “SE” must be specified.

#### Zero Backlash “0”

# of teeth < 20: AL 40 T10 – 0 / 18 – 2

# of teeth > 20: AL 40 T10 – 0 / 24 – 2

Zero Backlash “0” must be specified for all pulleys.

### AT-Series Tooth Gap ordering examples

#### Normal Backlash

# of teeth – All: AL 42 AT10 / 24 – 2

Normal Backlash is standard for all pulleys.

#### Reduced Backlash “SE”

# of teeth – All: AL 42 AT10 – SE / 24 -2

Reduced Backlash “SE” must be specified for all pulleys.

#### Zero Backlash “0”

# of teeth – All: AL 42 AT10 – 0 / 24 -2

Zero Backlash “0” must be specified for all pulleys.

# Materials, Overview

## Materials

### Aluminum (AL)

- Suitable for moderate power transmission
- Low weight / reduced rotational inertia
- Average chemical and corrosion resistance
- RoHS-compliant standard material (for stock pulleys)  
AlCu4MgSi (A), EN AW-2017A and AlZn5Mg3Cu,  
EN AW-7022 (for ATP10, ATP15)



Further materials upon request.

### Stainless steel (VA)

- Suitable for high power
- Durable / abrasion resistant
- Meets FDA regulations
- Excellent chemical and corrosion resistance

### Steel (ST)

- Suitable for high power
- Durable / abrasion resistant
- Limited chemical and corrosion resistance
- Standard SMn30 material 11, material no. 1.0715  
EN 10 277; ck45/c45e, material no. 1.1191 EN 10083

### Delrin (POM)

- Limited power transmission
- Excellent chemical and corrosion resistance
- Non-Metallic
- Stainless steel flanges recommended

## Surface treatments

### Aluminum

#### Anodized

- Increased chemical and corrosion resistance
- Available in clear, black or colored
- Limited increase in surface hardness

#### Hard anodized

- Excellent chemical and corrosion resistance
- Increased surface hardness
- Resistant to abrasion

Other surface finishes upon request.

### Steel

#### Black Oxide

- Increased chemical and corrosion resistance

#### Galvanized

- Enhanced corrosion resistance

#### Chrome-plated

- Increased chemical and corrosion resistance

#### Nickel-plated

- Increased chemical and corrosion resistance
- Balancing according to DIN ISO 1940

## Flanges

Zinc plated steel is used as the standard material. Special versions to user requirements.

Mounting is achieved by rolling, crimping or screwing depending on the tooth profile and number of teeth.

The belt width  $b$  is dependent on the pulley width  $B$  to guarantee sufficient width clearance. This clearance is not dimensioned separately.

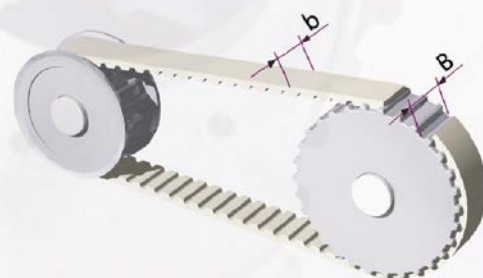

## Tolerances

The central pulley bore is produced to H7 tolerance unless otherwise requested. All untoleranced dimensions are manufactured to the tolerance class “medium” according to DIN 7168.

## Minimum number of pulley teeth and tension roller diameters

Information on minimum number of teeth and minimum diameters are listed in the catalogues for BRECO®, BRECOFLEX®, CONTI® SYNCHROFLEX and CONTI® SYNCHROCHAIN polyurethane timing belts.

## Belt widths relative to pulley tooth widths

### Metric tooth profiles

Belt width (mm)	4	6	8	10	16	20	25	32	50	75	100	150
Flanged/unflanged timing pulleys												
Pulley tooth width (mm)	8	12	14	16	22	26	32	40	60	85	110	160
Self-tracking timing pulleys												
Pulley tooth width (mm)	-	-	-	-	21	25	30	37	55	80	105	155

# Ordering information

The production of timing pulleys is subject to a continuous quality control. Timing pulleys are generally hobbled. Optimum function is reached by precisely generating toothforms and achieving pitch uniformity.

The material and dimensions of the timing pulley such as number of teeth, pulley width, bore and flange arrangement are defined by the customer. Below, recommendations for the designer can be found.

---

## How to find a stock pulley

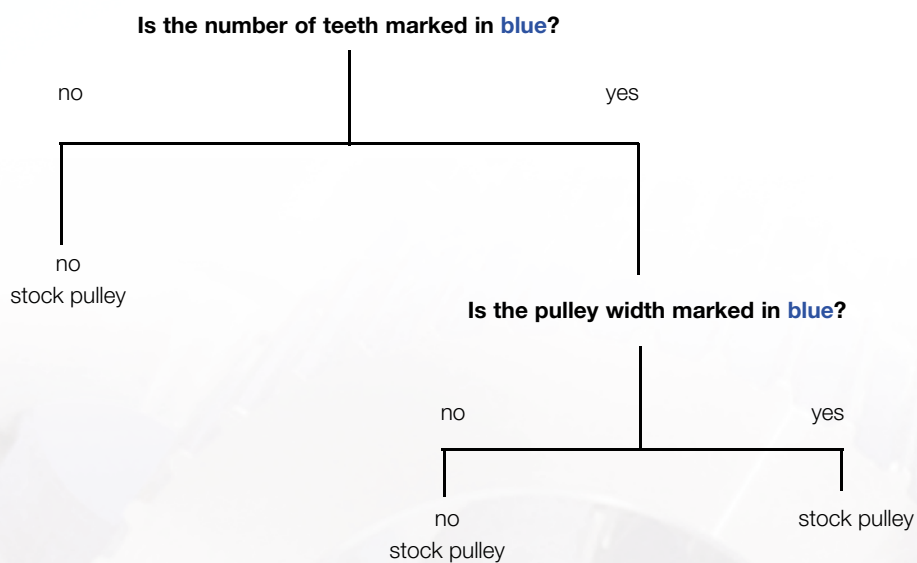



**Order example:**

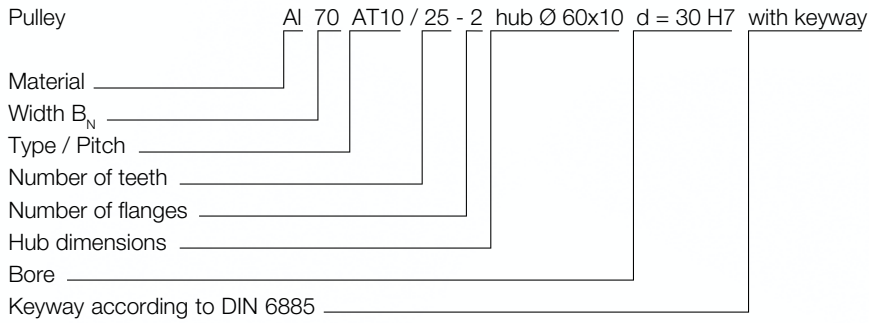

Even without supplying a drawing you are able to get a functional and quality product relating to our timing belt program by using our standard order text.

You will find sample order texts for various pulley versions linked to the following drawings.

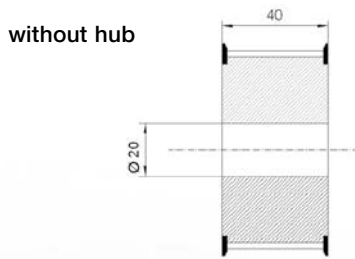

Order text: Timing pulley  
AI 40 AT 10/24-2  
d = 20 H7

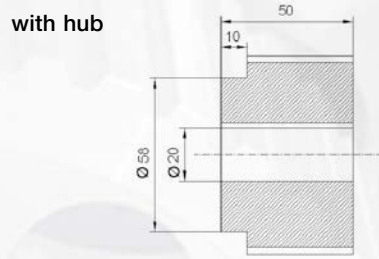

Order text: Timing pulley  
AI 50 AT 10/24-0  
Hub Ø 58 x 10  
d = 20 H7 with keyway

# Ordering information

## Position and number of flanges

### Number of flanges: 2

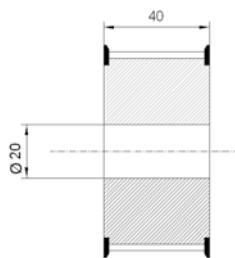

Order text: Timing pulley  
AI 40 AT 10/24-2  
d = 20 H7

### Bore fastening

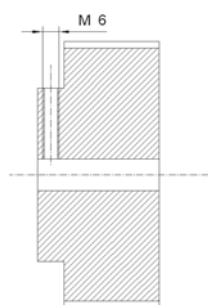

Order text for bore fastener:  
Tapped hole M6, centre of hub

### Number of flanges: 1

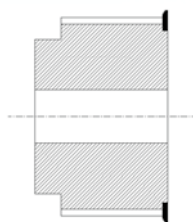

Order text for a flange  
opposite the hub side: \_\_\_\_\_-1g

### Bore fastening

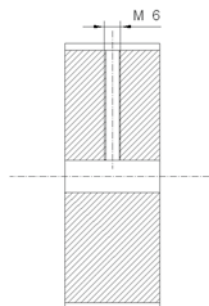

Order text for bore fastener:  
Tapped hole M6, centre of tooth gap

### Number of flanges: 1

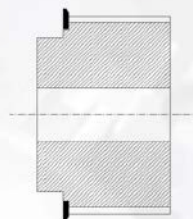

Order text for a flange  
on the hub side: \_\_\_\_\_-1a

### Further order codes:

Tapped hole M4, centre through keyway  
(or opposite keyway)

Tapped hole M4, centre through tooth gap  
(or through tooth)

Tapped hole M4, centre of hub  
90° offset to keyway

2 tapped holes M4, centre of hub  
90° and 180° offset to keyway

## Position and dimensions of turned recesses

---

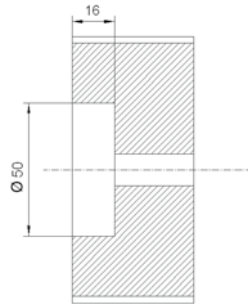

Order text for turned recess:  
Turned recess 50 x 16 deep

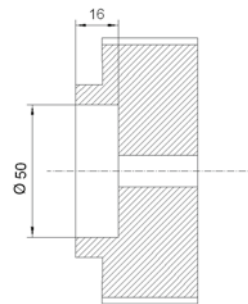

Order text for turned recess:  
Turned recess 50 x 16 deep hub side

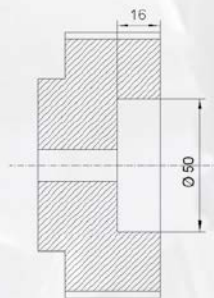

Order text for turned recess:  
Turned recess 50 x 16 deep opposite hub

# ATN system components

## Timing pulleys ATN 12.7 (ATN pulleys with 12.7 pitch only)

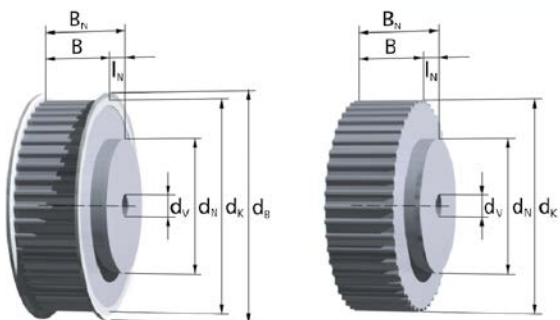

### Order example:

Pulley AL 70 ATN 12.7 / 60 - 0 Hub 110x10; dv  
 Material \_\_\_\_\_  
 Total width  $B_N$  \_\_\_\_\_  
 Type / pitch \_\_\_\_\_  
 Number of teeth \_\_\_\_\_  
 Number of flanges \_\_\_\_\_  
 Hub dimension  $d_N \times I_N$  \_\_\_\_\_

Note for part code:

dv = Diameter pre-drilled.

Refer to page 14 for further ordering information.

Belt width	b [mm]	25	50	75	100
Pulley width	B [mm]	32	60	85	110
Total width	$B_N$ [mm]	42	70	95	120

### Materials:

Sync pulley: AlCu4MgSi, RoHS-conformant  
 Flange: Galvanized steel

### Other dimensions.

- z = Number of teeth
- $d_k$  = Outside diameter
- $d_0$  = Pitch circle diameter
- $d_B$  = Flange diameter
- $d_N$  = Hub diameter
- $I_N$  = Hub length
- $d_v$  = Pre-bore diameter
- $d_{max}$  = max. bore diameter without keyway for flanged timing pulleys; no hub at maximum pre-bore

z	Hub			Bore		
	$d_k$ [mm]	$d_0$ [mm]	$d_B$ [mm]	$d_N \times I_N$ [mm]	$d_v$ [mm]	$d_{max}$ [mm]
15	58,82	60,64	67	30x10	12H7	47
16	62,86	64,68	70	32x10	12H7	51
17	66,90	68,72	74	36x10	12H7	55
18	70,95	72,77	76	40x10	12H7	59
19	74,99	76,81	82	40x10	12H7	63
20	79,03	80,85	86	46x10	12H7	67
21	83,07	84,89	90	46x10	12H7	71
22	87,12	88,94	93	46x10	12H7	75
23	91,16	92,98	96	50x10	12H7	79
24	95,20	97,02	102	58x10	12H7	83
25	99,24	101,06	105	58x10	12H7	87
26	103,29	105,11	110	58x10	12H7	91
27	107,33	109,15	113	58x10	12H7	95
28	111,37	113,19	117	60x10	12H7	99
29	115,41	117,23	121	60x10	12H7	103

z	Hub			Bore		
	$d_k$ [mm]	$d_0$ [mm]	$d_B$ [mm]	$d_N \times I_N$ [mm]	$d_v$ [mm]	$d_{max}$ [mm]
30	119,46	121,28	126	60x10	12H7	107
31	123,50	125,32	129	60x10	12H7	111
32	127,54	129,36	134	60x10	12H7	116
33	131,58	133,40	137	60x10	12H7	120
34	135,63	137,45	142	60x10	12H7	124
35	139,67	141,49	145	60x10	12H7	128
36	143,71	145,53	150	60x10	16H7	132
37	147,75	149,57	153	60x10	16H7	134
38	151,80	153,62	158	60x10	16H7	136
39	155,84	157,66	161	60x10	16H7	140
40	159,88	161,70	166	60x10	16H7	146
41	163,92	165,74	171	60x10	16H7	152
42	167,97	169,79	174	60x10	16H7	154
43	172,01	173,83	179	60x10	16H7	158
44	176,05	177,87	182	60x10	16H7	162

## Timing pulleys ATN 12.7 (ATN pulleys with 12.7 pitch only)

z	d <sub>K</sub> [mm]	d <sub>0</sub> [mm]	d <sub>B</sub> [mm]	Hub		Bore	
				d <sub>N</sub> x l <sub>N</sub> [mm]	d <sub>V</sub> [mm]	d <sub>max</sub> [mm]	
45	180,09	181,91	185	90x10	16H7	164	
46	184,14	185,96	191	90x10	16H7	170	
47	188,18	190,00	195	90x10	16H7	174	
48	192,22	194,04	198	110x10	16H7	178	
49	196,26	198,08	201	110x10	16H7	180	
<hr/>							
50	200,31	202,13	207	110x10	16H7	186	
51	204,35	206,17	210	110x10	16H7	190	
52	208,39	210,21	214	110x10	16H7	194	
53	212,43	214,25	217	110x10	16H7	196	
54	216,48	218,30	223	110x10	16H7	200	
<hr/>							
55	220,52	222,34	226	110x10	16H7	204	
56	224,56	226,38	230	110x10	16H7	208	
57	228,60	230,42	236	110x10	16H7	214	
58	232,65	234,47	239	110x10	16H7	217	
59	236,69	238,51	242	110x10	16H7	220	
<hr/>							
60	240,73	242,55	245	110x10	16H7	223	
61	244,77	246,59	252	110x10	16H7	231	
62	248,82	250,64	255	110x10	16H7	233	
63	252,86	254,68	258	110x10	16H7	236	
64	256,90	258,72	261	110x10	16H7	239	
<hr/>							
65	260,94	262,76	268	110x10	16H7	246	
66	264,99	266,81	271	110x10	16H7	249	
67	269,03	270,85	274	110x10	16H7	252	
68	273,07	274,89	280	110x10	16H7	258	
69	277,11	278,93	284	110x10	16H7	262	
<hr/>							
70	281,16	282,98	287	110x10	16H7	265	
71	285,20	287,02	290	110x10	16H7	268	
72	289,24	291,06	296	110x10	16H7	261	
73	293,28	295,11	300	140x10	20H7	265	
74	297,33	299,15	302	140x10	20H7	268	
<hr/>							
75	301,37	303,19	306	140x10	20H7	271	
76	305,41	307,23	310	140x10	20H7	274	
77	309,45	311,28	315	140x10	20H7	281	
78	313,50	315,32	320	140x10	20H7	284	
79	317,54	319,36	325	140x10	20H7	290	

z	d <sub>K</sub> [mm]	d <sub>0</sub> [mm]	d <sub>B</sub> [mm]	Hub		Bore	
				d <sub>N</sub> x l <sub>N</sub> [mm]	d <sub>V</sub> [mm]	d <sub>max</sub> [mm]	
80	321,58	323,40	329	140x10	20H7	293	
81	325,62	327,45	332	140x10	20H7	297	
82	329,67	331,49	335	140x10	20H7	300	
83	333,71	335,53	341	140x10	20H7	306	
84	337,75	339,57	344	140x10	20H7	309	
<hr/>							
85	341,79	343,62	348	140x10	20H7	312	
86	345,84	347,66	351	140x10	20H7	316	
87	349,88	351,70	355	140x10	20H7	319	
88	353,92	355,74	360	140x10	20H7	325	
89	357,96	359,79	363	140x10	20H7	328	
<hr/>							
90	362,01	363,83	367	140x10	20H7	332	
91	366,05	367,87	372	140x10	20H7	336	
92	370,09	371,91	377	140x10	20H7	341	
93	374,13	375,96	382	160x10	20H7	346	
94	378,18	380,00	386	160x10	20H7	350	
<hr/>							
95	382,22	384,04	388	160x10	20H7	350	
96	386,26	388,08	391	160x10	20H7	355	
97	390,31	392,13	396	160x10	20H7	360	
98	394,35	396,17	401	160x10	20H7	365	
99	398,39	400,21	405	160x10	20H7	369	
<hr/>							
100	402,43	404,25	410	160x10	20H7	374	
101	406,48	408,30	412	160x10	20H7	374	
102	410,52	412,34	418	160x10	20H7	379	
103	414,56	416,38	420	160x10	20H7	384	
104	418,60	420,42	425	160x10	20H7	389	
<hr/>							
105	422,65	424,47	429	160x10	20H7	393	
106	426,69	428,51	434	160x10	20H7	398	
107	430,73	432,55	438	160x10	20H7	398	
108	434,77	436,59	440	160x10	20H7	403	
109	438,82	440,64	444	160x10	20H7	408	
<hr/>							
110	442,86	444,68	448	160x10	20H7	412	
111	446,90	448,72	453	160x10	20H7	417	
112	450,94	452,76	459	160x10	20H7	422	
113	454,99	456,81	463	160x10	20H7	427	
114	459,03	460,85	465	160x10	30H7	427	



# ATN system components

## Self-tracking pulleys ATN 10 K6

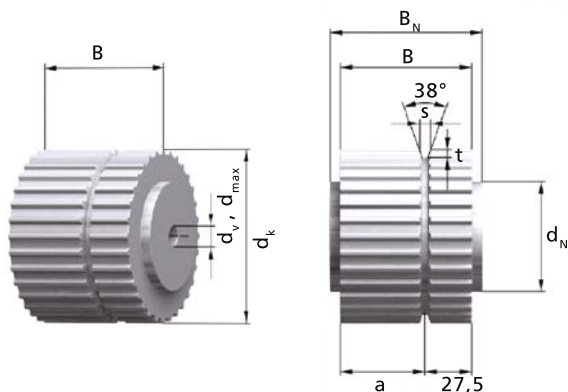

### Order example:

Pulley AL 65 ATN 10 K6 / 32 double Hub 65x5; dv  
 Material \_\_\_\_\_  
 Total width  $B_N$  \_\_\_\_\_  
 Type / pitch \_\_\_\_\_  
 Number of teeth \_\_\_\_\_  
 Bore \_\_\_\_\_

Note for part code:

dv = Diameter pre-drilled.

Refer to page 14 for further ordering information.

Belt width	b	[mm]	50	75	100
Pulley width	B	[mm]	55	80	105
Total width	$B_N$	[mm]	65	90	115
Tooth width	a	[mm]	27,5	52,5	77,5

### Material:

Pulley: AlCu4MgSi, RoHS-conformant

### Other dimensions.

- z = Number of teeth
- $d_k$  = Outside diameter
- $d_0$  = Pitch circle diameter
- s = Groove width
- t = Groove depth
- $d_N$  = Hub diameter

- $l_N$  = Hub length
- $d_v$  = Pre-bore diameter
- $d_{max}$  = max. bore diameter without keyway for flanged timing pulleys; no hub at maximum pre-bore

z	$d_k$ [mm]	$d_0$ [mm]	s [mm]	t [mm]	Hub		Bore	
					$d_N \times l_N$ [mm]	$d_v$ [mm]	$d_{max}$ [mm]	
20	61,84	63,66	6,5	5	46x5	12H7	44	
21	65,03	66,85	6,5	5	46x5	12H7	47	
22	68,21	70,03	6,5	5	50x5	12H7	51	
23	71,39	73,21	6,5	5	50x5	12H7	53	
24	74,57	76,39	6,5	5	58x5	12H7	56	
25	77,76	79,58	6,5	5	60x5	12H7	59	
26	80,94	82,76	6,5	5	60x5	12H7	62	
27	84,12	85,94	6,5	5	60x5	12H7	66	
28	87,31	89,13	6,5	5	60x5	12H7	69	
29	90,49	92,31	6,5	5	60x5	12H7	72	

z	$d_k$ [mm]	$d_0$ [mm]	s [mm]	t [mm]	Hub		Bore	
					$d_N \times l_N$ [mm]	$d_v$ [mm]	$d_{max}$ [mm]	
30	93,67	95,49	6,5	5	60x5	12H7	75	
31	96,86	98,68	6,5	5	60x5	12H7	78	
32	100,04	101,86	6,5	5	65x5	12H7	82	
33	103,22	105,04	6,5	5	65x5	12H7	85	
34	106,41	108,23	6,5	5	65x5	12H7	88	
35	109,59	111,41	6,5	5	65x5	12H7	91	
36	112,77	114,59	6,5	5	70x5	16H7	94	
37	115,95	117,77	6,5	5	70x5	16H7	98	
38	119,14	120,96	6,5	5	70x5	16H7	101	
39	122,32	124,14	6,5	5	70x5	16H7	104	
40	125,50	127,32	6,5	5	80x5	16H7	109	
41	128,69	130,51	6,5	5	80x5	16H7	112	
42	131,87	133,69	6,5	5	80x5	16H7	115	
43	135,05	136,87	6,5	5	80x5	16H7	118	
44	138,24	140,06	6,5	5	90x5	16H7	122	

## Self-tracking pulleys ATN 10 K6

z	d <sub>K</sub> [mm]	d <sub>0</sub> [mm]	s [mm]	t [mm]	Hub		Bore	
					d <sub>N</sub> × l <sub>N</sub> [mm]	d <sub>V</sub> [mm]	d <sub>max</sub> [mm]	
45	141,42	143,24	6,5	5	90x5	16H7	123	
46	144,60	146,42	6,5	5	90x5	16H7	126	
47	147,79	149,61	6,5	5	90x5	16H7	129	
48	150,97	152,79	6,5	5	95x5	16H7	132	
49	154,15	155,97	6,5	5	95x5	16H7	136	
50	157,33	159,15	6,5	5	95x5	16H7	139	
51	160,52	162,34	6,5	5	95x5	16H7	142	
52	163,70	165,52	6,5	5	110x5	16H7	145	
53	166,88	168,70	6,5	5	110x5	16H7	148	
54	170,07	171,89	6,5	5	110x5	16H7	152	
55	173,25	175,07	6,5	5	110x5	16H7	155	
56	176,43	178,25	6,5	5	110x5	16H7	158	
57	179,62	181,44	6,5	5	110x5	16H7	161	
58	182,80	184,62	6,5	5	110x5	16H7	164	
59	185,98	187,80	6,5	5	110x5	16H7	167	
60	189,17	190,99	6,5	5	110x5	16H7	171	
61	192,35	194,17	6,5	5	110x5	16H7	174	
62	195,53	197,35	6,5	5	110x5	16H7	177	
63	198,72	200,54	6,5	5	140x5	16H7	181	
64	201,90	203,72	6,5	5	140x5	16H7	183	
65	205,08	206,90	6,5	5	140x5	16H7	187	
66	208,26	210,08	6,5	5	140x5	16H7	190	
67	211,45	213,27	6,5	5	140x5	16H7	193	
68	214,63	216,45	6,5	5	140x5	16H7	196	
69	217,81	219,63	6,5	5	140x5	16H7	201	
70	221,00	222,82	6,5	5	140x5	16H7	203	
71	224,18	226,00	6,5	5	140x5	16H7	206	
72	227,36	229,18	6,5	5	140x5	20H7	209	
73	230,55	232,37	6,5	5	140x5	20H7	212	
74	233,73	235,55	6,5	5	140x5	20H7	215	
75	236,91	238,73	6,5	5	140x5	20H7	218	
76	240,10	241,92	6,5	5	140x5	20H7	222	
77	243,28	245,10	6,5	5	160x5	20H7	225	
78	246,46	248,28	6,5	5	160x5	20H7	228	
79	249,64	251,46	6,5	5	160x5	20H7	232	

z	d <sub>K</sub> [mm]	d <sub>0</sub> [mm]	s [mm]	t [mm]	Hub		Bore	
					d <sub>N</sub> × l <sub>N</sub> [mm]	d <sub>V</sub> [mm]	d <sub>max</sub> [mm]	
80	252,83	254,65	6,5	5	160x5	20H7	234	
81	256,01	257,83	6,5	5	160x5	20H7	238	
82	259,19	261,01	6,5	5	160x5	20H7	241	
83	262,38	264,20	6,5	5	160x5	20H7	244	
84	265,56	267,38	6,5	5	160x5	20H7	247	
85	268,74	270,56	6,5	5	160x5	20H7	250	
86	271,93	273,75	6,5	5	160x5	20H7	253	
87	275,11	276,93	6,5	5	160x5	20H7	257	
88	278,29	280,11	6,5	5	160x5	20H7	260	
89	281,48	283,30	6,5	5	160x5	20H7	263	
90	284,66	286,48	6,5	5	160x5	20H7	268	
91	287,84	289,66	6,5	5	160x5	20H7	270	
92	291,03	292,85	6,5	5	160x5	20H7	273	
93	294,21	296,03	6,5	5	160x5	20H7	276	
94	297,39	299,21	6,5	5	160x5	20H7	279	
95	300,57	302,39	6,5	5	160x5	24H7	282	
96	303,76	305,58	6,5	5	180x5	24H7	285	
97	306,94	308,76	6,5	5	180x5	24H7	288	
98	310,12	311,94	6,5	5	180x5	24H7	292	
99	313,31	315,13	6,5	5	180x5	24H7	295	
100	316,49	318,31	6,5	5	180x5	24H7	298	
101	319,67	321,49	6,5	5	180x5	24H7	301	
102	322,86	324,68	6,5	5	180x5	24H7	304	
103	326,04	327,86	6,5	5	180x5	24H7	308	
104	329,22	331,04	6,5	5	180x5	24H7	311	
105	332,41	334,23	6,5	5	180x5	24H7	314	
106	335,59	337,41	6,5	5	180x5	24H7	317	
107	338,77	340,59	6,5	5	180x5	24H7	321	
108	341,95	343,77	6,5	5	180x5	24H7	324	
109	345,14	346,96	6,5	5	180x5	24H7	327	
110	348,32	350,14	6,5	5	180x5	24H7	330	
111	351,50	353,32	6,5	5	180x5	24H7	333	
112	354,69	356,51	6,5	5	180x5	24H7	336	
113	357,87	359,69	6,5	5	180x5	24H7	339	
114	361,05	362,87	6,5	5	180x5	24H7	343	

# ATN system components

## Self-tracking pulleys ATN 12.7 K6

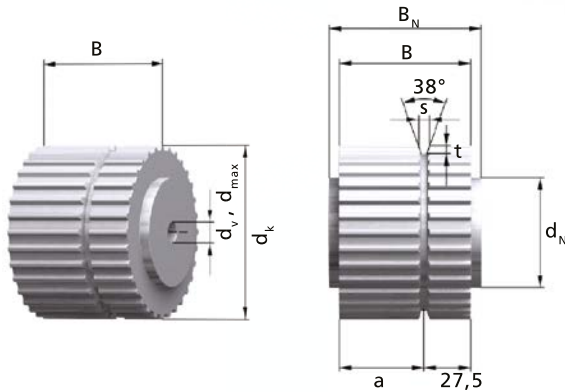

**Order example:**

Pulley AL 65 ATN 12.7 K6 / 32 double Hub 60x5; dv  
 Material  
 Total width B<sub>N</sub>  
 Type / pitch  
 Number of teeth  
 Bore

Note for part code:  
 dv = Diameter pre-drilled.  
 Refer to page 14 for further ordering information.

Belt width	b [mm]	50	75	100
Pulley width	B [mm]	55	80	105
Total width	B <sub>N</sub> [mm]	65	90	115
Tooth width	a [mm]	27,5	52,5	77,5

**Material:**  
 Pulley: AlCu4MgSi, RoHS-conformant

**Other dimensions.**

- z = Number of teeth
- d<sub>k</sub> = Outside diameter
- d<sub>0</sub> = Pitch circle diameter
- s = Groove width
- t = Groove depth
- d<sub>N</sub> = Hub diameter

- l<sub>N</sub> = Hub length
- d<sub>v</sub> = Pre-bore diameter
- d<sub>max</sub> = max. bore diameter without keyway for flanged timing pulleys; no hub at maximum pre-bore

z	d <sub>k</sub> [mm]	d <sub>0</sub> [mm]	s [mm]	t [mm]	Hub		Bore	
					d <sub>N</sub> x l <sub>N</sub> [mm]	d <sub>v</sub> d <sub>max</sub> [mm] [mm]		
20	79,03	80,85	6,5	5	46x5	12H7	59	
21	83,07	84,89	6,5	5	46x5	12H7	63	
22	87,12	88,94	6,5	5	46x5	12H7	67	
23	91,16	92,98	6,5	5	50x5	12H7	71	
24	95,20	97,02	6,5	5	58x5	12H7	75	
25	99,24	101,06	6,5	5	58x5	12H7	79	
26	103,29	105,11	6,5	5	58x5	12H7	83	
27	107,33	109,15	6,5	5	58x5	12H7	87	
28	111,37	113,19	6,5	5	60x5	12H7	91	
29	115,41	117,23	6,5	5	60x5	12H7	95	

z	d <sub>k</sub> [mm]	d <sub>0</sub> [mm]	s [mm]	t [mm]	Hub		Bore	
					d <sub>N</sub> x l <sub>N</sub> [mm]	d <sub>v</sub> d <sub>max</sub> [mm] [mm]		
30	119,46	121,28	6,5	5	60x5	12H7	99	
31	123,50	125,32	6,5	5	60x5	12H7	104	
32	127,54	129,36	6,5	5	60x5	12H7	108	
33	131,58	133,40	6,5	5	60x5	12H7	112	
34	135,63	137,45	6,5	5	60x5	12H7	116	
35	139,67	141,49	6,5	5	60x5	12H7	120	
36	143,71	145,53	6,5	5	60x5	16H7	124	
37	147,75	149,57	6,5	5	60x5	16H7	128	
38	151,80	153,62	6,5	5	60x5	16H7	132	
39	155,84	157,66	6,5	5	60x5	16H7	136	
40	159,88	161,70	6,5	5	60x5	16H7	140	
41	163,92	165,74	6,5	5	60x5	16H7	144	
42	167,97	169,79	6,5	5	60x5	16H7	148	
43	172,01	173,83	6,5	5	60x5	16H7	152	
44	176,05	177,87	6,5	5	60x5	16H7	156	

## Self-tracking pulleys ATN 12.7 K6

z	d <sub>K</sub> [mm]	d <sub>0</sub> [mm]	s [mm]	t [mm]	Hub		Bore	
					d <sub>N</sub> x l <sub>N</sub> [mm]	d <sub>V</sub> [mm]	d <sub>max</sub> [mm]	
45	180,09	181,91	6,5	5	90x5	16H7	160	
46	184,14	185,96	6,5	5	90x5	16H7	164	
47	188,18	190,00	6,5	5	90x5	16H7	168	
48	192,22	194,04	6,5	5	110x5	16H7	172	
49	196,26	198,08	6,5	5	110x5	16H7	176	
50	200,31	202,13	6,5	5	110x5	16H7	180	
51	204,35	206,17	6,5	5	110x5	16H7	184	
52	208,39	210,21	6,5	5	110x5	16H7	188	
53	212,43	214,25	6,5	5	110x5	16H7	192	
54	216,48	218,30	6,5	5	110x5	16H7	196	
55	220,52	222,34	6,5	5	110x5	16H7	201	
56	224,56	226,38	6,5	5	110x5	16H7	205	
57	228,60	230,42	6,5	5	110x5	16H7	209	
58	232,65	234,47	6,5	5	110x5	16H7	213	
59	236,69	238,51	6,5	5	110x5	16H7	217	
60	240,73	242,55	6,5	5	110x5	16H7	221	
61	244,77	246,59	6,5	5	110x5	16H7	225	
62	248,82	250,64	6,5	5	110x5	16H7	229	
63	252,86	254,68	6,5	5	110x5	16H7	233	
64	256,90	258,72	6,5	5	110x5	16H7	237	
65	260,94	262,76	6,5	5	110x5	16H7	241	
66	264,99	266,81	6,5	5	110x5	16H7	245	
67	269,03	270,85	6,5	5	110x5	16H7	249	
68	273,07	274,89	6,5	5	110x5	16H7	253	
69	277,11	278,93	6,5	5	110x5	16H7	257	
70	281,16	282,98	6,5	5	110x5	16H7	261	
71	285,20	287,02	6,5	5	110x5	16H7	265	
72	289,24	291,06	6,5	5	110x5	16H7	269	
73	293,28	295,11	6,5	5	140x5	20H7	273	
74	297,33	299,15	6,5	5	140x5	20H7	277	
75	301,37	303,19	6,5	5	140x5	20H7	281	
76	305,41	307,23	6,5	5	140x5	20H7	285	
77	309,45	311,28	6,5	5	140x5	20H7	289	
78	313,50	315,32	6,5	5	140x5	20H7	294	
79	317,54	319,36	6,5	5	140x5	20H7	298	

z	d <sub>K</sub> [mm]	d <sub>0</sub> [mm]	s [mm]	t [mm]	Hub		Bore	
					d <sub>N</sub> x l <sub>N</sub> [mm]	d <sub>V</sub> [mm]	d <sub>max</sub> [mm]	
80	321,58	323,40	6,5	5	140x5	20H7	302	
81	325,62	327,45	6,5	5	140x5	20H7	306	
82	329,67	331,49	6,5	5	140x5	20H7	310	
83	333,71	335,53	6,5	5	140x5	20H7	314	
84	337,75	339,57	6,5	5	140x5	20H7	318	
85	341,79	343,62	6,5	5	140x5	20H7	322	
86	345,84	347,66	6,5	5	140x5	20H7	326	
87	349,88	351,70	6,5	5	140x5	20H7	330	
88	353,92	355,74	6,5	5	140x5	20H7	334	
89	357,96	359,79	6,5	5	140x5	20H7	338	
90	362,01	363,83	6,5	5	140x5	20H7	342	
91	366,05	367,87	6,5	5	140x5	20H7	346	
92	370,09	371,91	6,5	5	140x5	20H7	350	
93	374,13	375,96	6,5	5	160x5	20H7	354	
94	378,18	380,00	6,5	5	160x5	20H7	358	
95	382,22	384,04	6,5	5	160x5	20H7	362	
96	386,26	388,08	6,5	5	160x5	20H7	366	
97	390,31	392,13	6,5	5	160x5	20H7	370	
98	394,35	396,17	6,5	5	160x5	20H7	374	
99	398,39	400,21	6,5	5	160x5	20H7	378	
100	402,43	404,25	6,5	5	160x5	20H7	382	
101	406,48	408,30	6,5	5	160x5	20H7	386	
102	410,52	412,34	6,5	5	160x5	20H7	391	
103	414,56	416,38	6,5	5	160x5	20H7	395	
104	418,60	420,42	6,5	5	160x5	20H7	399	
105	422,65	424,47	6,5	5	160x5	20H7	403	
106	426,69	428,51	6,5	5	160x5	20H7	407	
107	430,73	432,55	6,5	5	160x5	20H7	411	
108	434,77	436,59	6,5	5	160x5	20H7	415	
109	438,82	440,64	6,5	5	160x5	20H7	419	
110	442,86	444,68	6,5	5	160x5	20H7	423	
111	446,90	448,72	6,5	5	160x5	20H7	427	
112	450,94	452,76	6,5	5	160x5	20H7	431	
113	454,99	456,81	6,5	5	160x5	20H7	435	
114	459,03	460,85	6,5	5	160x5	30H7	439	

# Timing pulleys AT-Profile

## AT 3

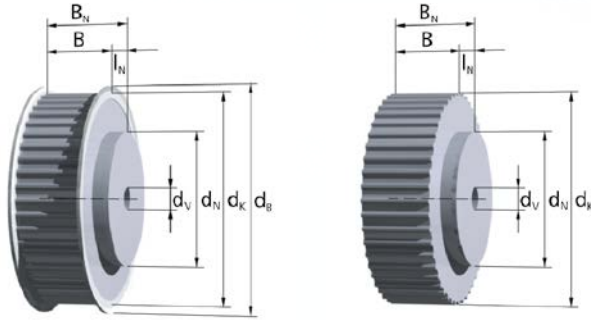

Stock pulleys up to  $z = 40$  with flanges

Stock pulleys over  $z = 44$  without flanges

### Order example:

Timing pulley AL 28 AT 3 / 60 - 0 Hub 38x6; dv  
 Material  
 Total width  $B_N$   
 Type / pitch  
 Number of teeth  
 Number of flanges  
 Hub dimension  $d_N \times l_N$

Note for part code:

dv = Diameter pre-drilled.

Refer to page 14 for further ordering information.

Belt width	b [mm]	6	10	16	25	32
Pulley width	B [mm]	10	15	22	32	40
Total width	$B_N$ [mm]	16	21	28	38	46

### Materials:

Pulley: AlCu4MgSi, RoHS-conformant  
 Flange: Galvanized steel

The stock pulleys with standard dimensioning are marked in blue.

In-between widths and larger widths as well as other hub dimensions are available.

- $z$  = Number of teeth
- $d_k$  = Outside diameter
- $d_0$  = Pitch circle diameter
- $d_B$  = Flange diameter
- $d_N$  = Hub diameter

- $l_N$  = Hub length
- $d_v$  = Pre-bore diameter
- $d_{max}$  = max. bore diameter without keyway for flanged timing pulleys; no hub at maximum pre-bore

z	Hub			Bore		
	$d_k$ [mm]	$d_0$ [mm]	$d_B$ [mm]	$d_N \times l_N$ [mm]	$d_v$ [mm]	$d_{max}$ [mm]
15	13,91	14,32	17	10x6	4H7	4
16	14,87	15,28	18	10x6	4H7	5
17	15,82	16,23	19	10x6	4H7	6
18	16,78	17,19	21	12x6	4H7	7
19	17,73	18,14	23	12x6	4H7	8
20	18,69	19,10	24	14x6	4H7	9
21	19,64	20,05	25	14x6	6H7	10
22	20,60	21,01	26	14x6	6H7	11
23	21,55	21,96	26	14x6	6H7	12
24	22,51	22,92	28	14x6	6H7	13
25	23,46	23,87	30	16x6	6H7	14
26	24,42	24,83	30	16x6	6H7	15
27	25,37	25,78	30	16x6	6H7	15
28	26,33	26,74	32	16x6	6H7	16
29	27,28	27,69	34	16x6	6H7	17

z	Hub			Bore		
	$d_k$ [mm]	$d_0$ [mm]	$d_B$ [mm]	$d_N \times l_N$ [mm]	$d_v$ [mm]	$d_{max}$ [mm]
30	28,24	28,65	34	20x6	6H7	18
31	29,19	29,60	35	20x6	6H7	19
32	30,15	30,56	36	20x6	6H7	20
33	31,10	31,51	36	20x6	6H7	21
34	32,06	32,47	37	20x6	6H7	22
35	33,01	33,42	39	20x6	6H7	23
36	33,97	34,38	40	22x6	6H7	24
37	34,92	35,33	40	22x6	6H7	25
38	35,88	36,29	42	22x6	6H7	26
39	36,83	37,24	42	22x6	6H7	27
40	37,79	38,20	43	26x6	6H7	28
41	38,74	39,15	45	26x6	6H7	29
42	39,70	40,11	45	26x6	6H7	30
43	40,65	41,06	47	26x6	6H7	31
44	41,61	42,02	47	30x6	6H7	32



## AT 3

z	Hub			Bore		
	d <sub>K</sub> [mm]	d <sub>0</sub> [mm]	d <sub>B</sub> [mm]	d <sub>N</sub> x l <sub>N</sub> [mm]	d <sub>V</sub> [mm]	d <sub>max</sub> [mm]
45	42,56	42,97	48	30x6	6H7	33
46	43,52	43,93	50	30x6	6H7	34
47	44,47	44,88	50	30x6	6H7	35
48	45,43	45,84	52	34x6	6H7	36
49	46,38	46,79	52	34x6	6H7	36
50	47,34	47,75	53	34x6	6H7	37
51	48,29	48,70	53	34x6	6H7	38
52	49,25	49,66	55	34x6	6H7	39
53	50,20	50,61	55	34x6	6H7	40
54	51,16	51,57	56	34x6	6H7	41
55	52,11	52,52	58	34x6	6H7	42
56	53,07	53,48	58	34x6	6H7	43
57	54,02	54,43	60	34x6	6H7	44
58	54,98	55,39	60	34x6	6H7	45
59	55,93	56,34	61	34x6	6H7	46
60	56,89	57,30	62	38x6	6H7	47
61	57,84	58,25	64	38x6	6H7	48
62	58,80	59,21	64	38x6	6H7	49
63	59,75	60,16	66	38x6	6H7	50
64	60,71	61,12	66	38x6	6H7	51
65	61,66	62,07	68	38x6	6H7	52
66	62,62	63,03	68	38x6	6H7	53
67	63,57	63,98	70	38x6	6H7	54
68	64,53	64,94	70	38x6	6H7	55
69	65,48	65,89	72	38x6	6H7	56
70	66,44	66,85	72	38x6	6H7	57
71	67,39	67,80	74	38x6	6H7	58
72	68,34	68,75	74	50x6	6H7	58
73	69,30	69,71	74	50x6	8H7	59
74	70,25	70,66	75	50x6	8H7	60
75	71,21	71,62	76	50x6	8H7	61
76	72,16	72,57	78	50x6	8H7	62
77	73,12	73,53	78	50x6	8H7	63
78	74,07	74,48	80	50x6	8H7	64
79	75,03	75,44	80	50x6	8H7	65

z	Hub			Bore		
	d <sub>K</sub> [mm]	d <sub>0</sub> [mm]	d <sub>B</sub> [mm]	d <sub>N</sub> x l <sub>N</sub> [mm]	d <sub>V</sub> [mm]	d <sub>max</sub> [mm]
80	75,98	76,39	82	50x6	8H7	66
81	76,94	77,35	82	50x6	8H7	67
82	77,89	78,30	84	50x6	8H7	68
83	78,85	79,26	84	50x6	8H7	69
84	79,80	80,21	86	50x6	8H7	70
85	80,76	81,17	86	50x6	8H7	71
86	81,71	82,12	88	50x6	8H7	72
87	82,67	83,08	88	50x6	8H7	73
88	83,62	84,03	90	50x6	8H7	74
89	84,58	84,99	90	50x6	8H7	75
90	85,53	85,94	91	50x6	8H7	76
91	86,49	86,90	93	65x6	8H7	77
92	87,44	87,85	93	65x6	8H7	78
93	88,40	88,81	94	65x6	8H7	79
94	89,35	89,76	94	65x6	8H7	79
95	90,31	90,72	96	65x6	8H7	80
96	91,26	91,67	96	65x6	8H7	81
97	92,22	92,63	96	65x6	8H7	82
98	93,17	93,58	99	65x6	8H7	83
99	94,13	94,54	99	65x6	8H7	84
100	95,08	95,49	100	65x6	8H7	85
101	96,04	96,45	100	65x6	8H7	86
102	96,99	97,40	102	65x6	8H7	87
103	97,95	98,36	102	65x6	8H7	88
104	98,90	99,31	104	65x6	8H7	89
105	99,86	100,27	104	65x6	8H7	90
106	100,81	101,22	104	65x6	10H7	91
107	101,77	102,18	106	65x6	10H7	92
108	102,72	103,13	106	65x6	10H7	93
109	103,68	104,09	108	65x6	10H7	94
110	104,63	105,04	108	65x6	10H7	95
111	105,59	106,00	110	65x6	10H7	96
112	106,54	106,95	110	65x6	10H7	97
113	107,50	107,91	112	65x6	10H7	98
114	108,45	108,86	112	65x6	10H7	99

# Timing pulleys AT-Profile

## AT 5

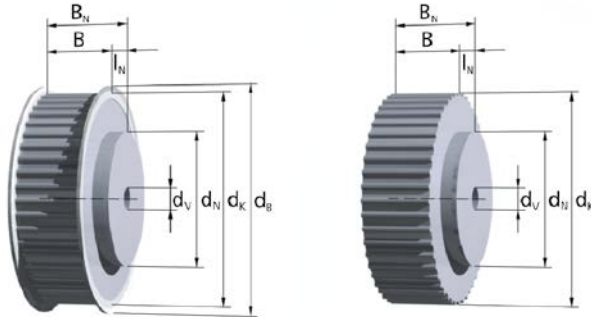

Stock pulleys up to  $z = 44$  with flanges

Stock pulleys over  $z = 48$  without flanges

### Order example:

Pulley AL 28 AT 5 / 60 - 0 Hub 65x6; dv  
 Material \_\_\_\_\_  
 Total width  $B_N$  \_\_\_\_\_  
 Type / pitch \_\_\_\_\_  
 Number of teeth \_\_\_\_\_  
 Number of flanges \_\_\_\_\_  
 Hub dimension  $d_N \times l_N$  \_\_\_\_\_

Note for part code:

dv = Diameter pre-drilled.

Refer to page 14 for further ordering information.

Belt width	b	[mm]	10	16	25	32	50	75	100
Pulley width	B	[mm]	16	22	32	40	60	85	110
Total width	$B_N$	[mm]	22	28	38	46	66	90	115

### Materials:

Pulley: AlCu4MgSi, RoHS-conformant  
 Flange: Galvanized steel

The stock pulleys with standard dimensioning are marked in blue.

In-between widths and larger widths as well as other hub dimensions are available.

- $z$  = Number of teeth
- $d_k$  = Outside diameter
- $d_0$  = Pitch circle diameter
- $d_B$  = Flange diameter
- $d_N$  = Hub diameter

- $l_N$  = Hub length
- $d_v$  = Pre-bore diameter
- $d_{max}$  = max. bore diameter without keyway for flanged timing pulleys; no hub at maximum pre-bore

z	Hub			Bore		
	$d_k$ [mm]	$d_0$ [mm]	$d_B$ [mm]	$d_N \times l_N$ [mm]	$d_v$ [mm]	$d_{max}$ [mm]
15	22,65	23,87	28	16x6	6H7	10
16	24,24	25,46	30	18x6	6H7	12
17	25,84	27,06	32	18x6	6H7	14
18	27,43	28,65	34	20x6	6H7	16
19	29,02	30,24	35	22x6	6H7	16
20	30,61	31,83	36	24x6	6H7	18
21	32,20	33,42	37	24x6	6H7	20
22	33,79	35,01	39	24x6	6H7	22
23	35,39	36,61	40	24x6	8H7	24
24	36,98	38,20	42	26x6	8H7	24
25	38,57	39,79	43	26x6	8H7	25
26	40,16	41,38	45	26x6	8H7	25
27	41,75	42,97	47	30x6	8H7	27
28	43,34	44,56	48	30x6	8H7	29
29	44,93	46,15	50	30x6	8H7	31

z	Hub			Bore		
	$d_k$ [mm]	$d_0$ [mm]	$d_B$ [mm]	$d_N \times l_N$ [mm]	$d_v$ [mm]	$d_{max}$ [mm]
30	46,53	47,75	52	34x6	8H7	33
31	48,12	49,34	53	34x6	8H7	35
32	49,71	50,93	55	38x6	8H7	37
33	51,30	52,52	56	38x6	8H7	39
34	52,89	54,11	58	38x6	8H7	39
35	54,48	55,70	60	38x6	8H7	40
36	56,08	57,30	61	38x6	8H7	42
37	57,67	58,89	62	38x6	8H7	43
38	59,26	60,48	64	38x6	8H7	45
39	60,85	62,07	66	38x6	8H7	45
40	62,44	63,66	68	40x6	8H7	47
41	64,03	65,25	70	40x6	8H7	48
42	65,63	66,85	72	40x6	8H7	50
43	67,22	68,44	72	40x6	8H7	52
44	68,81	70,03	74	50x6	8H7	52

## AT 5

z	d <sub>K</sub> [mm]	d <sub>0</sub> [mm]	d <sub>B</sub> [mm]	Hub		Bore	
				d <sub>N</sub> x l <sub>N</sub> [mm]	d <sub>V</sub> [mm]	d <sub>max</sub> [mm]	
45	70,40	71,62	75	50x6	8H7	54	
46	71,99	73,21	76	50x6	8H7	56	
47	73,58	74,80	78	50x6	8H7	58	
48	75,17	76,39	80	50x6	8H7	60	
49	76,77	77,99	82	50x6	8H7	60	
50	78,36	79,58	84	50x6	8H7	60	
51	79,95	81,17	86	50x6	8H7	62	
52	81,54	82,76	86	50x6	8H7	64	
53	83,13	84,35	88	50x6	8H7	66	
54	84,72	85,94	90	50x6	8H7	66	
55	86,32	87,54	91	50x6	8H7	68	
56	87,91	89,13	93	50x6	8H7	70	
57	89,50	90,72	94	50x6	8H7	72	
58	91,09	92,31	96	50x6	8H7	74	
59	92,68	93,90	99	50x6	8H7	74	
60	94,27	95,49	99	65x6	8H7	76	
61	95,86	97,08	100	65x6	8H7	79	
62	97,46	98,68	102	65x6	8H7	80	
63	99,05	100,27	104	65x6	8H7	82	
64	100,64	101,86	105	65x6	8H7	82	
65	102,23	103,45	107	65x6	8H7	84	
66	103,82	105,04	109	65x6	8H7	86	
67	105,41	106,63	112	65x6	8H7	88	
68	107,01	108,23	112	65x6	8H7	90	
69	108,60	109,82	115	65x6	8H7	90	
70	110,19	111,41	115	65x6	8H7	90	
71	111,78	113,00	117	65x6	8H7	92	
72	113,37	114,59	118	80x6	8H7	94	
73	114,96	116,18	121	80x6	10H7	96	
74	116,55	117,77	121	80x6	10H7	96	
75	118,15	119,37	123	80x6	10H7	98	
76	119,74	120,96	125	80x6	10H7	100	
77	121,33	122,55	128	80x6	10H7	102	
78	122,92	124,14	128	80x6	10H7	104	
79	124,51	125,73	131	80x6	10H7	104	

z	d <sub>K</sub> [mm]	d <sub>0</sub> [mm]	d <sub>B</sub> [mm]	Hub		Bore	
				d <sub>N</sub> x l <sub>N</sub> [mm]	d <sub>V</sub> [mm]	d <sub>max</sub> [mm]	
80	126,10	127,32	131	80x6	10H7	106	
81	127,70	128,92	134	80x6	10H7	108	
82	129,29	130,51	134	80x6	10H7	110	
83	130,88	132,10	137	80x6	10H7	110	
84	132,47	133,69	137	80x6	10H7	112	
85	134,06	135,28	140	80x6	10H7	114	
86	135,65	136,87	142	80x6	10H7	116	
87	137,24	138,46	142	80x6	10H7	119	
88	138,84	140,06	144	80x6	10H7	119	
89	140,43	141,65	147	80x6	10H7	120	
90	142,02	143,24	147	80x6	10H7	120	
91	143,61	144,83	150	90x6	10H7	122	
92	145,20	146,42	150	90x6	10H7	124	
93	146,79	148,01	153	90x6	10H7	126	
94	148,39	149,61	153	90x6	10H7	126	
95	149,98	151,20	156	90x6	10H7	129	
96	151,57	152,79	156	90x6	10H7	130	
97	153,16	154,38	158	90x6	10H7	130	
98	154,75	155,97	160	90x6	10H7	132	
99	156,34	157,56	163	90x6	10H7	132	
100	157,93	159,15	163	90x6	10H7	134	
101	159,53	160,75	166	95x6	12H7	136	
102	161,12	162,34	166	95x6	12H7	139	
103	162,71	163,93	169	95x6	12H7	140	
104	164,30	165,52	169	95x6	12H7	140	
105	165,89	167,11	171	95x6	12H7	140	
106	167,48	168,70	172	95x6	12H7	142	
107	169,08	170,30	174	95x6	12H7	146	
108	170,67	171,89	176	95x6	12H7	146	
109	172,26	173,48	179	110x6	12H7	148	
110	173,85	175,07	179	110x6	12H7	150	
111	175,44	176,66	180	110x6	12H7	150	
112	177,03	178,25	182	110x6	12H7	152	
113	178,63	179,85	185	110x6	12H7	152	
114	180,22	181,44	185	110x6	12H7	152	

# Timing pulleys AT-Profile

## AT 10 (Also for ATN 10-toothed belt)

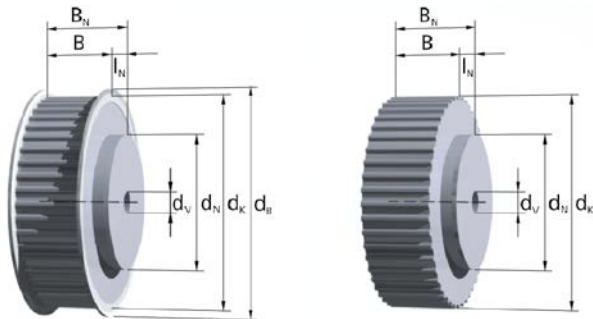

Stock pulleys up to  $z = 44$  with flanges

Stock pulleys over  $z = 48$  without flanges

### Order example:

Pulley AL 70 AT 10 / 60 - 0 Hub 110x10; dv  
 Material \_\_\_\_\_  
 Total width  $B_N$  \_\_\_\_\_  
 Type / pitch \_\_\_\_\_  
 Number of teeth \_\_\_\_\_  
 Number of flanges \_\_\_\_\_  
 Hub dimension  $d_N \times l_N$  \_\_\_\_\_

Note for part code:

$d_v$  = Diameter pre-drilled.

Refer to page 14 for further ordering information.

Belt width	b [mm]	16	25	32	50	75	100	150
Pulley width	B [mm]	23	32	40	60	85	110	160
Width für ATN-System	B [mm]	-	32	-	60	85	110	-
Total width	$B_N$ [mm]	33	42	50	70	95	120	170

### Materials:

Pulley: AlCu4MgSi, RoHS-conformant  
 Flange: Galvanized steel

The stock pulleys with standard dimensioning are marked in blue.

In-between widths and larger widths as well as other hub dimensions are available.

- $z$  = Number of teeth
- $d_k$  = Outside diameter
- $d_o$  = Pitch circle diameter
- $d_B$  = Flange diameter
- $d_N$  = Hub diameter

- $l_N$  = Hub length
- $d_v$  = Pre-bore diameter
- $d_{max}$  = max. bore diameter without keyway for flanged timing pulleys; no hub at maximum pre-bore

z	Hub			Bore		
	$d_k$ [mm]	$d_o$ [mm]	$d_B$ [mm]	$d_N \times l_N$ [mm]	$d_v$ [mm]	$d_{max}$ [mm]
15	45,93	47,75	52	32x10	8H7	34
16	49,11	50,93	55	35x10	8H7	36
17	52,29	54,11	58	40x10	8H7	40
18	55,48	57,30	61	40x10	8H7	44
19	58,66	60,48	64	44x10	8H7	46
20	61,84	63,66	68	46x10	12H7	50
21	65,03	66,85	72	46x10	12H7	52
22	68,21	70,03	74	50x10	12H7	56
23	71,39	73,21	76	50x10	12H7	60
24	74,57	76,39	80	58x10	12H7	62
25	77,76	79,58	84	60x10	12H7	66
26	80,94	82,76	86	60x10	12H7	68
27	84,12	85,94	90	60x10	12H7	72
28	87,31	89,13	93	60x10	12H7	76
29	90,49	92,31	96	60x10	12H7	78

z	Hub			Bore		
	$d_k$ [mm]	$d_o$ [mm]	$d_B$ [mm]	$d_N \times l_N$ [mm]	$d_v$ [mm]	$d_{max}$ [mm]
30	93,67	95,49	99	60x10	12H7	82
31	96,86	98,68	102	60x10	12H7	84
32	100,04	101,86	106	65x10	12H7	88
33	103,22	105,04	109	65x10	12H7	88
34	106,41	108,23	112	65x10	12H7	92
35	109,59	111,41	115	65x10	12H7	96
36	112,77	114,59	118	70x10	16H7	98
37	115,95	117,77	121	70x10	16H7	101
38	119,14	120,96	125	70x10	16H7	104
39	122,32	124,14	128	70x10	16H7	106
40	125,50	127,32	131	80x10	16H7	110
41	128,69	130,51	134	80x10	16H7	110
42	131,87	133,69	137	80x10	16H7	112
43	135,05	136,87	140	80x10	16H7	114
44	138,24	140,06	144	90x10	16H7	118



# AT 10 (Also for ATN 10-toothed belt)

z	Hub			Bore		
	d <sub>K</sub> [mm]	d <sub>0</sub> [mm]	d <sub>B</sub> [mm]	d <sub>N</sub> x l <sub>N</sub> [mm]	d <sub>V</sub> [mm]	d <sub>max</sub> [mm]
45	141,42	143,24	147	90x10	16H7	120
46	144,60	146,42	150	90x10	16H7	122
47	147,79	149,61	153	90x10	16H7	122
48	150,97	152,79	156	95x10	16H7	124
49	154,15	155,97	160	95x10	16H7	126
50	157,33	159,15	163	95x10	16H7	130
51	160,52	162,34	166	95x10	16H7	134
52	163,70	165,52	169	110x10	16H7	136
53	166,88	168,70	172	110x10	16H7	140
54	170,07	171,89	176	110x10	16H7	144
55	173,25	175,07	179	110x10	16H7	146
56	176,43	178,25	182	110x10	16H7	150
57	179,62	181,44	185	110x10	16H7	152
58	182,80	184,62	188	110x10	16H7	156
59	185,98	187,80	191	110x10	16H7	160
60	189,17	190,99	195	110x10	16H7	162
61	192,35	194,17	198	110x10	16H7	164
62	195,53	197,35	201	110x10	16H7	166
63	198,72	200,54	204	140x10	16H7	170
64	201,90	203,72	207	140x10	16H7	171
65	205,08	206,90	210	140x10	16H7	174
66	208,26	210,08	214	140x10	16H7	175
67	211,45	213,27	217	140x10	16H7	177
68	214,63	216,45	220	140x10	16H7	181
69	217,81	219,63	223	140x10	16H7	185
70	221,00	222,82	226	140x10	16H7	187
71	224,18	226,00	230	140x10	16H7	191
72	227,36	229,18	233	140x10	20H7	193
73	230,55	232,37	236	140x10	20H7	197
74	233,73	235,55	239	140x10	20H7	201
75	236,91	238,73	242	140x10	20H7	203
76	240,10	241,92	246	140x10	20H7	207
77	243,28	245,10	249	160x10	20H7	209
78	246,46	248,28	252	160x10	20H7	213
79	249,64	251,46	255	160x10	20H7	215

z	Hub			Bore		
	d <sub>K</sub> [mm]	d <sub>0</sub> [mm]	d <sub>B</sub> [mm]	d <sub>N</sub> x l <sub>N</sub> [mm]	d <sub>V</sub> [mm]	d <sub>max</sub> [mm]
80	252,83	254,65	258	160x10	20H7	219
81	256,01	257,83	262	160x10	20H7	223
82	259,19	261,01	265	160x10	20H7	225
83	262,38	264,20	268	160x10	20H7	229
84	265,56	267,38	271	160x10	20H7	231
85	268,74	270,56	274	160x10	20H7	235
86	271,93	273,75	277	160x10	20H7	239
87	275,11	276,93	281	160x10	20H7	241
88	278,29	280,11	284	160x10	20H7	245
89	281,48	283,30	287	160x10	20H7	247
90	284,66	286,48	290	160x10	20H7	251
91	287,84	289,66	293	160x10	20H7	255
92	291,03	292,85	296	160x10	20H7	257
93	294,21	296,03	299	160x10	20H7	261
94	297,39	299,21	302	160x10	20H7	263
95	300,57	302,39	306	160x10	24H7	267
96	303,76	305,58	310	180x10	24H7	269
97	306,94	308,76	312	180x10	24H7	273
98	310,12	311,94	315	180x10	24H7	279
99	313,31	315,13	318	180x10	24H7	283
100	316,49	318,31	322	180x10	24H7	285
101	319,67	321,49	325	180x10	24H7	289
102	322,86	324,68	329	180x10	24H7	293
103	326,04	327,86	332	180x10	24H7	295
104	329,22	331,04	335	180x10	24H7	299
105	332,41	334,23	338	180x10	24H7	301
106	335,59	337,41	341	180x10	24H7	305
107	338,77	340,59	344	180x10	24H7	309
108	341,95	343,77	348	180x10	24H7	311
109	345,14	346,96	351	180x10	24H7	315
110	348,32	350,14	354	180x10	24H7	317
111	351,50	353,32	357	180x10	24H7	321
112	354,69	356,51	360	180x10	24H7	323
113	357,87	359,69	363	180x10	24H7	327
114	361,05	362,87	367	180x10	24H7	330

# Timing pulleys AT-Profile

## AT 20 (Also for ATN toothed belt)

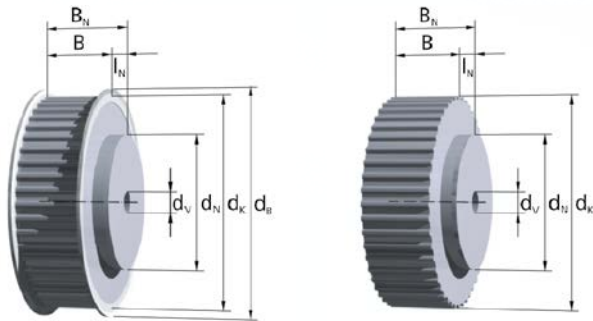

**Order example:**

Pulley AL 70 AT 20 / 60 - 0 Hub 140x10; dv  
 Material \_\_\_\_\_  
 Total width  $B_N$  \_\_\_\_\_  
 Type / pitch \_\_\_\_\_  
 Number of teeth \_\_\_\_\_  
 Number of flanges \_\_\_\_\_  
 Hub dimension  $d_N \times l_N$  \_\_\_\_\_

Note for part code:

$d_v$  = Diameter pre-drilled.

Refer to page 14 for further ordering information.

Belt width	b [mm]	32	50	75	100
Pulley width	B [mm]	40	60	85	110
Width für ATN-System	B [mm]	-	60	85	110
Total width	$B_N$ [mm]	50	70	95	120

**Materials:**

Pulley: AlCu4MgSi, RoHS-conformant  
 Flange: Galvanized steel, screwed

**In-between widths and larger widths are available (not with ATN toothed belts).**

Other dimensions.

- $z$  = Number of teeth
- $d_k$  = Outside diameter
- $d_0$  = Pitch circle diameter
- $d_B$  = Flange diameter
- $d_N$  = Hub diameter

- $l_N$  = Hub length
- $d_v$  = Pre-bore diameter
- $d_{max}$  = max. bore diameter without keyway for flanged timing pulleys; no hub at maximum pre-bore

z	$d_k$ [mm]	$d_0$ [mm]	$d_B$ [mm]	Hub		Bore	
				$d_N \times l_N$ [mm]	$d_v$ [mm]	$d_{max}$ [mm]	
18	111,77	114,59	121	70x10	12H7	86	
19	118,14	120,96	128	80x10	12H7	93	
20	124,50	127,32	134	90x10	16H7	100	
21	130,87	133,69	140	90x10	16H7	105	
22	137,24	140,06	147	90x10	16H7	112	
23	143,60	146,42	153	90x10	16H7	118	
24	149,97	152,79	160	95x10	16H7	125	
25	156,33	159,15	166	95x10	16H7	131	
26	162,70	165,52	172	95x10	16H7	137	
27	169,07	171,89	179	110x10	16H7	144	
28	175,43	178,25	185	110x10	16H7	150	
29	181,80	184,62	192	110x10	16H7	156	

z	$d_k$ [mm]	$d_0$ [mm]	$d_B$ [mm]	Hub		Bore	
				$d_N \times l_N$ [mm]	$d_v$ [mm]	$d_{max}$ [mm]	
30	188,17	190,99	198	110x10	16H7	163	
31	194,53	197,35	204	110x10	16H7	169	
32	200,90	203,72	210	110x10	16H7	175	
33	207,26	210,08	217	110x10	16H7	182	
34	213,63	216,45	223	110x10	16H7	188	
35	220,00	222,82	229	110x10	16H7	195	
36	226,36	229,18	236	110x10	18H7	201	
37	232,73	235,55	242	110x10	18H7	207	
38	239,10	241,92	249	110x10	18H7	214	
39	245,46	248,28	255	110x10	18H7	220	
40	251,83	254,65	261	110x10	18H7	226	
41	258,19	261,01	268	130x10	18H7	233	
42	264,56	267,38	274	130x10	18H7	239	
43	270,93	273,75	280	130x10	18H7	245	
44	277,29	280,11	287	130x10	18H7	252	

# AT 20 (Also for ATN toothed belt)

z	Hub			Bore		
	d <sub>K</sub> [mm]	d <sub>0</sub> [mm]	d <sub>B</sub> [mm]	d <sub>N</sub> x l <sub>N</sub> [mm]	d <sub>V</sub> [mm]	d <sub>max</sub> [mm]
45	283,66	286,48	293	130x10	18H7	258
46	290,03	292,85	300	130x10	18H7	265
47	296,39	299,21	306	130x10	18H7	271
48	302,76	305,58	312	130x10	18H7	278
49	309,12	311,94	319	140x10	20H7	284
50	315,49	318,31	325	140x10	20H7	290
51	322,86	324,68	331	140x10	20H7	296
52	328,22	331,04	338	140x10	20H7	303
53	334,59	337,41	344	140x10	20H7	310
54	340,95	343,77	350	140x10	20H7	315
55	347,32	350,14	357	140x10	20H7	322
56	353,69	356,51	363	140x10	20H7	328
57	360,05	362,87	370	140x10	20H7	335
58	366,42	369,24	376	140x10	20H7	341
59	372,79	375,61	382	140x10	20H7	347
60	379,15	381,97	389	140x10	20H7	354
61	385,52	388,34	395	140x10	20H7	360
62	391,88	394,70	401	140x10	20H7	366
63	398,25	401,07	408	140x10	20H7	373
64	404,62	407,44	414	140x10	20H7	379
65	410,98	413,80	420	140x10	20H7	385
66	417,35	420,17	427	140x10	20H7	392
67	423,72	426,54	433	140x10	20H7	398
68	430,08	432,90	440	140x10	20H7	405
69	436,45	439,27	446	140x10	20H7	406
70	442,81	445,63	452	140x10	20H7	412
71	449,18	452,00	459	140x10	20H7	419
72	455,55	458,37	465	140x10	20H7	425
73	461,91	464,73	471	160x10	30H7	431
74	468,28	471,10	478	160x10	30H7	438
75	474,64	477,46	484	160x10	30H7	444
76	481,01	483,83	490	160x10	30H7	450
77	487,38	490,20	497	160x10	30H7	457
78	493,74	496,56	503	160x10	30H7	463
79	500,11	502,93	510	160x10	30H7	470

z	Hub			Bore		
	d <sub>K</sub> [mm]	d <sub>0</sub> [mm]	d <sub>B</sub> [mm]	d <sub>N</sub> x l <sub>N</sub> [mm]	d <sub>V</sub> [mm]	d <sub>max</sub> [mm]
80	506,48	509,30	516	200x10	30H7	476
81	512,84	515,66	522	200x10	30H7	482
82	519,21	522,03	529	200x10	30H7	489
83	525,57	528,39	535	200x10	30H7	495
84	531,94	534,76	541	200x10	30H7	501
85	538,31	541,13	548	200x10	30H7	503
86	544,67	547,49	554	200x10	30H7	509
87	551,04	553,86	561	200x10	30H7	516
88	557,41	560,23	567	200x10	30H7	522
89	563,77	566,59	573	200x10	30H7	528
90	570,14	572,96	580	200x10	30H7	535
91	576,50	579,32	586	200x10	30H7	541
92	582,87	585,69	592	200x10	30H7	548
93	589,24	592,06	599	200x10	30H7	554
94	595,60	598,42	605	200x10	30H7	560
95	601,97	604,79	611	200x10	40H7	566
96	608,33	611,15	618	200x10	40H7	573
97	614,70	617,52	624	200x10	40H7	579
98	621,07	623,89	631	200x10	40H7	586
99	627,43	630,25	637	200x10	40H7	592
100	633,80	636,62	643	200x10	40H7	598
101	640,17	642,99	650	200x10	40H7	605
102	646,53	649,35	656	200x10	40H7	611
103	652,90	655,72	662	200x10	40H7	617
104	659,26	662,08	669	200x10	40H7	624
105	665,63	668,45	675	200x10	40H7	630
106	672,00	674,82	681	200x10	40H7	636
107	678,36	681,18	688	200x10	40H7	643
108	684,73	687,55	694	200x10	40H7	649
109	691,10	693,92	701	200x10	40H7	656
110	697,46	700,28	707	200x10	40H7	662
111	703,83	706,65	713	200x10	40H7	663
112	710,19	713,01	720	200x10	40H7	670
113	716,56	719,38	726	200x10	40H7	676
114	722,93	725,75	732	200x10	40H7	682

# Timing pulleys ATP-Profile

## ATP 10

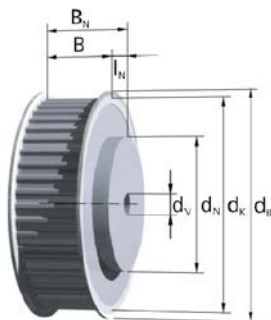

Stock-Pulleys with flanges

**Order example:**

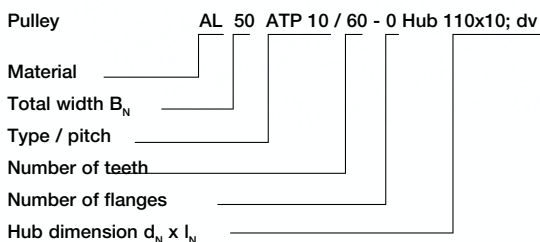

Note for part code:

dv = Diameter pre-drilled.

Refer to page 14 for further ordering information.

Belt width	b	[mm]	16	25	32	50	75	100
Pulley width	B	[mm]	23	32	40	60	85	110
Total width	$B_N$	[mm]	33	42	50	70	95	120

**Materials:**

Pulley: AlZn5Mg3Cu  
 Flange: Galvanized steel

The stock pulleys with standard dimensioning are marked in blue.

In-between widths and larger widths as well as other hub dimensions are available.

- z = Number of teeth
- $d_k$  = Outside diameter
- $d_0$  = Pitch circle diameter
- $d_B$  = Flange diameter
- $d_N$  = Hub diameter

- $l_N$  = Hub length
- $d_v$  = Pre-bore diameter
- $d_{max}$  = max. bore diameter without keyway for flanged timing pulleys; no hub at maximum pre-bore

z	$d_k$ [mm]	$d_0$ [mm]	$d_B$ [mm]	Hub		Bore	
				$d_N \times l_N$ [mm]	$d_v$ [mm]	$d_{max}$ [mm]	
15	46,15	45,93	52	32x10	8H7	19	
16	49,33	49,11	55	35x10	8H7	23	
17	52,51	52,29	58	40x10	10H7	26	
18	55,70	55,48	61	40x10	10H7	29	
19	58,88	58,66	64	44x10	10H7	32	
20	62,06	61,84	68	46x10	12H7	34	
21	65,25	65,03	72	46x10	12H7	35	
22	68,43	68,21	74	50x10	12H7	39	
23	71,61	71,39	78	50x10	12H7	42	
24	74,79	74,57	80	58x10	12H7	45	
25	77,98	77,76	84	60x10	12H7	48	
26	81,16	80,94	87	60x10	12H7	51	
27	84,34	84,12	90	60x10	12H7	55	
28	87,53	87,31	93	60x10	12H7	58	
29	90,71	90,49	96	60x10	12H7	61	

z	$d_k$ [mm]	$d_0$ [mm]	$d_B$ [mm]	Hub		Bore	
				$d_N \times l_N$ [mm]	$d_v$ [mm]	$d_{max}$ [mm]	
30	93,89	95,49	99	60x10	12H7	64	
31	97,08	98,68	102	60x10	12H7	67	
32	100,26	101,86	105	65x10	12H7	71	
33	103,44	105,04	109	65x10	12H7	74	
34	106,63	108,23	112	65x10	12H7	77	
35	109,81	111,41	115	65x10	12H7	80	
36	112,99	114,59	118	70x10	16H7	83	
37	116,17	117,77	121	70x10	16H7	86	
38	119,36	120,96	125	70x10	16H7	90	
39	122,54	124,14	128	70x10	16H7	93	
40	125,72	127,32	131	80x10	16H7	96	
41	128,91	130,51	134	80x10	16H7	99	
42	132,09	133,69	137	80x10	16H7	102	
43	135,27	136,87	140	80x10	16H7	104	
44	138,46	140,06	144	90x10	16H7	109	



## ATP 10

z	Hub			Bore		
	d <sub>K</sub> [mm]	d <sub>0</sub> [mm]	d <sub>B</sub> [mm]	d <sub>N</sub> x l <sub>N</sub> [mm]	d <sub>V</sub> [mm]	d <sub>max</sub> [mm]
45	141,64	143,24	147	90x10	16H7	112
46	144,82	146,42	150	90x10	16H7	115
47	148,01	149,61	153	90x10	16H7	118
48	151,19	152,79	156	95x10	16H7	121
49	154,37	155,97	160	95x10	16H7	125
50	157,56	159,15	163	95x10	16H7	128
51	160,74	162,34	166	95x10	16H7	132
52	163,92	165,52	169	95x10	16H7	134
53	167,10	168,70	172	95x10	16H7	137
54	170,29	171,89	176	110x10	16H7	141
55	173,47	175,07	179	110x10	16H7	144
56	176,65	178,25	182	110x10	16H7	147
57	179,84	181,44	185	110x10	16H7	150
58	183,02	184,62	188	110x10	16H7	153
59	186,20	187,80	191	110x10	16H7	156
60	189,39	190,99	195	110x10	16H7	160
61	192,57	194,17	198	110x10	16H7	163
62	195,75	197,35	201	110x10	16H7	166
63	198,94	200,54	204	140x10	16H7	169
64	202,12	203,72	207	140x10	16H7	172
65	205,30	206,90	210	140x10	16H7	176
66	208,48	210,08	214	140x10	16H7	179
67	211,67	213,27	217	140x10	16H7	182
68	214,85	216,45	220	140x10	16H7	185
69	218,03	219,63	223	140x10	16H7	188
70	221,22	222,82	226	140x10	16H7	191
71	224,40	226,00	230	140x10	16H7	196
72	227,58	229,18	233	140x10	16H7	198
73	230,77	232,37	236	140x10	16H7	201
74	233,95	235,55	239	140x10	20H7	204
75	237,13	238,73	242	140x10	20H7	207
76	240,32	241,92	246	140x10	20H7	211
77	243,50	245,10	249	160x10	20H7	214
78	246,68	248,28	252	160x10	20H7	217
79	249,87	251,46	255	160x10	20H7	220

z	Hub			Bore		
	d <sub>K</sub> [mm]	d <sub>0</sub> [mm]	d <sub>B</sub> [mm]	d <sub>N</sub> x l <sub>N</sub> [mm]	d <sub>V</sub> [mm]	d <sub>max</sub> [mm]
80	253,05	254,65	258	160x10	20H7	223
81	256,23	257,83	262	160x10	20H7	226
82	259,41	261,01	265	160x10	20H7	230
83	262,60	264,20	268	160x10	20H7	233
84	265,78	267,38	271	160x10	20H7	236
85	268,96	270,56	274	160x10	20H7	239
86	272,15	273,75	277	160x10	20H7	242
87	275,33	276,93	281	160x10	20H7	245
88	278,51	280,11	284	160x10	20H7	249
89	281,70	283,30	287	160x10	20H7	252
90	284,88	286,48	290	160x10	20H7	255
91	288,06	289,66	293	160x10	20H7	258
92	291,25	292,85	296	160x10	20H7	261
93	294,43	296,03	300	160x10	20H7	263
94	297,61	299,21	302	160x10	20H7	268
95	300,79	302,39	306	160x10	24H7	271
96	303,98	305,58	310	180x10	24H7	274
97	307,16	308,76	312	180x10	24H7	277
98	310,34	311,94	315	180x10	24H7	281
99	313,53	315,13	318	180x10	24H7	284
100	316,71	318,31	322	180x10	24H7	287
101	319,89	321,49	325	180x10	24H7	290
102	323,08	324,68	329	180x10	24H7	293
103	326,26	327,86	332	180x10	24H7	297
104	329,44	331,04	335	180x10	24H7	300
105	332,63	334,23	338	180x10	24H7	303
106	335,81	337,41	341	180x10	24H7	306
107	338,99	340,59	344	180x10	24H7	309
108	342,17	343,77	348	180x10	24H7	312
109	345,36	346,96	351	180x10	24H7	316
110	348,54	350,14	354	180x10	24H7	319
111	351,72	353,32	357	180x10	24H7	322
112	354,91	356,51	360	180x10	24H7	325
113	358,09	359,69	363	180x10	24H7	328
114	361,27	362,87	367	180x10	24H7	332

# Timing pulleys ATP-Profile

## ATP 15

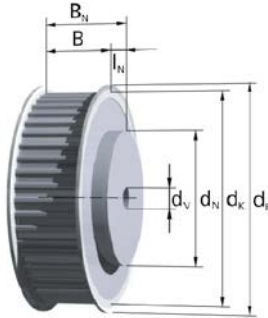

Stock-Pulleys with flanges

**Order example:**

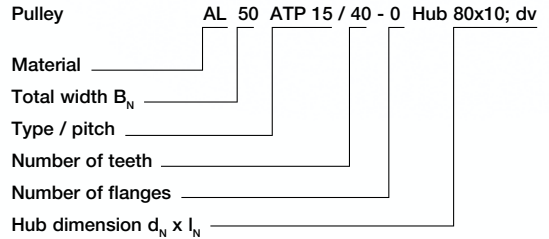

Note for part code:

dv = Diameter pre-drilled.

Refer to page 14 for further ordering information.

Belt width	b [mm]	25	32	50	75	100	150
Pulley width	B [mm]	32	40	60	85	110	160
Total width	B <sub>N</sub> [mm]	42	50	70	95	120	170

**Materials:**

Pulley: AlZn5Mg3Cu  
 Flange: Galvanized steel

The stock pulleys with standard dimensioning are marked in blue.

In-between widths and larger widths as well as other hub dimensions are available.

- z = Number of teeth
- d<sub>k</sub> = Outside diameter
- d<sub>0</sub> = Pitch circle diameter
- d<sub>B</sub> = Flange diameter
- d<sub>N</sub> = Hub diameter

- l<sub>N</sub> = Hub length
- d<sub>v</sub> = Pre-bore diameter
- d<sub>max</sub> = max. bore diameter without keyway for flanged timing pulleys; no hub at maximum pre-bore

z	d <sub>k</sub> [mm]	d <sub>0</sub> [mm]	d <sub>B</sub> [mm]	Hub d <sub>N</sub> x l <sub>N</sub> [mm]	Bore d <sub>v</sub> [mm]	d <sub>max</sub> [mm]
20	93,39	95,49	100	46x10	12H7	64
21	98,17	100,27	106	46x10	12H7	71
22	102,94	105,04	109	50x10	12H7	74
23	107,72	109,82	115	50x10	12H7	77
24	112,49	114,59	118	50x10	12H7	83
25	117,27	119,37	125	50x10	12H7	90
26	122,04	124,14	128	50x10	12H7	93
27	126,82	128,92	134	50x10	12H7	99
28	131,59	133,69	137	58x10	12H7	102
29	136,36	138,46	144	58x10	12H7	109

z	d <sub>k</sub> [mm]	d <sub>0</sub> [mm]	d <sub>B</sub> [mm]	Hub d <sub>N</sub> x l <sub>N</sub> [mm]	Bore d <sub>v</sub> [mm]	d <sub>max</sub> [mm]
30	141,14	143,24	147	60x10	12H7	112
31	145,91	148,01	153	60x10	12H7	118
32	150,69	152,79	156	65x10	12H7	121
33	155,46	157,56	163	65x10	12H7	128
34	160,24	162,34	166	65x10	16H7	131
35	165,01	167,11	172	65x10	16H7	137
36	169,79	171,89	176	70x10	16H7	141
37	174,56	176,66	182	70x10	16H7	147
38	179,34	181,44	185	70x10	16H7	150
39	184,11	186,21	191	70x10	16H7	156
40	188,89	190,99	195	80x10	16H7	160
41	193,66	195,76	201	110x10	16H7	166
42	198,44	200,54	204	110x10	16H7	169
43	203,21	205,31	210	140x10	16H7	176
44	207,98	210,08	214	140x10	16H7	179

## ATP 15

z	Hub			Bore		
	d <sub>K</sub> [mm]	d <sub>0</sub> [mm]	d <sub>B</sub> [mm]	d <sub>N</sub> x l <sub>N</sub> [mm]	d <sub>V</sub> [mm]	d <sub>max</sub> [mm]
45	212,76	214,86	220	140x10	16H7	185
46	217,53	219,63	223	140x10	16H7	188
47	222,31	224,41	230	140x10	16H7	195
48	227,08	229,18	234	140x10	16H7	198
49	231,86	233,96	239	140x10	16H7	204
50	236,63	238,73	242	140x10	16H7	207
51	241,41	243,51	249	140x10	16H7	214
52	246,18	248,28	252	140x10	16H7	217
53	250,96	253,06	258	160x10	20H7	223
54	255,73	257,83	262	160x10	20H7	226
55	260,51	262,61	268	160x10	20H7	233
56	265,28	267,38	271	160x10	20H7	236
57	270,05	272,15	277	160x10	20H7	242
58	274,83	276,93	281	160x10	20H7	245
59	279,60	281,70	287	160x10	20H7	252
60	284,38	286,48	290	160x10	20H7	255
61	289,15	291,25	296	160x10	20H7	261
62	293,93	296,03	300	160x10	20H7	265
63	298,70	300,80	306	160x10	20H7	271
64	303,48	305,58	310	160x10	24H7	274
65	308,25	310,35	315	160x10	24H7	281
66	313,03	315,13	319	160x10	24H7	284
67	317,80	319,90	325	160x10	24H7	290
68	322,58	324,68	329	160x10	24H7	293
69	327,35	329,45	335	160x10	24H7	300
70	332,13	334,23	338	160x10	24H7	303
71	336,90	339,00	344	160x10	24H7	309
72	341,67	343,77	348	160x10	24H7	314
73	346,45	348,55	354	160x10	24H7	319
74	351,22	353,32	357	160x10	24H7	322
75	356,00	358,10	363	160x10	24H7	328
76	360,77	362,87	367	160x10	24H7	332
77	365,55	367,65	372	160x10	24H7	334
78	370,32	372,42	377	160x10	24H7	339
79	375,10	377,20	382	160x10	24H7	344

z	Hub			Bore		
	d <sub>K</sub> [mm]	d <sub>0</sub> [mm]	d <sub>B</sub> [mm]	d <sub>N</sub> x l <sub>N</sub> [mm]	d <sub>V</sub> [mm]	d <sub>max</sub> [mm]
80	379,87	381,97	386	160x10	24H7	348
81	384,65	386,75	391	160x10	24H7	353
82	389,42	391,52	396	160x10	24H7	358
83	394,20	396,30	401	160x10	24H7	363
84	398,97	401,07	405	160x10	24H7	367
85	403,75	405,85	410	200x10	30H7	372
86	408,52	410,62	415	200x10	30H7	377
87	413,29	415,39	420	200x10	30H7	382
88	418,07	420,17	425	200x10	30H7	387
89	422,84	424,94	429	200x10	30H7	391
90	427,62	429,72	434	200x10	30H7	396
91	432,39	434,49	440	200x10	30H7	401
92	437,17	439,27	444	200x10	30H7	406
93	441,94	444,04	448	200x10	30H7	410
94	446,72	448,82	453	200x10	30H7	415
95	451,49	453,59	459	200x10	30H7	420
96	456,27	458,37	463	200x10	30H7	425
97	461,04	463,14	468	200x10	30H7	430
98	465,82	467,92	472	200x10	30H7	434
99	470,59	472,69	478	200x10	30H7	439
100	475,36	477,46	482	200x10	30H7	444
101	480,14	482,24	487	200x10	30H7	449
102	484,91	487,01	491	200x10	30H7	453
103	489,69	491,97	497	200x10	30H7	458
104	494,46	496,56	501	200x10	30H7	463
105	499,24	501,34	506	200x10	30H7	468
106	504,01	506,11	511	200x10	30H7	473
107	508,79	510,89	516	200x10	30H7	477
108	513,56	515,66	520	200x10	30H7	482
109	518,34	520,44	525	200x10	30H7	487
110	523,11	525,21	530	200x10	30H7	492
111	527,89	529,99	535	200x10	30H7	496
112	532,66	534,76	539	200x10	30H7	501
113	537,44	539,54	544	200x10	30H7	506
114	542,21	544,31	549	200x10	30H7	512

# Timing pulleys self-tracking Profiles

## BAT 10

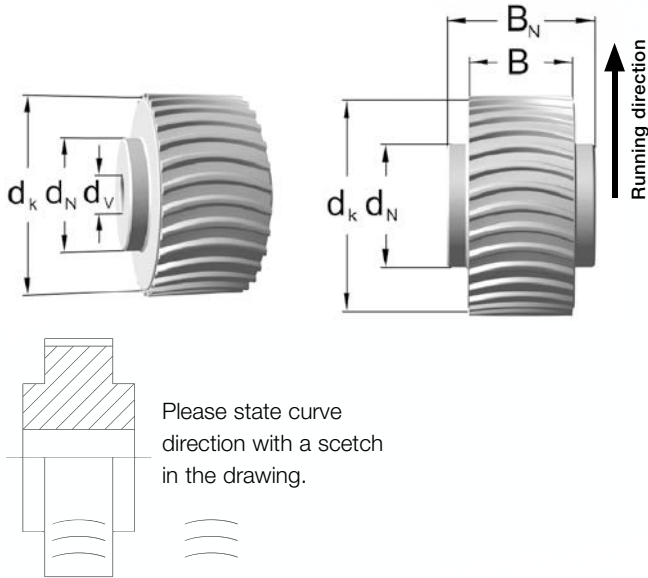

### Order example:

Pulley Al 115 BAT 10 / 25 double Hub 59x5 d=30H7 with keyway  
 Material \_\_\_\_\_  
 Width  $B_N$  \_\_\_\_\_  
 Type / pitch \_\_\_\_\_  
 Number of teeth \_\_\_\_\_  
 Hub dimension ( $d_N \times l_N$ ) \_\_\_\_\_  
 Bore \_\_\_\_\_  
 Keyway to DIN 6685 \_\_\_\_\_

Refer to page 14 for further ordering information.

Belt width	b	[mm]	25	32	50	75	100
Pulley width	B	[mm]	30	35	55	80	105
Total width	$B_N$	[mm]	40	47	65	90	115

### Material:

Pulley: AlCu4MgSi, RoHS-conformant

In-between widths and larger widths as well as other hub dimensions are available.

- $z$  = Number of teeth
- $d_k$  = Outside diameter
- $d_0$  = Pitch circle diameter
- $d_B$  = Flange diameter
- $d_N$  = Hub diameter

- $l_N$  = Hub length
- $d_V$  = Pre-bore diameter
- $d_{max}$  = max. bore diameter without keyway for flanged timing pulleys; no hub at maximum pre-bore

z	$d_k$ [mm]	$d_0$ [mm]	Hub		Bore	
			$d_B$ [mm]	$d_N \times l_N$ [mm]	$d_V$ [mm]	$d_{max}$ [mm]
20	61,84	63,66	67	46x5	12H7	50
21	65,03	66,85	70	50x5	12H7	52
22	68,21	70,03	74	53x5	12H7	56
23	71,39	73,21	76	56x5	12H7	60
24	74,57	76,39	80	57x5	12H7	62

z	$d_k$ [mm]	$d_0$ [mm]	Hub		Bore	
			$d_B$ [mm]	$d_N \times l_N$ [mm]	$d_V$ [mm]	$d_{max}$ [mm]
25	77,76	79,58	82	59x5	12H7	66
26	80,94	82,76	86	62x5	12H7	68
27	84,12	85,94	90	64x5	12H7	72
28	87,31	89,13	93	67x5	12H7	76
29	90,49	92,31	96	70x5	12H7	78
30	93,67	95,49	99	73x5	12H7	82
31	96,86	98,68	102	77x5	12H7	84
32	100,04	101,86	105	80x5	12H7	88
33	103,22	105,04	109	83x5	12H7	88
34	106,41	108,23	112	86x5	12H7	92



# BAT 10

z	Hub			Bore		
	d <sub>K</sub> [mm]	d <sub>0</sub> [mm]	d <sub>B</sub> [mm]	d <sub>N</sub> × l <sub>N</sub> [mm]	d <sub>V</sub> [mm]	d <sub>max</sub> [mm]
35	109,59	111,41	115	90x5	16H7	96
36	112,77	114,59	118	92x5	16H7	98
37	115,95	117,77	121	95x5	16H7	101
38	119,14	120,96	125	99x5	16H7	104
39	122,32	124,14	128	102x5	16H7	106
40	125,50	127,32	131	105x5	16H7	110
41	128,69	130,51	134	108x5	16H7	110
42	131,87	133,69	137	111x5	16H7	112
43	135,05	136,87	140	115x5	16H7	114
44	138,24	140,06	144	118x5	16H7	118
45	141,42	143,24	147	121x5	16H7	120
46	144,60	146,42	150	124x5	16H7	122
47	147,79	149,61	153	127x5	16H7	122
48	150,97	152,79	156	130x5	20H7	124
49	154,15	155,97	160	134x5	20H7	126
50	157,33	159,15	162	137x5	20H7	130
51	160,52	162,34	166	140x5	20H7	134
52	163,70	165,52	169	143x5	20H7	136
53	166,88	168,70	172	146x5	20H7	140
54	170,07	171,89	176	150x5	20H7	144
55	173,25	175,07	178	153x5	20H7	146
56	176,43	178,25	182	156x5	20H7	150
57	179,62	181,44	185	159x5	20H7	152
58	182,80	184,62	188	162x5	20H7	156
59	185,98	187,80	191	165x5	20H7	160
60	189,17	190,99	195	169x5	20H7	162
61	192,35	194,17	198	172x5	20H7	164
62	195,53	197,35	201	175x5	20H7	166
63	198,72	200,54	204	178x5	20H7	170
64	201,90	203,72	207	181x5	20H7	171
65	205,08	206,90	210	185x5	20H7	174
66	208,26	210,08	214	188x5	20H7	175
67	211,45	213,27	217	191x5	20H7	177
68	214,63	216,45	220	194x5	20H7	181
69	217,81	219,63	223	197x5	20H7	185
70	221,00	222,82	226	201x5	20H7	187
71	224,18	226,00	230	204x5	20H7	191
72	227,36	229,18	232	207x5	20H7	193
73	230,55	232,37	236	210x5	20H7	197
74	233,73	235,55	239	213x5	20H7	201

z	Hub			Bore		
	d <sub>K</sub> [mm]	d <sub>0</sub> [mm]	d <sub>B</sub> [mm]	d <sub>N</sub> × l <sub>N</sub> [mm]	d <sub>V</sub> [mm]	d <sub>max</sub> [mm]
75	236,91	238,73	242	216x5	20H7	203
76	240,10	241,92	246	220x5	20H7	207
77	243,28	245,10	249	223x5	20H7	209
78	246,46	248,28	252	226x5	20H7	213
79	249,64	251,46	255	229x5	20H7	215
80	252,83	254,65	258	232x5	20H7	219
81	256,01	257,83	261	236x5	20H7	223
82	259,19	261,01	265	239x5	20H7	225
83	262,38	264,20	268	242x5	20H7	229
84	265,56	267,38	271	245x5	20H7	231
85	268,74	270,56	274	248x5	20H7	235
86	271,93	273,75	277	251x5	20H7	239
87	275,11	276,93	280	255x5	20H7	241
88	278,29	280,11	284	258x5	20H7	245
89	281,48	283,30	287	261x5	20H7	247
90	284,66	286,48	290	264x5	20H7	251
91	287,84	289,66	293	267x5	20H7	255
92	291,03	292,85	296	271x5	20H7	257
93	294,21	296,03	300	274x5	20H7	261
94	297,39	299,21	302	277x5	20H7	263
95	300,57	302,39	306	280x5	24H7	267
96	303,76	305,58	309	283x5	24H7	269
97	306,94	308,76	312	286x5	24H7	273
98	310,12	311,94	315	290x5	24H7	279
99	313,31	315,13	318	293x5	24H7	283
100	316,49	318,31	322	296x5	24H7	285
101	319,67	321,49	325	299x5	24H7	289
102	322,86	324,68	328	302x5	24H7	293
103	326,04	327,86	332	306x5	24H7	295
104	329,22	331,04	335	309x5	24H7	299
105	332,41	334,23	338	312x5	24H7	301
106	335,59	337,41	341	315x5	24H7	305
107	338,77	340,59	344	318x5	24H7	309
108	341,95	343,77	347	321x5	24H7	311
109	345,14	346,96	351	325x5	24H7	315
110	348,32	350,14	354	328x5	24H7	317
111	351,50	353,32	357	331x5	24H7	321
112	354,69	356,51	360	334x5	24H7	323
113	357,87	359,69	363	337x5	24H7	327
114	361,05	362,87	367	341x5	24H7	330

# Timing pulleys self-tracking Profiles

## BATK 10

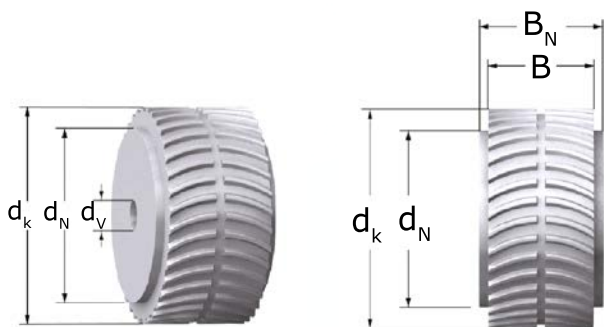

### Order example:

Pulley Al 115 BATK 10 / 25 double Hub 59x5 d=30H7 with keyway  
 Material \_\_\_\_\_  
 Width  $B_N$  \_\_\_\_\_  
 Type / pitch \_\_\_\_\_  
 Number of teeth \_\_\_\_\_  
 Hub dimension ( $d_N \times l_N$ ) \_\_\_\_\_  
 Bore \_\_\_\_\_  
 Keyway to DIN 6685 \_\_\_\_\_

Refer to page 14 for further ordering information.

Belt width	b [mm]	32	50	75	100
Pulley width	B [mm]	37	55	80	105
Total width	$B_N$ [mm]	47	65	90	115

### Material:

Timing pulley: AlCu4MgSi, RoHS-conformant

### Other dimensions.

- z = Number of teeth
- $d_k$  = Outside diameter
- $d_o$  = Pitch circle diameter
- $d_N$  = Hub diameter
- $l_N$  = Hub length
- $d_v$  = Pre-bore diameter
- $d_{max}$  = max. bore diameter without keyway for flanged timing pulleys; no hub at maximum pre-bore

z	Hub		Bore		
	$d_k$ [mm]	$d_o$ [mm]	$d_N \times l_N$ [mm]	$d_v$ [mm]	$d_{max}$ [mm]
20	61,84	63,66	46x5	12H7	50
21	65,03	66,85	50x5	12H7	52
22	68,21	70,03	53x5	12H7	56
23	71,39	73,21	56x5	12H7	60
24	74,57	76,39	57x5	12H7	62

z	Hub		Bore		
	$d_k$ [mm]	$d_o$ [mm]	$d_N \times l_N$ [mm]	$d_v$ [mm]	$d_{max}$ [mm]
25	77,76	79,58	59x5	12H7	66
26	80,94	82,76	62x5	12H7	68
27	84,12	85,94	64x5	12H7	72
28	87,31	89,13	67x5	12H7	76
29	90,49	92,31	70x5	12H7	78
30	93,67	95,49	73x5	12H7	82
31	96,86	98,68	77x5	12H7	84
32	100,04	101,86	80x5	12H7	88
33	103,22	105,04	83x5	12H7	88
34	106,41	108,23	86x5	12H7	92

# BATK 10

z			Hub	Bore	
	d <sub>k</sub> [mm]	d <sub>0</sub> [mm]	d <sub>N</sub> x l <sub>N</sub> [mm]	d <sub>v</sub> [mm]	d <sub>max</sub> [mm]
35	109,59	111,41	90x5	16H7	96
36	112,77	114,59	92x5	16H7	98
37	115,95	117,77	95x5	16H7	101
38	119,14	120,96	99x5	16H7	104
39	122,32	124,14	102x5	16H7	106
40	125,50	127,32	105x5	16H7	110
41	128,69	130,51	108x5	16H7	110
42	131,87	133,69	111x5	16H7	112
43	135,05	136,87	115x5	16H7	114
44	138,24	140,06	118x5	16H7	118
45	141,42	143,24	121x5	16H7	120
46	144,60	146,42	124x5	16H7	122
47	147,79	149,61	127x5	16H7	122
48	150,97	152,79	130x5	20H7	124
49	154,15	155,97	134x5	20H7	126
50	157,33	159,15	137x5	20H7	130
51	160,52	162,34	140x5	20H7	134
52	163,70	165,52	143x5	20H7	136
53	166,88	168,70	146x5	20H7	140
54	170,07	171,89	150x5	20H7	144
55	173,25	175,07	153x5	20H7	146
56	176,43	178,25	156x5	20H7	150
57	179,62	181,44	159x5	20H7	152
58	182,80	184,62	162x5	20H7	156
59	185,98	187,80	165x5	20H7	160
60	189,17	190,99	169x5	20H7	162
61	192,35	194,17	172x5	20H7	164
62	195,53	197,35	175x5	20H7	166
63	198,72	200,54	178x5	20H7	170
64	201,90	203,72	181x5	20H7	171
65	205,08	206,90	185x5	20H7	174
66	208,26	210,08	188x5	20H7	175
67	211,45	213,27	191x5	20H7	177
68	214,63	216,45	194x5	20H7	181
69	217,81	219,63	197x5	20H7	185
70	221,00	222,82	201x5	20H7	187
71	224,18	226,00	204x5	20H7	191
72	227,36	229,18	207x5	20H7	193
73	230,55	232,37	210x5	20H7	197
74	233,73	235,55	213x5	20H7	201

z			Hub	Bore	
	d <sub>k</sub> [mm]	d <sub>0</sub> [mm]	d <sub>N</sub> x l <sub>N</sub> [mm]	d <sub>v</sub> [mm]	d <sub>max</sub> [mm]
75	236,91	238,73	216x5	20H7	203
76	240,10	241,92	220x5	20H7	207
77	243,28	245,10	223x5	20H7	209
78	246,46	248,28	226x5	20H7	213
79	249,64	251,46	229x5	20H7	215
80	252,83	254,65	232x5	20H7	219
81	256,01	257,83	236x5	20H7	223
82	259,19	261,01	239x5	20H7	225
83	262,38	264,20	242x5	20H7	229
84	265,56	267,38	245x5	20H7	231
85	268,74	270,56	248x5	20H7	235
86	271,93	273,75	251x5	20H7	239
87	275,11	276,93	255x5	20H7	241
88	278,29	280,11	258x5	20H7	245
89	281,48	283,30	261x5	20H7	247
90	284,66	286,48	264x5	20H7	251
91	287,84	289,66	267x5	20H7	255
92	291,03	292,85	271x5	20H7	257
93	294,21	296,03	274x5	20H7	261
94	297,39	299,21	277x5	20H7	263
95	300,57	302,39	280x5	24H7	267
96	303,76	305,58	283x5	24H7	269
97	306,94	308,76	286x5	24H7	273
98	310,12	311,94	290x5	24H7	279
99	313,31	315,13	293x5	24H7	283
100	316,49	318,31	296x5	24H7	285
101	319,67	321,49	299x5	24H7	289
102	322,86	324,68	302x5	24H7	293
103	326,04	327,86	306x5	24H7	295
104	329,22	331,04	309x5	24H7	299
105	332,41	334,23	312x5	24H7	301
106	335,59	337,41	315x5	24H7	305
107	338,77	340,59	318x5	24H7	309
108	341,95	343,77	321x5	24H7	311
109	345,14	346,96	325x5	24H7	315
110	348,32	350,14	328x5	24H7	317
111	351,50	353,32	331x5	24H7	321
112	354,69	356,51	334x5	24H7	323
113	357,87	359,69	337x5	24H7	327
114	361,05	362,87	341x5	24H7	330

# Timing pulleys self-tracking Profiles

## SFAT 10

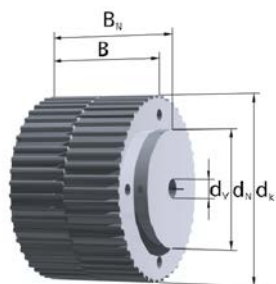

### Order example:

Pulley AL 65 SFAT 10 / 40 Hub 80x10; dv  
 Material \_\_\_\_\_  
 Total width  $B_N$  \_\_\_\_\_  
 Type / pitch \_\_\_\_\_  
 Number of teeth \_\_\_\_\_  
 Hub dimension  $d_N \times l_N$  \_\_\_\_\_

Note for part code:

dv = Diameter pre-drilled.

Refer to page 14 for further ordering information.

Belt width	b [mm]	50	75	100
Pulley width	B [mm]	55	80	105
Total width	$B_N$ [mm]	65	90	115

**Material:**  
 Pulley: AlCu4MgSi, RoHS-conformant

### Other dimensions.

- z = Number of teeth
- $d_k$  = Outside diameter
- $d_0$  = Pitch circle diameter
- $d_N$  = Hub diameter
- $l_N$  = Hub length
- $d_B$  = Flange diameter
- $d_v$  = Pre-bore diameter
- $d_{max}$  = max. bore diameter without keyway for flanged timing pulleys; no hub at maximum pre-bore

z	Hub		Bore		
	$d_k$ [mm]	$d_0$ [mm]	$d_N \times l_N$ [mm]	$d_v$ [mm]	$d_{max}$ [mm]
15	45,93	47,75	32x10	8H7	17
16	49,11	50,93	35x10	8H7	20
17	52,29	54,11	40x10	8H7	24
18	55,48	57,30	40x10	10H7	27
19	58,66	60,48	44x10	10H7	30
<hr/>					
20	61,84	63,66	46x10	12H7	33
21	65,03	66,85	46x10	12H7	36
22	68,21	70,03	50x10	12H7	40
23	71,39	73,21	50x10	12H7	43
24	74,57	76,39	58x10	12H7	46
<hr/>					
25	77,76	79,58	60x10	12H7	49
26	80,94	82,76	60x10	12H7	52
27	84,12	85,94	60x10	12H7	55
28	87,31	89,13	60x10	12H7	59
29	90,49	92,31	60x10	12H7	62

z	Hub		Bore		
	$d_k$ [mm]	$d_0$ [mm]	$d_N \times l_N$ [mm]	$d_v$ [mm]	$d_{max}$ [mm]
30	93,67	95,49	60x10	12H7	65
31	96,86	98,68	60x10	12H7	68
32	100,04	101,86	65x10	12H7	71
33	103,22	105,04	65x10	12H7	75
34	106,41	108,23	65x10	12H7	78
<hr/>					
35	109,59	111,41	65x10	12H7	81
36	112,77	114,59	70x10	16H7	84
37	115,95	117,77	70x10	16H7	87
38	119,14	120,96	70x10	16H7	90
39	122,32	124,14	70x10	16H7	94
<hr/>					
40	125,50	127,32	80x10	16H7	97
41	128,69	130,51	80x10	16H7	100
42	131,87	133,69	80x10	16H7	103
43	135,05	136,87	80x10	16H7	106
44	138,24	140,06	90x10	16H7	110



## SFAT 10

z	d <sub>k</sub> [mm]	d <sub>0</sub> [mm]	Hub	Bore	
			d <sub>N</sub> x l <sub>N</sub> [mm]	d <sub>V</sub> [mm]	d <sub>max</sub> [mm]
45	141,42	143,24	90x10	16H7	113
46	144,60	146,42	90x10	16H7	116
47	147,79	149,61	90x10	16H7	119
48	150,97	152,79	95x10	16H7	122
49	154,15	155,97	95x10	16H7	125
50	157,33	159,15	95x10	16H7	129
51	160,52	162,34	95x10	16H7	132
52	163,70	165,52	110x10	16H7	135
53	166,88	168,70	110x10	16H7	138
54	170,07	171,89	110x10	16H7	141
55	173,25	175,07	110x10	16H7	145
56	176,43	178,25	110x10	16H7	148
57	179,62	181,44	110x10	16H7	151
58	182,80	184,62	110x10	16H7	154
59	185,98	187,80	110x10	16H7	157
60	189,17	190,99	110x10	16H7	160
61	192,35	194,17	110x10	16H7	164
62	195,53	197,35	110x10	16H7	167
63	198,72	200,54	140x10	16H7	170
64	201,90	203,72	140x10	16H7	173
65	205,08	206,90	140x10	16H7	176
66	208,26	210,08	140x10	16H7	180
67	211,45	213,27	140x10	16H7	183
68	214,63	216,45	140x10	16H7	186
69	217,81	219,63	140x10	16H7	189
70	221,00	222,82	140x10	16H7	192
71	224,18	226,00	140x10	16H7	195
72	227,36	229,18	140x10	16H7	199
73	230,55	232,37	140x10	20H7	202
74	233,73	235,55	140x10	20H7	205
75	236,91	238,73	140x10	20H7	208
76	240,10	241,92	140x10	20H7	211
77	243,28	245,10	160x10	20H7	215
78	246,46	248,28	160x10	20H7	218
79	249,64	251,46	160x10	20H7	221

z	d <sub>k</sub> [mm]	d <sub>0</sub> [mm]	Hub	Bore	
			d <sub>N</sub> x l <sub>N</sub> [mm]	d <sub>V</sub> [mm]	d <sub>max</sub> [mm]
80	252,83	254,65	160x10	20H7	224
81	256,01	257,83	160x10	20H7	227
82	259,19	261,01	160x10	20H7	230
83	262,38	264,20	160x10	20H7	234
84	265,56	267,38	160x10	20H7	237
85	268,74	270,56	160x10	20H7	240
86	271,93	273,75	160x10	20H7	243
87	275,11	276,93	160x10	20H7	246
88	278,29	280,11	160x10	20H7	250
89	281,48	283,30	160x10	20H7	253
90	284,66	286,48	160x10	20H7	256
91	287,84	289,66	160x10	20H7	259
92	291,03	292,85	160x10	20H7	262
93	294,21	296,03	160x10	20H7	266
94	297,39	299,21	160x10	20H7	269
95	300,57	302,39	160x10	24H7	272
96	303,76	305,58	180x10	24H7	275
97	306,94	308,76	180x10	24H7	278
98	310,12	311,94	180x10	24H7	281
99	313,31	315,13	180x10	24H7	285
100	316,49	318,31	180x10	24H7	288
101	319,67	321,49	180x10	24H7	291
102	322,86	324,68	180x10	24H7	294
103	326,04	327,86	180x10	24H7	297
104	329,22	331,04	180x10	24H7	301
105	332,41	334,23	180x10	24H7	304
106	335,59	337,41	180x10	24H7	307
107	338,77	340,59	180x10	24H7	310
108	341,95	343,77	180x10	24H7	313
109	345,14	346,96	180x10	24H7	316
110	348,32	350,14	180x10	24H7	320
111	351,50	353,32	180x10	24H7	323
112	354,69	356,51	180x10	24H7	326
113	357,87	359,69	180x10	24H7	329
114	361,05	362,87	180x10	24H7	332

# Timing pulleys self-tracking Profiles

## SFAT 15

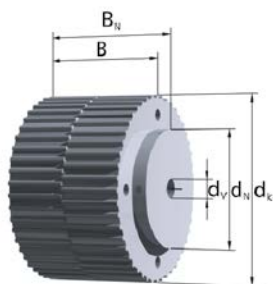

### Order example:

Pulley AL 70 SFAT 15 / 40 Hub 110x10; dv  
 Material \_\_\_\_\_  
 Total width  $B_N$  \_\_\_\_\_  
 Type / pitch \_\_\_\_\_  
 Number of teeth \_\_\_\_\_  
 Hub dimension  $d_N \times l_N$  \_\_\_\_\_

Note for part code:

dv = Diameter pre-drilled.

Refer to page 14 for further ordering information.

Belt width	b [mm]	50	75	100
Pulley width	B [mm]	55	80	105
Total width	$B_N$ [mm]	65	90	115

### Material:

Pulley: AlCu4MgSi, RoHS-conformant

### Other dimensions.

- z = Number of teeth
- $d_k$  = Outside diameter
- $d_o$  = Pitch circle diameter
- $d_N$  = Hub diameter
- $l_N$  = Hub length
- $d_B$  = Flange diameter
- $d_v$  = Pre-bore diameter
- $d_{max}$  = max. bore diameter without keyway for flanged timing pulleys; no hub at maximum pre-bore

z	Hub		Bore		
	$d_k$ [mm]	$d_o$ [mm]	$d_N \times l_N$ [mm]	$d_v$ [mm]	$d_{max}$ [mm]
20	93,01	95,49	60x10	12H7	58
21	97,79	100,27	60x10	12H7	63
22	102,56	105,04	65x10	12H7	68
23	107,34	109,82	65x10	12H7	72
24	112,11	114,59	70x10	12H7	77
25	116,89	119,37	80x10	12H7	82
26	121,66	124,14	80x10	12H7	87
27	126,44	128,92	80x10	12H7	91
28	131,21	133,69	80x10	12H7	96
29	135,98	138,46	80x10	12H7	101

z	Hub		Bore		
	$d_k$ [mm]	$d_o$ [mm]	$d_N \times l_N$ [mm]	$d_v$ [mm]	$d_{max}$ [mm]
30	140,76	143,24	90x10	12H7	106
31	145,53	148,01	90x10	12H7	111
32	150,31	152,79	95x10	12H7	115
33	155,08	157,56	95x10	16H7	120
34	159,86	162,34	95x10	16H7	125
35	164,63	167,11	95x10	16H7	130
36	169,41	171,89	100x10	16H7	134
37	174,18	176,66	100x10	16H7	139
38	178,96	181,44	100x10	16H7	144
39	183,73	186,21	100x10	16H7	149
40	188,51	190,99	110x10	16H7	154
41	193,28	195,76	110x10	16H7	158
42	198,05	200,54	110x10	16H7	163
43	202,83	205,31	110x10	16H7	168
44	207,60	210,08	110x10	16H7	173

## SFAT 15

z	d <sub>K</sub> [mm]	d <sub>0</sub> [mm]	Hub	Bore	
			d <sub>N</sub> x l <sub>N</sub> [mm]	d <sub>V</sub> [mm]	d <sub>max</sub> [mm]
45	212,38	214,86	110x10	16H7	177
46	217,15	219,63	140x10	16H7	182
47	221,93	224,41	140x10	16H7	187
48	226,70	229,18	140x10	16H7	192
49	231,48	233,96	140x10	16H7	196
50	236,25	238,73	140x10	16H7	201
51	241,03	243,51	140x10	16H7	206
52	245,80	248,28	140x10	16H7	211
53	250,58	253,06	160x10	16H7	216
54	255,35	257,83	160x10	16H7	220
55	260,13	262,61	160x10	16H7	225
56	264,90	267,38	160x10	16H7	230
57	269,67	272,15	160x10	16H7	235
58	274,45	276,93	160x10	16H7	239
59	279,22	281,70	160x10	16H7	244
60	284,00	286,48	160x10	16H7	249
61	288,77	291,25	160x10	16H7	254
62	293,55	296,03	160x10	16H7	259
63	298,32	300,80	160x10	16H7	263
64	303,10	305,58	160x10	16H7	268
65	307,87	310,35	160x10	16H7	273
66	312,65	315,13	160x10	16H7	278
67	317,42	319,90	160x10	16H7	282
68	322,20	324,68	160x10	16H7	287
69	326,97	329,45	160x10	16H7	292
70	331,74	334,23	160x10	16H7	297
71	336,52	339,00	160x10	16H7	302
72	341,29	343,77	160x10	16H7	306
73	346,07	348,55	160x10	20H7	311
74	350,84	353,32	160x10	20H7	316
75	355,62	358,10	160x10	20H7	321
76	360,39	362,87	160x10	20H7	325
77	365,17	367,65	160x10	20H7	330
78	369,94	372,42	160x10	20H7	335
79	374,72	377,20	160x10	20H7	340

z	d <sub>K</sub> [mm]	d <sub>0</sub> [mm]	Hub	Bore	
			d <sub>N</sub> x l <sub>N</sub> [mm]	d <sub>V</sub> [mm]	d <sub>max</sub> [mm]
80	379,49	381,97	160x10	20H7	344
81	384,27	386,75	160x10	20H7	349
82	389,04	391,52	160x10	20H7	354
83	393,81	396,30	160x10	20H7	359
84	398,59	401,07	160x10	20H7	364
85	403,36	405,85	200x10	20H7	368
86	408,14	410,62	200x10	20H7	373
87	412,91	415,39	200x10	20H7	378
88	417,69	420,17	200x10	20H7	383
89	422,46	424,94	200x10	20H7	387
90	427,24	429,72	200x10	20H7	392
91	432,01	434,49	200x10	20H7	397
92	436,79	439,27	200x10	20H7	402
93	441,56	444,04	200x10	20H7	407
94	446,34	448,82	200x10	20H7	411
95	451,11	453,59	200x10	20H7	416
96	455,89	458,37	200x10	20H7	421
97	460,66	463,14	200x10	30H7	426
98	465,43	467,92	200x10	30H7	430
99	470,21	472,69	200x10	30H7	435
100	474,98	477,46	200x10	30H7	440
101	479,76	482,24	200x10	30H7	445
102	484,53	487,01	200x10	30H7	450
103	489,31	491,79	200x10	30H7	454
104	494,08	496,56	200x10	30H7	459
105	498,86	501,34	200x10	30H7	464
106	503,63	506,11	200x10	30H7	469
107	508,41	510,89	200x10	30H7	473
108	513,18	515,66	200x10	30H7	478
109	517,96	520,44	200x10	30H7	483
110	522,73	525,21	200x10	30H7	488
111	527,50	529,99	200x10	30H7	493
112	532,28	534,76	200x10	30H7	497
113	537,05	539,54	200x10	30H7	502
114	541,83	544,31	200x10	30H7	507

# Timing pulleys self-tracking Profiles

## SFAT 20

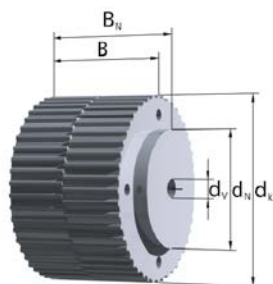

### Order example:

Pulley AL 90 SFAT 20 / 40 Hub 110x10; dv  
 Material \_\_\_\_\_  
 Total width  $B_N$  \_\_\_\_\_  
 Type / pitch \_\_\_\_\_  
 Number of teeth \_\_\_\_\_  
 Hub dimension  $d_N \times l_N$  \_\_\_\_\_

Note for part code:

dv = Diameter pre-drilled.

Refer to page 14 for further ordering information.

Belt width	b [mm]	50	75	100
Pulley width	B [mm]	55	80	105
Total width	$B_N$ [mm]	65	90	115

### Material:

Pulley: AlCu4MgSi, RoHS-conformant

### Other dimensions.

- z = Number of teeth
- $d_k$  = Outside diameter
- $d_0$  = Pitch circle diameter
- $d_N$  = Hub diameter
- $l_N$  = Hub length
- $d_B$  = Flange diameter
- $d_v$  = Pre-bore diameter
- $d_{max}$  = max. bore diameter without keyway for flanged timing pulleys; no hub at maximum pre-bore

z	Hub			Bore	
	$d_k$ [mm]	$d_0$ [mm]	$d_N \times l_N$ [mm]	$d_v$ [mm]	$d_{max}$ [mm]
18	111,77	114,59	70x10	12H7	70
19	118,14	120,96	80x10	12H7	76
20	124,50	127,32	90x10	16H7	83
21	130,87	133,69	90x10	16H7	89
22	137,24	140,06	90x10	16H7	95
23	143,60	146,42	90x10	16H7	102
24	149,97	152,79	95x10	16H7	108
25	156,33	159,15	95x10	16H7	114
26	162,70	165,52	95x10	16H7	121
27	169,07	171,89	110x10	16H7	127
28	175,43	178,25	110x10	16H7	133
29	181,80	184,62	110x10	16H7	140

z	Hub			Bore	
	$d_k$ [mm]	$d_0$ [mm]	$d_N \times l_N$ [mm]	$d_v$ [mm]	$d_{max}$ [mm]
30	188,17	190,99	110x10	16H7	146
31	194,53	197,35	110x10	16H7	153
32	200,90	203,72	110x10	16H7	159
33	207,26	210,08	110x10	16H7	165
34	213,63	216,45	110x10	16H7	172
35	220,00	222,82	110x10	16H7	178
36	226,36	229,18	110x10	18H7	184
37	232,73	235,55	110x10	18H7	191
38	239,10	241,92	110x10	18H7	197
39	245,46	248,28	110x10	18H7	203
40	251,83	254,65	110x10	18H7	210
41	258,19	261,01	130x10	18H7	216
42	264,56	267,38	130x10	18H7	223
43	270,93	273,75	130x10	18H7	229
44	277,29	280,11	130x10	18H7	235



## SFAT 20

z	d <sub>K</sub> [mm]	d <sub>0</sub> [mm]	Hub	Bore	
			d <sub>N</sub> x l <sub>N</sub> [mm]	d <sub>V</sub> [mm]	d <sub>max</sub> [mm]
45	283,66	286,48	130x10	18H7	242
46	290,03	292,85	130x10	18H7	248
47	296,39	299,21	130x10	18H7	254
48	302,76	305,58	130x10	18H7	261
49	309,12	311,94	130x10	20H7	267
50	315,49	318,31	140x10	20H7	273
51	321,86	324,68	140x10	20H7	280
52	328,22	331,04	140x10	20H7	286
53	334,59	337,41	140x10	20H7	293
54	340,95	343,77	140x10	20H7	299
55	347,32	350,14	140x10	20H7	305
56	353,69	356,51	140x10	20H7	312
57	360,05	362,87	140x10	20H7	318
58	366,42	369,24	140x10	20H7	324
59	372,79	375,61	140x10	20H7	331
60	379,15	381,97	140x10	20H7	337
61	385,52	388,34	140x10	20H7	344
62	391,88	394,70	140x10	20H7	350
63	398,25	401,07	140x10	20H7	356
64	404,62	407,44	140x10	20H7	363
65	410,98	413,80	140x10	20H7	369
66	417,35	420,17	140x10	20H7	375
67	423,72	426,54	140x10	20H7	382
68	430,08	432,90	140x10	20H7	388
69	436,45	439,27	140x10	20H7	394
70	442,81	445,63	140x10	20H7	401
71	449,18	452,00	140x10	20H7	407
72	455,55	458,37	140x10	20H7	414
73	461,91	464,73	160x10	30H7	420
74	468,28	471,10	160x10	30H7	426
75	474,64	477,46	160x10	30H7	433
76	481,01	483,83	160x10	30H7	439
77	487,38	490,20	160x10	30H7	445
78	493,74	496,56	160x10	30H7	452
79	500,11	502,93	160x10	30H7	458

z	d <sub>K</sub> [mm]	d <sub>0</sub> [mm]	Hub	Bore	
			d <sub>N</sub> x l <sub>N</sub> [mm]	d <sub>V</sub> [mm]	d <sub>max</sub> [mm]
80	506,48	509,30	-	30H7	464
81	512,84	515,66	-	30H7	471
82	519,21	522,03	-	30H7	477
83	525,57	528,39	-	30H7	484
84	531,94	534,76	-	30H7	490
85	538,31	541,13	-	30H7	496
86	544,67	547,49	-	30H7	503
87	551,04	553,86	-	30H7	509
88	557,41	560,23	-	30H7	515
89	563,77	566,59	-	30H7	522
90	570,14	572,96	-	30H7	528
91	576,50	579,32	-	30H7	535
92	582,87	585,69	-	30H7	541
93	589,24	592,06	-	30H7	547
94	595,60	598,42	-	30H7	554
95	601,97	604,79	-	40H7	560
96	608,33	611,15	-	40H7	566
97	614,70	617,52	-	40H7	573
98	621,07	623,89	-	40H7	579
99	627,43	630,25	-	40H7	585
100	633,80	636,62	-	40H7	592
101	640,17	642,99	-	40H7	598
102	646,53	649,35	-	40H7	605
103	652,90	655,72	-	40H7	611
104	659,26	662,08	-	40H7	617
105	665,63	668,45	-	40H7	624
106	672,00	674,82	-	40H7	630
107	678,36	681,18	-	40H7	636
108	684,73	687,55	-	40H7	643
109	691,10	693,92	-	40H7	649
110	697,46	700,28	-	40H7	655
111	703,83	706,65	-	40H7	662
112	710,19	713,01	-	40H7	668
113	716,56	719,38	-	40H7	675
114	722,93	725,75	-	40H7	681

# Timing pulleys self-tracking Profiles

## Self-tracking pulleys ATK 5 K6

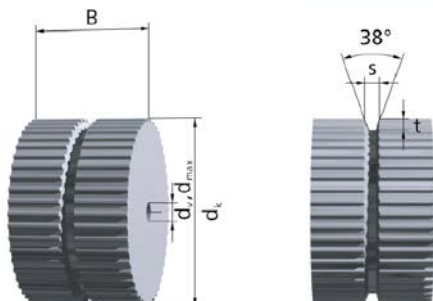

### Order example:

Self-tracking pulley Al 55 ATK 5 K6 / 32 d = 15H7  
 Material \_\_\_\_\_  
 Width B \_\_\_\_\_  
 Type / pitch \_\_\_\_\_  
 Number of teeth \_\_\_\_\_  
 Bore \_\_\_\_\_

Refer to page 14 for further ordering information.

Belt width	b [mm]	32	50	75
Pulley width	B [mm]	37	55	80

### Material:

AlCu4MgSi, RoHS-conformant

Intermediate and larger widths possible.

- z = Number of teeth
- d<sub>k</sub> = Outside diameter
- d<sub>0</sub> = Pitch circle diameter
- s = Groove width
- t = Groove depth
- d<sub>v</sub> = Pre-bore diameter
- d<sub>max</sub> = max. bore diameter without keyway for flanged timing pulleys

z	d <sub>k</sub> [mm]	d <sub>0</sub> [mm]	s [mm]	t [mm]	Bore	
					d <sub>v</sub> [mm]	d <sub>max</sub> [mm]
20	30,61	31,83	6,5	5	6H7	11
21	32,20	33,42	6,5	5	6H7	12
22	33,79	35,01	6,5	5	8H7	14
23	35,39	36,61	6,5	5	8H7	15
24	36,98	38,20	6,5	5	8H7	17
25	38,57	39,79	6,5	5	8H7	19
26	40,16	41,38	6,5	5	8H7	20
27	41,75	42,97	6,5	5	8H7	22
28	43,34	44,56	6,5	5	8H7	23
29	44,93	46,15	6,5	5	8H7	25

z	d <sub>k</sub> [mm]	d <sub>0</sub> [mm]	s [mm]	t [mm]	Bore	
					d <sub>v</sub> [mm]	d <sub>max</sub> [mm]
30	46,53	47,75	6,5	5	8H7	27
31	48,12	49,34	6,5	5	8H7	28
32	49,71	50,93	6,5	5	8H7	30
33	51,30	52,52	6,5	5	8H7	31
34	52,89	54,11	6,5	5	8H7	33
35	54,48	55,70	6,5	5	8H7	34
36	56,08	57,30	6,5	5	8H7	36
37	57,67	58,89	6,5	5	8H7	38
38	59,26	60,48	6,5	5	8H7	39
39	60,85	62,07	6,5	5	8H7	41
40	62,44	63,66	6,5	5	12H7	42
41	64,03	65,25	6,5	5	12H7	44
42	65,63	66,85	6,5	5	12H7	46
43	67,22	68,44	6,5	5	12H7	47
44	68,81	70,03	6,5	5	12H7	49

## Self-tracking pulleys ATK 5 K6

z	d <sub>k</sub> [mm]	d <sub>0</sub> [mm]	s [mm]	t [mm]	Bore	
					d <sub>v</sub> [mm]	d <sub>max</sub> [mm]
45	70,40	71,62	6,5	5	12H7	50
46	71,99	73,21	6,5	5	12H7	52
47	73,58	74,80	6,5	5	12H7	54
48	75,17	76,39	6,5	5	12H7	55
49	76,77	77,99	6,5	5	12H7	57
50	78,36	79,58	6,5	5	12H7	58
51	79,95	81,17	6,5	5	12H7	60
52	81,54	82,76	6,5	5	12H7	62
53	83,13	84,35	6,5	5	12H7	63
54	84,72	85,94	6,5	5	12H7	65
55	86,32	87,54	6,5	5	12H7	66
56	87,91	89,13	6,5	5	12H7	68
57	89,50	90,72	6,5	5	12H7	69
58	91,09	92,31	6,5	5	12H7	71
59	92,68	93,90	6,5	5	12H7	73
60	94,27	95,49	6,5	5	12H7	74
61	95,86	97,08	6,5	5	12H7	76
62	97,46	98,68	6,5	5	12H7	77
63	99,05	100,27	6,5	5	12H7	79
64	100,64	101,86	6,5	5	12H7	81
65	102,23	103,45	6,5	5	12H7	82
66	103,82	105,04	6,5	5	12H7	84
67	105,41	106,63	6,5	5	12H7	85
68	107,01	108,23	6,5	5	12H7	87
69	108,60	109,82	6,5	5	12H7	89
70	110,19	111,41	6,5	5	12H7	90
71	111,78	113,00	6,5	5	12H7	92
72	113,37	114,59	6,5	5	12H7	93
73	114,96	116,18	6,5	5	12H7	95
74	116,55	117,77	6,5	5	12H7	97
75	118,15	119,37	6,5	5	12H7	98
76	119,74	120,96	6,5	5	12H7	100
77	121,33	122,55	6,5	5	12H7	101
78	122,92	124,14	6,5	5	12H7	103
79	124,51	125,73	6,5	5	12H7	105

z	d <sub>k</sub> [mm]	d <sub>0</sub> [mm]	s [mm]	t [mm]	Bore	
					d <sub>v</sub> [mm]	d <sub>max</sub> [mm]
80	126,10	127,32	6,5	5	12H7	106
81	127,70	128,92	6,5	5	12H7	108
82	129,29	130,51	6,5	5	12H7	109
83	130,88	132,10	6,5	5	12H7	111
84	132,47	133,69	6,5	5	12H7	112
85	134,06	135,28	6,5	5	12H7	114
86	135,65	136,87	6,5	5	12H7	116
87	137,24	138,46	6,5	5	12H7	117
88	138,84	140,06	6,5	5	12H7	119
89	140,43	141,65	6,5	5	12H7	120
90	142,02	143,24	6,5	5	12H7	122
91	143,61	144,83	6,5	5	12H7	124
92	145,20	146,42	6,5	5	12H7	125
93	146,79	148,01	6,5	5	12H7	127
94	148,39	149,61	6,5	5	12H7	128
95	149,98	151,20	6,5	5	12H7	130
96	151,57	152,79	6,5	5	12H7	132
97	153,16	154,38	6,5	5	12H7	133
98	154,75	155,97	6,5	5	12H7	135
99	156,34	157,56	6,5	5	12H7	136
100	157,93	159,15	6,5	5	12H7	138
101	159,53	160,75	6,5	5	12H7	140
102	161,12	162,34	6,5	5	12H7	141
103	162,71	163,93	6,5	5	12H7	143
104	164,30	165,52	6,5	5	12H7	144
105	165,89	167,11	6,5	5	12H7	146
106	167,48	168,70	6,5	5	12H7	147
107	169,08	170,30	6,5	5	12H7	149
108	170,67	171,89	6,5	5	12H7	151
109	172,26	173,48	6,5	5	12H7	152
110	173,85	175,07	6,5	5	12H7	154
111	175,44	176,66	6,5	5	12H7	155
112	177,03	178,25	6,5	5	12H7	157
113	178,63	179,85	6,5	5	12H7	159
114	180,22	181,44	6,5	5	12H7	160

# Timing pulleys self-tracking Profiles

## Self-tracking pulleys ATK 10 K13

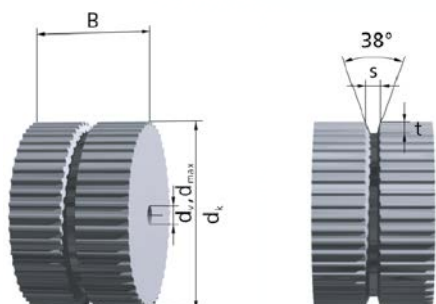

**Order example:**

Self-tracking pulley **Al 55 ATK 10 K13 / 32 d = 15H7**

Material \_\_\_\_\_

Width B \_\_\_\_\_

Type / pitch \_\_\_\_\_

Number of teeth \_\_\_\_\_

Bore \_\_\_\_\_

Refer to page 14 for further ordering information.

Belt width	b [mm]	32	50	75	100	150
Pulley width	B [mm]	40	55	80	105	155

**Material:**  
AlCu4MgSi, RoHS-conformant

Intermediate and larger widths possible.

- z = Number of teeth
- d<sub>k</sub> = Outside diameter
- d<sub>0</sub> = Pitch circle diameter
- s = Groove width
- t = Groove depth
- d<sub>v</sub> = Pre-bore diameter
- d<sub>max</sub> = max. bore diameter without keyway for flanged timing pulleys

z	d <sub>k</sub> [mm]	d <sub>0</sub> [mm]	s [mm]	t [mm]	Bore	
					d <sub>v</sub> [mm]	d <sub>max</sub> [mm]
20	61,84	63,66	13,5	7,5	12H7	37
21	65,03	66,85	13,5	7,5	12H7	40
22	68,21	70,03	13,5	7,5	12H7	43
23	71,39	73,21	13,5	7,5	12H7	46
24	74,57	76,39	13,5	7,5	12H7	50
25	77,76	79,58	13,5	7,5	12H7	52
26	80,94	82,76	13,5	7,5	12H7	56
27	84,12	85,94	13,5	7,5	12H7	59
28	87,31	89,13	13,5	7,5	12H7	62
29	90,49	92,31	13,5	7,5	12H7	65

z	d <sub>k</sub> [mm]	d <sub>0</sub> [mm]	s [mm]	t [mm]	Bore	
					d <sub>v</sub> [mm]	d <sub>max</sub> [mm]
30	93,67	95,49	13,5	7,5	12H7	69
31	96,86	98,68	13,5	7,5	12H7	72
32	100,04	101,86	13,5	7,5	12H7	75
33	103,22	105,04	13,5	7,5	12H7	78
34	106,41	108,23	13,5	7,5	12H7	81
35	109,59	111,41	13,5	7,5	12H7	85
36	112,77	114,59	13,5	7,5	16H7	88
37	115,95	117,77	13,5	7,5	16H7	91
38	119,14	120,96	13,5	7,5	16H7	94
39	122,32	124,14	13,5	7,5	16H7	97
40	125,50	127,32	13,5	7,5	16H7	101
41	128,69	130,51	13,5	7,5	16H7	104
42	131,87	133,69	13,5	7,5	16H7	107
43	135,05	136,87	13,5	7,5	16H7	110
44	138,24	140,06	13,5	7,5	16H7	113



## Self-tracking pulleys ATK 10 K13

z	d <sub>k</sub> [mm]	d <sub>0</sub> [mm]	s [mm]	t [mm]	Bore	
					d <sub>v</sub> [mm]	d <sub>max</sub> [mm]
45	141,42	143,24	13,5	7,5	16H7	116
46	144,60	146,42	13,5	7,5	16H7	120
47	147,79	149,61	13,5	7,5	16H7	123
48	150,97	152,79	13,5	7,5	16H7	126
49	154,15	155,97	13,5	7,5	16H7	129
50	157,33	159,15	13,5	7,5	16H7	132
51	160,52	162,34	13,5	7,5	16H7	136
52	163,70	165,52	13,5	7,5	16H7	139
53	166,88	168,70	13,5	7,5	16H7	142
54	170,07	171,89	13,5	7,5	16H7	145
55	173,25	175,07	13,5	7,5	16H7	148
56	176,43	178,25	13,5	7,5	16H7	151
57	179,62	181,44	13,5	7,5	16H7	155
58	182,80	184,62	13,5	7,5	16H7	158
59	185,98	187,80	13,5	7,5	16H7	161
60	189,17	190,99	13,5	7,5	16H7	164
61	192,35	194,17	13,5	7,5	16H7	167
62	195,53	197,35	13,5	7,5	16H7	171
63	198,72	200,54	13,5	7,5	16H7	174
64	201,90	203,72	13,5	7,5	16H7	177
65	205,08	206,90	13,5	7,5	16H7	180
66	208,26	210,08	13,5	7,5	16H7	183
67	211,45	213,27	13,5	7,5	16H7	186
68	214,63	216,45	13,5	7,5	16H7	190
69	217,81	219,63	13,5	7,5	16H7	193
70	221,00	222,82	13,5	7,5	16H7	196
71	224,18	226,00	13,5	7,5	16H7	199
72	227,36	229,18	13,5	7,5	16H7	202
73	230,55	232,37	13,5	7,5	20H7	206
74	233,73	235,55	13,5	7,5	20H7	209
75	236,91	238,73	13,5	7,5	20H7	212
76	240,10	241,92	13,5	7,5	20H7	215
77	243,28	245,10	13,5	7,5	20H7	219
78	246,46	248,28	13,5	7,5	20H7	221
79	249,64	251,46	13,5	7,5	20H7	225

z	d <sub>k</sub> [mm]	d <sub>0</sub> [mm]	s [mm]	t [mm]	Bore	
					d <sub>v</sub> [mm]	d <sub>max</sub> [mm]
80	252,83	254,65	13,5	7,5	20H7	228
81	256,01	257,83	13,5	7,5	20H7	231
82	259,19	261,01	13,5	7,5	20H7	234
83	262,38	264,20	13,5	7,5	20H7	237
84	265,56	267,38	13,5	7,5	20H7	241
85	268,74	270,56	13,5	7,5	20H7	244
86	271,93	273,75	13,5	7,5	20H7	247
87	275,11	276,93	13,5	7,5	20H7	250
88	278,29	280,11	13,5	7,5	20H7	253
89	281,48	283,30	13,5	7,5	20H7	256
90	284,66	286,48	13,5	7,5	20H7	260
91	287,84	289,66	13,5	7,5	20H7	263
92	291,03	292,85	13,5	7,5	20H7	266
93	294,21	296,03	13,5	7,5	20H7	269
94	297,39	299,21	13,5	7,5	20H7	272
95	300,57	302,39	13,5	7,5	24H7	276
96	303,76	305,58	13,5	7,5	24H7	279
97	306,94	308,76	13,5	7,5	24H7	282
98	310,12	311,94	13,5	7,5	24H7	285
99	313,31	315,13	13,5	7,5	24H7	288
100	316,49	318,31	13,5	7,5	24H7	291
101	319,67	321,49	13,5	7,5	24H7	295
102	322,86	324,68	13,5	7,5	24H7	298
103	326,04	327,86	13,5	7,5	24H7	301
104	329,22	331,04	13,5	7,5	24H7	304
105	332,41	334,23	13,5	7,5	24H7	307
106	335,59	337,41	13,5	7,5	24H7	311
107	338,77	340,59	13,5	7,5	24H7	314
108	341,95	343,77	13,5	7,5	24H7	317
109	345,14	346,96	13,5	7,5	24H7	320
110	348,32	350,14	13,5	7,5	24H7	323
111	351,50	353,32	13,5	7,5	24H7	327
112	354,69	356,51	13,5	7,5	24H7	330
113	357,87	359,69	13,5	7,5	24H7	333
114	361,05	362,87	13,5	7,5	24H7	336

# Timing pulleys self-tracking Profiles

## Self-tracking pulleys ATK 10 K6

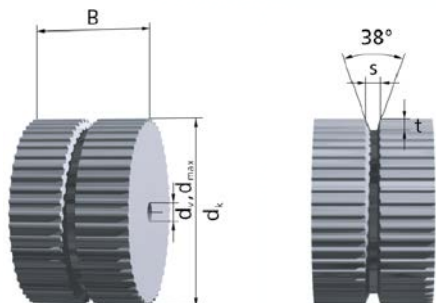

**Order example:**

Self-tracking pulley **Al 55 ATK 10 K6 / 32 d = 15H7**

Material \_\_\_\_\_

Width B \_\_\_\_\_

Type / pitch \_\_\_\_\_

Number of teeth \_\_\_\_\_

Bore \_\_\_\_\_

Refer to page 14 for further ordering information.

Belt width	b [mm]	50	100
Pulley width	B [mm]	55	105

**Material:**  
AlCu4MgSi, RoHS-conformant

Intermediate and larger widths possible.

- z = Number of teeth
- d<sub>k</sub> = Outside diameter
- d<sub>0</sub> = Pitch circle diameter
- s = Groove width
- t = Groove depth
- d<sub>v</sub> = Pre-bore diameter
- d<sub>max</sub> = max. bore diameter without keyway for flanged timing pulleys

z	d <sub>k</sub> [mm]	d <sub>0</sub> [mm]	s [mm]	t [mm]	Bore	
					d <sub>v</sub> [mm]	d <sub>max</sub> [mm]
20	61,84	63,66	6,5	5	12H7	42
21	65,03	66,85	6,5	5	12H7	45
22	68,21	70,03	6,5	5	12H7	48
23	71,39	73,21	6,5	5	12H7	51
24	74,57	76,39	6,5	5	12H7	55
25	77,76	79,58	6,5	5	12H7	56
26	80,94	82,76	6,5	5	12H7	61
27	84,12	85,94	6,5	5	12H7	64
28	87,31	89,13	6,5	5	12H7	67
29	90,49	92,31	6,5	5	12H7	70

z	d <sub>k</sub> [mm]	d <sub>0</sub> [mm]	s [mm]	t [mm]	Bore	
					d <sub>v</sub> [mm]	d <sub>max</sub> [mm]
30	93,67	95,49	6,5	5	12H7	74
31	96,86	98,68	6,5	5	12H7	77
32	100,04	101,86	6,5	5	12H7	80
33	103,22	105,04	6,5	5	12H7	83
34	106,41	108,23	6,5	5	12H7	86
35	109,59	111,41	6,5	5	12H7	90
36	112,77	114,59	6,5	5	16H7	93
37	115,95	117,77	6,5	5	16H7	96
38	119,14	120,96	6,5	5	16H7	99
39	122,32	124,14	6,5	5	16H7	102
40	125,50	127,32	6,5	5	16H7	106
41	128,69	130,51	6,5	5	16H7	109
42	131,87	133,69	6,5	5	16H7	112
43	135,05	136,87	6,5	5	16H7	115
44	138,24	140,06	6,5	5	16H7	118

## Self-tracking pulleys ATK 10 K6

z	d <sub>k</sub> [mm]	d <sub>0</sub> [mm]	s [mm]	t [mm]	Bore	
					d <sub>v</sub> [mm]	d <sub>max</sub> [mm]
45	141,42	143,24	6,5	5	16H7	121
46	144,60	146,42	6,5	5	16H7	125
47	147,79	149,61	6,5	5	16H7	128
48	150,97	152,79	6,5	5	16H7	131
49	154,15	155,97	6,5	5	16H7	134
50	157,33	159,15	6,5	5	16H7	137
51	160,52	162,34	6,5	5	16H7	141
52	163,70	165,52	6,5	5	16H7	144
53	166,88	168,70	6,5	5	16H7	147
54	170,07	171,89	6,5	5	16H7	150
55	173,25	175,07	6,5	5	16H7	153
56	176,43	178,25	6,5	5	16H7	156
57	179,62	181,44	6,5	5	16H7	160
58	182,80	184,62	6,5	5	16H7	163
59	185,98	187,80	6,5	5	16H7	166
60	189,17	190,99	6,5	5	16H7	169
61	192,35	194,17	6,5	5	16H7	172
62	195,53	197,35	6,5	5	16H7	176
63	198,72	200,54	6,5	5	16H7	179
64	201,90	203,72	6,5	5	16H7	182
65	205,08	206,90	6,5	5	16H7	185
66	208,26	210,08	6,5	5	16H7	188
67	211,45	213,27	6,5	5	16H7	191
68	214,63	216,45	6,5	5	16H7	195
69	217,81	219,63	6,5	5	16H7	198
70	221,00	222,82	6,5	5	16H7	201
71	224,18	226,00	6,5	5	16H7	204
72	227,36	229,18	6,5	5	20H7	207
73	230,55	232,37	6,5	5	20H7	211
74	233,73	235,55	6,5	5	20H7	214
75	236,91	238,73	6,5	5	20H7	217
76	240,10	241,92	6,5	5	20H7	220
77	243,28	245,10	6,5	5	20H7	223
78	246,46	248,28	6,5	5	20H7	226
79	249,64	251,46	6,5	5	20H7	230

z	d <sub>k</sub> [mm]	d <sub>0</sub> [mm]	s [mm]	t [mm]	Bore	
					d <sub>v</sub> [mm]	d <sub>max</sub> [mm]
80	252,83	254,65	6,5	5	20H7	233
81	256,01	257,83	6,5	5	20H7	236
82	259,19	261,01	6,5	5	20H7	239
83	262,38	264,20	6,5	5	20H7	242
84	265,56	267,38	6,5	5	20H7	246
85	268,74	270,56	6,5	5	20H7	249
86	271,93	273,75	6,5	5	20H7	252
87	275,11	276,93	6,5	5	20H7	255
88	278,29	280,11	6,5	5	20H7	258
89	281,48	283,30	6,5	5	20H7	261
90	284,66	286,48	6,5	5	20H7	265
91	287,84	289,66	6,5	5	20H7	268
92	291,03	292,85	6,5	5	20H7	271
93	294,21	296,03	6,5	5	20H7	274
94	297,39	299,21	6,5	5	20H7	277
95	300,57	302,39	6,5	5	24H7	281
96	303,76	305,58	6,5	5	24H7	284
97	306,94	308,76	6,5	5	24H7	287
98	310,12	311,94	6,5	5	24H7	290
99	313,31	315,13	6,5	5	24H7	293
100	316,49	318,31	6,5	5	24H7	296
101	319,67	321,49	6,5	5	24H7	300
102	322,86	324,68	6,5	5	24H7	303
103	326,04	327,86	6,5	5	24H7	306
104	329,22	331,04	6,5	5	24H7	309
105	332,41	334,23	6,5	5	24H7	312
106	335,59	337,41	6,5	5	24H7	316
107	338,77	340,59	6,5	5	24H7	319
108	341,95	343,77	6,5	5	24H7	322
109	345,14	346,96	6,5	5	24H7	325
110	348,32	350,14	6,5	5	24H7	328
111	351,50	353,32	6,5	5	24H7	332
112	354,69	356,51	6,5	5	24H7	335
113	357,87	359,69	6,5	5	24H7	338
114	361,05	362,87	6,5	5	24H7	341

# Timing pulleys self-tracking Profiles

## Self-tracking pulleys ATK 20 K13

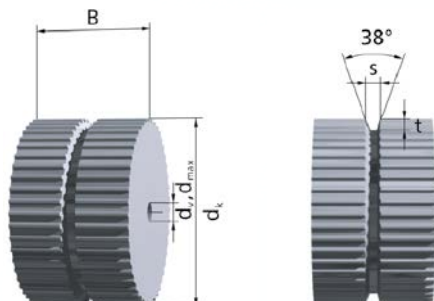

**Order example:**

Self-tracking pulley **Al 55 ATK 20 K13 / 32 d = 15H7**

Material \_\_\_\_\_

Width B \_\_\_\_\_

Type / pitch \_\_\_\_\_

Number of teeth \_\_\_\_\_

Bore \_\_\_\_\_

Refer to page 14 for further ordering information.

Belt width	b [mm]	75	100
Pulley width	B [mm]	80	105

**Material:**  
AlCu4MgSi, RoHS-conformant

Intermediate and larger widths possible.

- z = Number of teeth
- d<sub>k</sub> = Outside diameter
- d<sub>0</sub> = Pitch circle diameter
- s = Groove width
- t = Groove depth
- d<sub>v</sub> = Pre-bore diameter
- d<sub>max</sub> = max. bore diameter without keyway for flanged timing pulleys

z	d <sub>k</sub> [mm]	d <sub>0</sub> [mm]	s [mm]	t [mm]	Bore	
					d <sub>v</sub> [mm]	d <sub>max</sub> [mm]
20	124,50	127,32	13,5	7,5	16H7	94
21	130,87	133,69	13,5	7,5	16H7	100
22	137,24	140,06	13,5	7,5	16H7	107
23	143,60	146,42	13,5	7,5	16H7	113
24	149,97	152,79	13,5	7,5	16H7	119
25	156,33	159,15	13,5	7,5	16H7	126
26	162,70	165,52	13,5	7,5	16H7	132
27	169,07	171,89	13,5	7,5	16H7	139
28	175,43	178,25	13,5	7,5	16H7	145
29	181,80	184,62	13,5	7,5	16H7	151

z	d <sub>k</sub> [mm]	d <sub>0</sub> [mm]	s [mm]	t [mm]	Bore	
					d <sub>v</sub> [mm]	d <sub>max</sub> [mm]
30	188,17	190,99	13,5	7,5	16H7	158
31	194,53	197,35	13,5	7,5	16H7	164
32	200,90	203,72	13,5	7,5	16H7	170
33	207,26	210,08	13,5	7,5	16H7	177
34	213,63	216,45	13,5	7,5	16H7	183
35	220,00	222,82	13,5	7,5	16H7	190
36	226,36	229,18	13,5	7,5	18H7	196
37	232,73	235,55	13,5	7,5	18H7	202
38	239,10	241,92	13,5	7,5	18H7	209
39	245,46	248,28	13,5	7,5	18H7	215
40	251,83	254,65	13,5	7,5	18H7	221
41	258,19	261,01	13,5	7,5	18H7	228
42	264,56	267,38	13,5	7,5	18H7	234
43	270,93	273,75	13,5	7,5	18H7	240
44	277,29	280,11	13,5	7,5	18H7	247



## Self-tracking pulleys ATK 20 K13

z	d <sub>k</sub> [mm]	d <sub>0</sub> [mm]	s [mm]	t [mm]	Bore	
					d <sub>v</sub> [mm]	d <sub>max</sub> [mm]
45	283,66	286,48	13,5	7,5	18H7	253
46	290,03	292,85	13,5	7,5	18H7	260
47	296,39	299,21	13,5	7,5	18H7	266
48	302,76	305,58	13,5	7,5	18H7	272
49	309,12	311,94	13,5	7,5	20H7	279
50	315,49	318,31	13,5	7,5	20H7	285
51	321,86	324,68	13,5	7,5	20H7	292
52	328,22	331,04	13,5	7,5	20H7	298
53	334,59	337,41	13,5	7,5	20H7	304
54	340,95	343,77	13,5	7,5	20H7	310
55	347,32	350,14	13,5	7,5	20H7	317
56	353,69	356,51	13,5	7,5	20H7	323
57	360,05	362,87	13,5	7,5	20H7	330
58	366,42	369,24	13,5	7,5	20H7	336
59	372,79	375,61	13,5	7,5	20H7	342
60	379,15	381,97	13,5	7,5	20H7	349
61	385,52	388,34	13,5	7,5	20H7	355
62	391,88	394,70	13,5	7,5	20H7	362
63	398,25	401,07	13,5	7,5	20H7	368
64	404,62	407,44	13,5	7,5	20H7	374
65	410,98	413,80	13,5	7,5	20H7	380
66	417,35	420,17	13,5	7,5	20H7	387
67	423,72	426,54	13,5	7,5	20H7	393
68	430,08	432,90	13,5	7,5	20H7	400
69	436,45	439,27	13,5	7,5	20H7	406
70	442,81	445,63	13,5	7,5	20H7	412
71	449,18	452,00	13,5	7,5	20H7	419
72	455,55	458,37	13,5	7,5	20H7	425
73	461,91	464,73	13,5	7,5	30H7	431
74	468,28	471,10	13,5	7,5	30H7	438
75	474,64	477,46	13,5	7,5	30H7	444
76	481,01	483,83	13,5	7,5	30H7	451
77	487,38	490,20	13,5	7,5	30H7	457
78	493,74	496,56	13,5	7,5	30H7	463
79	500,11	502,93	13,5	7,5	30H7	470

z	d <sub>k</sub> [mm]	d <sub>0</sub> [mm]	s [mm]	t [mm]	Bore	
					d <sub>v</sub> [mm]	d <sub>max</sub> [mm]
80	506,48	509,30	13,5	7,5	30H7	476
81	512,84	515,66	13,5	7,5	30H7	482
82	519,21	522,03	13,5	7,5	30H7	489
83	525,57	528,39	13,5	7,5	30H7	495
84	531,94	534,76	13,5	7,5	30H7	500
85	538,31	541,13	13,5	7,5	30H7	500
86	544,67	547,49	13,5	7,5	30H7	504
87	551,04	553,86	13,5	7,5	30H7	511
88	557,41	560,23	13,5	7,5	30H7	517
89	563,77	566,59	13,5	7,5	30H7	523
90	570,14	572,96	13,5	7,5	30H7	530
91	576,50	579,32	13,5	7,5	30H7	536
92	582,87	585,69	13,5	7,5	30H7	542
93	589,24	592,06	13,5	7,5	30H7	549
94	595,60	598,42	13,5	7,5	30H7	555
95	601,97	604,79	13,5	7,5	40H7	562
96	608,33	611,15	13,5	7,5	40H7	568
97	614,70	617,52	13,5	7,5	40H7	574
98	621,07	623,89	13,5	7,5	40H7	581
99	627,43	630,25	13,5	7,5	40H7	587
100	633,80	636,62	13,5	7,5	40H7	593
101	640,17	642,99	13,5	7,5	40H7	600
102	646,53	649,35	13,5	7,5	40H7	606
103	652,90	655,72	13,5	7,5	40H7	612
104	659,26	662,08	13,5	7,5	40H7	619
105	665,63	668,45	13,5	7,5	40H7	625
106	672,00	674,82	13,5	7,5	40H7	632
107	678,36	681,18	13,5	7,5	40H7	638
108	684,73	687,55	13,5	7,5	40H7	644
109	691,10	693,92	13,5	7,5	40H7	651
110	697,46	700,28	13,5	7,5	40H7	659
111	703,83	706,65	13,5	7,5	40H7	663
112	710,19	713,01	13,5	7,5	40H7	670
113	716,56	719,38	13,5	7,5	40H7	676
114	722,93	725,75	13,5	7,5	40H7	682

# Timing pulleys self-tracking Profiles

## Self-tracking pulleys TK 5 K6

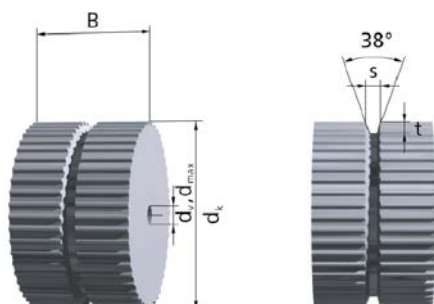

### Order example:

Self-tracking pulley **Al 55 TK 5 K6 / 32 d = 15H7**

Material \_\_\_\_\_

Width B \_\_\_\_\_

Type / pitch \_\_\_\_\_

Number of teeth \_\_\_\_\_

Bore \_\_\_\_\_

Refer to page 14 for further ordering information.

Belt width	b [mm]	32	50
Pulley width	B [mm]	37	55

**Material:**  
AlCu4MgSi, RoHS-conformant

Intermediate and larger widths possible.

- z = Number of teeth
- d<sub>k</sub> = Outside diameter
- d<sub>0</sub> = Pitch circle diameter
- s = Groove width
- t = Groove depth
- d<sub>v</sub> = Pre-bore diameter
- d<sub>max</sub> = max. bore diameter without keyway for flanged timing pulleys

z	d <sub>k</sub> [mm]	d <sub>0</sub> [mm]	s [mm]	t [mm]	Bore	
					d <sub>v</sub> [mm]	d <sub>max</sub> [mm]
20	31,00	31,83	6,5	5	6H7	11
21	32,60	33,42	6,5	5	6H7	13
22	34,15	35,01	6,5	5	8H7	14
23	35,75	36,61	6,5	5	8H7	16
24	37,35	38,20	6,5	5	8H7	17
25	38,95	39,79	6,5	5	8H7	19
26	40,55	41,38	6,5	5	8H7	21
27	42,15	42,97	6,5	5	8H7	22
28	43,75	44,56	6,5	5	8H7	24
29	45,30	46,15	6,5	5	8H7	25

z	d <sub>k</sub> [mm]	d <sub>0</sub> [mm]	s [mm]	t [mm]	Bore	
					d <sub>v</sub> [mm]	d <sub>max</sub> [mm]
30	46,90	47,75	6,5	5	8H7	27
31	48,50	49,34	6,5	5	8H7	29
32	50,10	50,93	6,5	5	8H7	30
33	51,70	52,52	6,5	5	8H7	32
34	53,30	54,11	6,5	5	8H7	33
35	54,85	55,70	6,5	5	8H7	35
36	56,45	57,30	6,5	5	8H7	36
37	58,05	58,89	6,5	5	8H7	38
38	59,65	60,48	6,5	5	8H7	40
39	61,25	62,07	6,5	5	8H7	41
40	62,85	63,66	6,5	5	12H7	43
41	64,40	65,25	6,5	5	12H7	44
42	66,00	66,85	6,5	5	12H7	46
43	67,60	68,44	6,5	5	12H7	48
44	69,20	70,03	6,5	5	12H7	49

## Self-tracking pulleys TK 5 K6

z	d <sub>k</sub> [mm]	d <sub>0</sub> [mm]	s [mm]	t [mm]	Bore	
					d <sub>v</sub> [mm]	d <sub>max</sub> [mm]
45	70,80	71,62	6,5	5	12H7	51
46	72,40	73,21	6,5	5	12H7	52
47	73,95	74,80	6,5	5	12H7	54
48	75,55	76,39	6,5	5	12H7	56
49	77,15	77,99	6,5	5	12H7	57
50	78,75	79,58	6,5	5	12H7	59
51	80,35	81,17	6,5	5	12H7	60
52	81,95	82,76	6,5	5	12H7	62
53	83,55	84,35	6,5	5	12H7	64
54	85,10	85,94	6,5	5	12H7	65
55	86,70	87,54	6,5	5	12H7	67
56	88,30	89,13	6,5	5	12H7	68
57	89,90	90,72	6,5	5	12H7	70
58	91,50	92,31	6,5	5	12H7	72
59	93,10	93,90	6,5	5	12H7	73
60	94,65	95,49	6,5	5	12H7	75
61	96,25	97,08	6,5	5	12H7	76
62	97,85	98,68	6,5	5	12H7	78
63	99,45	100,27	6,5	5	12H7	80
64	101,05	101,86	6,5	5	12H7	81
65	102,65	103,45	6,5	5	12H7	83
66	104,20	105,04	6,5	5	12H7	84
67	105,80	106,63	6,5	5	12H7	86
68	107,40	108,23	6,5	5	12H7	87
69	109,00	109,82	6,5	5	12H7	89
70	110,60	111,41	6,5	5	12H7	91
71	112,20	113,00	6,5	5	12H7	92
72	113,75	114,59	6,5	5	12H7	94
73	115,35	116,18	6,5	5	12H7	95
74	116,95	117,77	6,5	5	12H7	97
75	118,55	119,37	6,5	5	12H7	99
76	120,15	120,96	6,5	5	12H7	100
77	121,75	122,55	6,5	5	12H7	102
78	123,35	124,14	6,5	5	12H7	103
79	124,90	125,73	6,5	5	12H7	105

z	d <sub>k</sub> [mm]	d <sub>0</sub> [mm]	s [mm]	t [mm]	Bore	
					d <sub>v</sub> [mm]	d <sub>max</sub> [mm]
80	126,50	127,32	6,5	5	12H7	107
81	128,10	128,92	6,5	5	12H7	108
82	129,70	130,51	6,5	5	12H7	110
83	131,30	132,10	6,5	5	12H7	111
84	132,90	133,69	6,5	5	12H7	113
85	134,45	135,28	6,5	5	12H7	114
86	136,05	136,87	6,5	5	12H7	116
87	137,65	138,46	6,5	5	12H7	118
88	139,25	140,06	6,5	5	12H7	119
89	140,85	141,65	6,5	5	12H7	121
90	142,45	143,24	6,5	5	12H7	122
91	144,00	144,83	6,5	5	12H7	124
92	145,60	146,42	6,5	5	12H7	126
93	147,20	148,01	6,5	5	12H7	127
94	148,80	149,61	6,5	5	12H7	129
95	150,40	151,20	6,5	5	12H7	130
96	152,00	152,79	6,5	5	12H7	132
97	153,55	154,38	6,5	5	12H7	134
98	155,15	155,97	6,5	5	12H7	135
99	156,75	157,56	6,5	5	12H7	137
100	158,35	159,15	6,5	5	12H7	138
101	159,95	160,75	6,5	5	12H7	140
102	161,55	162,34	6,5	5	12H7	142
103	163,15	163,93	6,5	5	12H7	143
104	164,70	165,52	6,5	5	12H7	145
105	166,30	167,11	6,5	5	12H7	146
106	167,90	168,70	6,5	5	12H7	148
107	169,50	170,30	6,5	5	12H7	150
108	171,10	171,89	6,5	5	12H7	151
109	172,70	173,48	6,5	5	12H7	153
110	174,25	175,07	6,5	5	12H7	154
111	175,85	176,66	6,5	5	12H7	156
112	177,45	178,25	6,5	5	12H7	157
113	179,05	179,85	6,5	5	12H7	159
114	180,65	181,44	6,5	5	12H7	161

# Timing pulleys self-tracking Profiles

## Self-tracking pulleys TK 10 K13

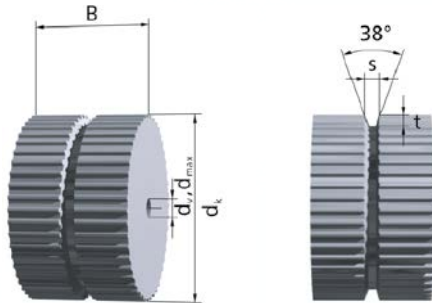

**Order example:**

Self-tracking pulley **Al 55 TK 10 K13 / 32 d = 15H7**

Material \_\_\_\_\_

Width B \_\_\_\_\_

Type / pitch \_\_\_\_\_

Number of teeth \_\_\_\_\_

Bore \_\_\_\_\_

Refer to page 14 for further ordering information.

Belt width	b [mm]	32	50	75	100	150
Pulley width	B [mm]	37	55	80	105	155

**Material:**

AlCu4MgSi, RoHS-conformant

Intermediate and larger widths possible.

- z = Number of teeth
- d<sub>k</sub> = Outside diameter
- d<sub>0</sub> = Pitch circle diameter
- s = Groove width
- t = Groove depth
- d<sub>v</sub> = Pre-bore diameter
- d<sub>max</sub> = max. bore diameter without keyway for flanged timing pulleys

z	d <sub>k</sub> [mm]	d <sub>0</sub> [mm]	s [mm]	t [mm]	Bore	
					d <sub>v</sub> [mm]	d <sub>max</sub> [mm]
20	61,80	63,66	13,5	7,5	12H7	37
21	65,00	66,85	13,5	7,5	12H7	40
22	68,20	70,03	13,5	7,5	12H7	43
23	71,35	73,21	13,5	7,5	12H7	46
24	74,55	76,39	13,5	7,5	12H7	50
25	77,75	79,58	13,5	7,5	12H7	53
26	80,90	82,76	13,5	7,5	12H7	56
27	84,10	85,94	13,5	7,5	12H7	59
28	87,25	89,13	13,5	7,5	12H7	62
29	90,45	92,31	13,5	7,5	12H7	65

z	d <sub>k</sub> [mm]	d <sub>0</sub> [mm]	s [mm]	t [mm]	Bore	
					d <sub>v</sub> [mm]	d <sub>max</sub> [mm]
30	93,65	95,49	13,5	7,5	12H7	69
31	96,80	98,68	13,5	7,5	12H7	72
32	100,00	101,86	13,5	7,5	12H7	75
33	103,20	105,04	13,5	7,5	12H7	78
34	106,35	108,23	13,5	7,5	12H7	81
35	109,55	111,41	13,5	7,5	12H7	85
36	112,75	114,59	13,5	7,5	16H7	88
37	115,90	117,77	13,5	7,5	16H7	91
38	119,10	120,96	13,5	7,5	16H7	94
39	122,30	124,14	13,5	7,5	16H7	97
40	125,45	127,32	13,5	7,5	16H7	100
41	128,65	130,51	13,5	7,5	16H7	104
42	131,85	133,69	13,5	7,5	16H7	107
43	135,00	136,87	13,5	7,5	16H7	110
44	138,20	140,06	13,5	7,5	16H7	113



## Self-tracking pulleys TK 10 K13

z	d <sub>k</sub> [mm]	d <sub>0</sub> [mm]	s [mm]	t [mm]	Bore	
					d <sub>v</sub> [mm]	d <sub>max</sub> [mm]
45	141,40	143,24	13,5	7,5	16H7	116
46	144,50	146,42	13,5	7,5	16H7	120
47	147,75	149,61	13,5	7,5	16H7	123
48	150,95	152,79	13,5	7,5	16H7	126
49	154,10	155,97	13,5	7,5	16H7	129
50	157,30	159,15	13,5	7,5	16H7	132
51	160,50	162,34	13,5	7,5	16H7	136
52	163,65	165,52	13,5	7,5	16H7	139
53	166,85	168,70	13,5	7,5	16H7	142
54	170,05	171,89	13,5	7,5	16H7	145
55	173,20	175,07	13,5	7,5	16H7	148
56	176,40	178,25	13,5	7,5	16H7	151
57	179,60	181,44	13,5	7,5	16H7	155
58	182,75	184,62	13,5	7,5	16H7	158
59	185,95	187,80	13,5	7,5	16H7	161
60	189,15	190,99	13,5	7,5	16H7	164
61	192,30	194,17	13,5	7,5	16H7	167
62	195,50	197,35	13,5	7,5	16H7	171
63	198,70	200,54	13,5	7,5	16H7	174
64	201,85	203,72	13,5	7,5	16H7	177
65	205,05	206,90	13,5	7,5	16H7	180
66	208,25	210,08	13,5	7,5	16H7	183
67	211,40	213,27	13,5	7,5	16H7	186
68	214,60	216,45	13,5	7,5	16H7	190
69	217,80	219,63	13,5	7,5	16H7	193
70	220,95	222,82	13,5	7,5	16H7	196
71	224,15	226,00	13,5	7,5	16H7	199
72	227,35	229,18	13,5	7,5	16H7	202
73	230,50	232,37	13,5	7,5	20H7	206
74	233,70	235,55	13,5	7,5	20H7	209
75	236,90	238,73	13,5	7,5	20H7	212
76	240,05	241,92	13,5	7,5	20H7	215
77	243,25	245,10	13,5	7,5	20H7	218
78	246,40	248,28	13,5	7,5	20H7	221
79	249,60	251,46	13,5	7,5	20H7	225

z	d <sub>k</sub> [mm]	d <sub>0</sub> [mm]	s [mm]	t [mm]	Bore	
					d <sub>v</sub> [mm]	d <sub>max</sub> [mm]
80	252,80	254,65	13,5	7,5	20H7	228
81	255,95	257,83	13,5	7,5	20H7	231
82	259,15	261,01	13,5	7,5	20H7	234
83	262,35	264,20	13,5	7,5	20H7	237
84	265,50	267,38	13,5	7,5	20H7	241
85	268,70	270,56	13,5	7,5	20H7	244
86	271,90	273,75	13,5	7,5	20H7	247
87	275,05	276,93	13,5	7,5	20H7	250
88	278,25	280,11	13,5	7,5	20H7	253
89	281,45	283,30	13,5	7,5	20H7	256
90	284,60	286,48	13,5	7,5	20H7	260
91	287,80	289,66	13,5	7,5	20H7	263
92	291,00	292,85	13,5	7,5	20H7	266
93	294,15	296,03	13,5	7,5	20H7	269
94	297,35	299,21	13,5	7,5	20H7	272
95	300,55	302,39	13,5	7,5	24H7	276
96	303,70	305,58	13,5	7,5	24H7	279
97	306,90	308,76	13,5	7,5	24H7	282
98	310,10	311,94	13,5	7,5	24H7	285
99	313,25	315,13	13,5	7,5	24H7	288
100	316,45	318,31	13,5	7,5	24H7	291
101	319,65	321,49	13,5	7,5	24H7	295
102	322,80	324,68	13,5	7,5	24H7	298
103	326,00	327,86	13,5	7,5	24H7	301
104	329,20	331,04	13,5	7,5	24H7	304
105	332,35	334,23	13,5	7,5	24H7	307
106	335,55	337,41	13,5	7,5	24H7	311
107	338,75	340,59	13,5	7,5	24H7	314
108	341,90	343,77	13,5	7,5	24H7	317
109	345,10	346,96	13,5	7,5	24H7	320
110	348,30	350,14	13,5	7,5	24H7	323
111	351,45	353,32	13,5	7,5	24H7	326
112	354,65	356,51	13,5	7,5	24H7	330
113	357,85	359,69	13,5	7,5	24H7	333
114	361,00	362,87	13,5	7,5	24H7	336

# Timing pulleys self-tracking Profiles

## Self-tracking pulleys TK 10 K6

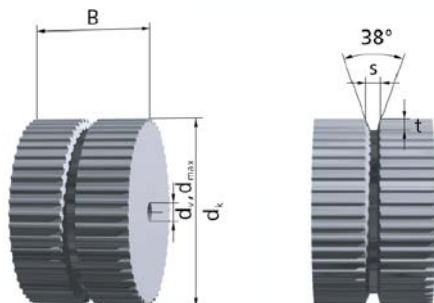

**Order example:**

Self-tracking pulley **Al 55 TK 10 K6 / 32 d = 15H7**

Material \_\_\_\_\_

Width B \_\_\_\_\_

Type / pitch \_\_\_\_\_

Number of teeth \_\_\_\_\_

Bore \_\_\_\_\_

Refer to page 14 for further ordering information.

Belt width	b [mm]	25	50
Pulley width	B [mm]	30	55

**Material:**

AlCu4MgSi, RoHS-conformant

Intermediate and larger widths possible.

- z = Number of teeth
- d<sub>k</sub> = Outside diameter
- d<sub>0</sub> = Pitch circle diameter
- s = Groove width
- t = Groove depth
- d<sub>v</sub> = Pre-bore diameter
- d<sub>max</sub> = max. bore diameter without keyway for flanged timing pulleys

z	d <sub>k</sub> [mm]	d <sub>0</sub> [mm]	s [mm]	t [mm]	Bore	
					d <sub>v</sub> [mm]	d <sub>max</sub> [mm]
20	61,80	63,66	6,5	5	12H7	42
21	65,00	66,85	6,5	5	12H7	45
22	68,20	70,03	6,5	5	12H7	48
23	71,35	73,21	6,5	5	12H7	51
24	74,55	76,39	6,5	5	12H7	55
25	77,75	79,58	6,5	5	12H7	58
26	80,90	82,76	6,5	5	12H7	61
27	84,10	85,94	6,5	5	12H7	64
28	87,25	89,13	6,5	5	12H7	67
29	90,45	92,31	6,5	5	12H7	70

z	d <sub>k</sub> [mm]	d <sub>0</sub> [mm]	s [mm]	t [mm]	Bore	
					d <sub>v</sub> [mm]	d <sub>max</sub> [mm]
30	93,65	95,49	6,5	5	12H7	74
31	96,80	98,68	6,5	5	12H7	77
32	100,00	101,86	6,5	5	12H7	80
33	103,20	105,04	6,5	5	12H7	83
34	106,35	108,23	6,5	5	12H7	86
35	109,55	111,41	6,5	5	12H7	90
36	112,75	114,59	6,5	5	16H7	93
37	115,90	117,77	6,5	5	16H7	96
38	119,10	120,96	6,5	5	16H7	99
39	122,30	124,14	6,5	5	16H7	102
40	125,45	127,32	6,5	5	16H7	105
41	128,65	130,51	6,5	5	16H7	109
42	131,85	133,69	6,5	5	16H7	112
43	135,00	136,87	6,5	5	16H7	115
44	138,20	140,06	6,5	5	16H7	118

## Self-tracking pulleys TK 10 K6

z	d <sub>k</sub> [mm]	d <sub>0</sub> [mm]	s [mm]	t [mm]	Bore	
					d <sub>v</sub> [mm]	d <sub>max</sub> [mm]
45	141,40	143,24	6,5	5	16H7	121
46	144,50	146,42	6,5	5	16H7	125
47	147,75	149,61	6,5	5	16H7	128
48	150,95	152,79	6,5	5	16H7	131
49	154,10	155,97	6,5	5	16H7	134
50	157,30	159,15	6,5	5	16H7	137
51	160,50	162,34	6,5	5	16H7	141
52	163,65	165,52	6,5	5	16H7	144
53	166,85	168,70	6,5	5	16H7	147
54	170,05	171,89	6,5	5	16H7	150
55	173,20	175,07	6,5	5	16H7	153
56	176,40	178,25	6,5	5	16H7	156
57	179,60	181,44	6,5	5	16H7	160
58	182,75	184,62	6,5	5	16H7	163
59	185,95	187,80	6,5	5	16H7	166
60	189,15	190,99	6,5	5	16H7	169
61	192,30	194,17	6,5	5	16H7	172
62	195,50	197,35	6,5	5	16H7	176
63	198,70	200,54	6,5	5	16H7	179
64	201,85	203,72	6,5	5	16H7	182
65	205,05	206,90	6,5	5	16H7	185
66	208,25	210,08	6,5	5	16H7	188
67	211,40	213,27	6,5	5	16H7	191
68	214,60	216,45	6,5	5	16H7	195
69	217,80	219,63	6,5	5	16H7	198
70	220,95	222,82	6,5	5	16H7	201
71	224,15	226,00	6,5	5	16H7	204
72	227,35	229,18	6,5	5	20H7	207
73	230,50	232,37	6,5	5	20H7	211
74	233,70	235,55	6,5	5	20H7	214
75	236,90	238,73	6,5	5	20H7	217
76	240,05	241,92	6,5	5	20H7	220
77	243,25	245,10	6,5	5	20H7	223
78	246,40	248,28	6,5	5	20H7	226
79	249,60	251,46	6,5	5	20H7	230

z	d <sub>k</sub> [mm]	d <sub>0</sub> [mm]	s [mm]	t [mm]	Bore	
					d <sub>v</sub> [mm]	d <sub>max</sub> [mm]
80	252,80	254,65	6,5	5	20H7	233
81	255,95	257,83	6,5	5	20H7	236
82	259,15	261,01	6,5	5	20H7	239
83	262,35	264,20	6,5	5	20H7	242
84	265,50	267,38	6,5	5	20H7	246
85	268,70	270,56	6,5	5	20H7	249
86	271,90	273,75	6,5	5	20H7	252
87	275,05	276,93	6,5	5	20H7	255
88	278,25	280,11	6,5	5	20H7	258
89	281,45	283,30	6,5	5	20H7	261
90	284,60	286,48	6,5	5	20H7	265
91	287,80	289,66	6,5	5	20H7	268
92	291,00	292,85	6,5	5	20H7	271
93	294,15	296,03	6,5	5	20H7	274
94	297,35	299,21	6,5	5	20H7	277
95	300,55	302,39	6,5	5	24H7	281
96	303,70	305,58	6,5	5	24H7	284
97	306,90	308,76	6,5	5	24H7	287
98	310,10	311,94	6,5	5	24H7	290
99	313,25	315,13	6,5	5	24H7	293
100	316,45	318,31	6,5	5	24H7	296
101	319,65	321,49	6,5	5	24H7	300
102	322,80	324,68	6,5	5	24H7	303
103	326,00	327,86	6,5	5	24H7	306
104	329,20	331,04	6,5	5	24H7	309
105	332,35	334,23	6,5	5	24H7	312
106	335,55	337,41	6,5	5	24H7	316
107	338,75	340,59	6,5	5	24H7	319
108	341,90	343,77	6,5	5	24H7	322
109	345,10	346,96	6,5	5	24H7	325
110	348,30	350,14	6,5	5	24H7	328
111	351,45	353,32	6,5	5	24H7	331
112	354,65	356,51	6,5	5	24H7	335
113	357,85	359,69	6,5	5	24H7	338
114	361,00	362,87	6,5	5	24H7	341

# Timing pulleys self-tracking Profiles

## Self-tracking pulleys TK 20 K13

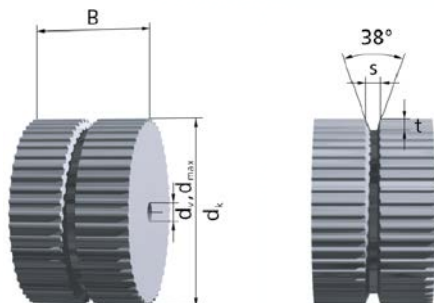

**Order example:**

Self-tracking pulley Al 55 TK 20 K13 / 32 d =15H7  
 Material \_\_\_\_\_  
 Width B \_\_\_\_\_  
 Type / pitch \_\_\_\_\_  
 Number of teeth \_\_\_\_\_  
 Bore \_\_\_\_\_

Refer to page 14 for further ordering information.

Belt width	b [mm]	50	75	100	150
Pulley width	B [mm]	55	80	105	155

**Material:**  
 AlCu4MgSi, RoHS-conformant

Intermediate and larger widths possible.

- z = Number of teeth
- d<sub>k</sub> = Outside diameter
- d<sub>0</sub> = Pitch circle diameter
- s = Groove width
- t = Groove depth
- d<sub>v</sub> = Pre-bore diameter
- d<sub>max</sub> = max. bore diameter without keyway for flanged timing pulleys

z	d <sub>k</sub> [mm]	d <sub>0</sub> [mm]	s [mm]	t [mm]	Bore	
					d <sub>v</sub> [mm]	d <sub>max</sub> [mm]
15	92,65	95,49	13,5	7,5	12H7	62
16	99,00	101,86	13,5	7,5	12H7	69
17	105,35	108,23	13,5	7,5	12H7	75
18	111,75	114,59	13,5	7,5	12H7	91
19	118,10	120,96	13,5	7,5	12H7	98
<hr/>						
20	124,45	127,32	13,5	7,5	16H7	94
21	130,85	133,69	13,5	7,5	16H7	100
22	137,20	140,06	13,5	7,5	16H7	107
23	143,55	146,42	13,5	7,5	16H7	113
24	149,95	152,79	13,5	7,5	16H7	119
<hr/>						
25	156,30	159,15	13,5	7,5	16H7	126
26	162,65	165,52	13,5	7,5	16H7	132
27	169,05	171,89	13,5	7,5	16H7	139
28	175,40	178,25	13,5	7,5	16H7	145
29	181,75	184,62	13,5	7,5	16H7	151

z	d <sub>k</sub> [mm]	d <sub>0</sub> [mm]	s [mm]	t [mm]	Bore	
					d <sub>v</sub> [mm]	d <sub>max</sub> [mm]
30	188,15	190,99	13,5	7,5	16H7	158
31	194,50	197,35	13,5	7,5	16H7	164
32	200,85	203,72	13,5	7,5	16H7	170
33	207,25	210,08	13,5	7,5	16H7	177
34	213,60	216,45	13,5	7,5	16H7	183
<hr/>						
35	219,95	222,82	13,5	7,5	16H7	190
36	226,35	229,18	13,5	7,5	18H7	196
37	232,70	235,55	13,5	7,5	18H7	202
38	239,05	241,92	13,5	7,5	18H7	209
39	245,40	248,28	13,5	7,5	18H7	215
<hr/>						
40	251,80	254,65	13,5	7,5	18H7	221
41	258,15	261,01	13,5	7,5	18H7	228
42	264,50	267,38	13,5	7,5	18H7	234
43	270,90	273,75	13,5	7,5	18H7	240
44	277,25	280,11	13,5	7,5	18H7	247



## Self-tracking pulleys TK 20 K13

z	d <sub>k</sub> [mm]	d <sub>0</sub> [mm]	s [mm]	t [mm]	Bore	
					d <sub>v</sub> [mm]	d <sub>max</sub> [mm]
45	283,60	286,48	13,5	7,5	18H7	253
46	290,00	292,85	13,5	7,5	18H7	260
47	296,35	299,21	13,5	7,5	18H7	266
48	302,70	305,58	13,5	7,5	18H7	272
49	309,10	311,94	13,5	7,5	20H7	279
50	315,45	318,31	13,5	7,5	20H7	285
51	321,80	324,68	13,5	7,5	20H7	292
52	328,20	331,04	13,5	7,5	20H7	298
53	334,55	337,41	13,5	7,5	20H7	304
54	340,90	343,77	13,5	7,5	20H7	310
55	347,30	350,14	13,5	7,5	20H7	317
56	353,65	356,51	13,5	7,5	20H7	323
57	360,00	362,87	13,5	7,5	20H7	330
58	366,40	369,24	13,5	7,5	20H7	336
59	372,75	375,61	13,5	7,5	20H7	342
60	379,10	381,97	13,5	7,5	20H7	349
61	385,50	388,34	13,5	7,5	20H7	355
62	391,85	394,70	13,5	7,5	20H7	362
63	398,20	401,07	13,5	7,5	20H7	368
64	404,55	407,44	13,5	7,5	20H7	374
65	410,95	413,80	13,5	7,5	20H7	380
66	417,30	420,17	13,5	7,5	20H7	387
67	423,65	426,54	13,5	7,5	20H7	393
68	430,05	432,90	13,5	7,5	20H7	400
69	436,40	439,27	13,5	7,5	20H7	406
70	442,75	445,63	13,5	7,5	20H7	412
71	449,15	452,00	13,5	7,5	20H7	419
72	455,50	458,37	13,5	7,5	20H7	425
73	461,85	464,73	13,5	7,5	30H7	431
74	468,25	471,10	13,5	7,5	30H7	438
75	474,60	477,46	13,5	7,5	30H7	444
76	480,95	483,83	13,5	7,5	30H7	451
77	487,35	490,20	13,5	7,5	30H7	457
78	493,70	496,56	13,5	7,5	30H7	463
79	500,05	502,93	13,5	7,5	30H7	470

z	d <sub>k</sub> [mm]	d <sub>0</sub> [mm]	s [mm]	t [mm]	Bore	
					d <sub>v</sub> [mm]	d <sub>max</sub> [mm]
80	506,45	509,30	13,5	7,5	30H7	476
81	512,80	515,66	13,5	7,5	30H7	482
82	519,15	522,03	13,5	7,5	30H7	489
83	525,55	528,39	13,5	7,5	30H7	495
84	531,90	534,76	13,5	7,5	30H7	500
85	538,25	541,13	13,5	7,5	30H7	500
86	544,65	547,49	13,5	7,5	30H7	504
87	551,00	553,86	13,5	7,5	30H7	511
88	557,35	560,23	13,5	7,5	30H7	517
89	563,70	566,59	13,5	7,5	30H7	523
90	570,10	572,96	13,5	7,5	30H7	530
91	576,45	579,32	13,5	7,5	30H7	536
92	582,80	585,69	13,5	7,5	30H7	542
93	589,20	592,06	13,5	7,5	30H7	549
94	595,55	598,42	13,5	7,5	30H7	555
95	601,90	604,79	13,5	7,5	40H7	562
96	608,30	611,15	13,5	7,5	40H7	568
97	614,65	617,52	13,5	7,5	40H7	574
98	621,00	623,89	13,5	7,5	40H7	581
99	627,40	630,25	13,5	7,5	40H7	587
100	633,75	636,62	13,5	7,5	40H7	593
101	640,10	642,99	13,5	7,5	40H7	600
102	646,50	649,35	13,5	7,5	40H7	606
103	652,85	655,72	13,5	7,5	40H7	612
104	659,20	662,08	13,5	7,5	40H7	619
105	665,60	668,45	13,5	7,5	40H7	625
106	671,95	674,82	13,5	7,5	40H7	632
107	678,30	681,18	13,5	7,5	40H7	638
108	684,70	687,55	13,5	7,5	40H7	644
109	691,05	693,92	13,5	7,5	40H7	651
110	697,40	700,28	13,5	7,5	40H7	659
111	703,80	706,65	13,5	7,5	40H7	663
112	710,15	713,01	13,5	7,50	40H7	670
113	716,50	719,38	13,5	7,5	40H7	676
114	722,85	725,75	13,5	7,5	40H7	682

# Timing pulleys self-tracking Profiles

## Self-tracking pulleys TK H K13 (Profile TK 1/2" K13)

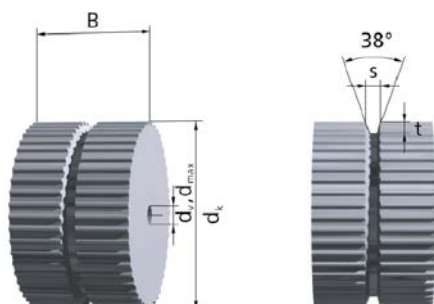

### Order example:

Self-tracking pulley Al 55 TK H K13 / 32 d = 15H7  
 Material \_\_\_\_\_  
 Width B \_\_\_\_\_  
 Type / pitch \_\_\_\_\_  
 Number of teeth \_\_\_\_\_  
 Bore \_\_\_\_\_

Refer to page 14 for further ordering information.

Belt width	b [mm]	38,1	50,8	76,2	101,6
Pulley width	B [mm]	42	55	80	105

**Material:**  
 AlCu4MgSi, RoHS-conformant

Intermediate and larger widths possible.

- z = Number of teeth
- d<sub>k</sub> = Outside diameter
- d<sub>0</sub> = Pitch circle diameter
- s = Groove width
- t = Groove depth
- d<sub>v</sub> = Pre-bore diameter
- d<sub>max</sub> = max. bore diameter without keyway for flanged timing pulleys

z	d <sub>k</sub> [mm]	d <sub>0</sub> [mm]	s [mm]	t [mm]	Bore	
					d <sub>v</sub> [mm]	d <sub>max</sub> [mm]
18	71,40	72,77	13,5	7,5	12H7	47
19	75,44	76,81	13,5	7,5	12H7	51
20	79,48	80,85	13,5	7,5	12H7	55
21	83,52	84,89	13,5	7,5	12H7	60
22	87,57	88,94	13,5	7,5	12H7	64
23	91,61	92,98	13,5	7,5	12H7	68
24	95,65	97,02	13,5	7,5	12H7	72
25	99,69	101,06	13,5	7,5	15H7	76
26	103,74	105,11	13,5	7,5	15H7	80
27	107,78	109,15	13,5	7,5	15H7	84
28	111,82	113,19	13,5	7,5	15H7	88
29	115,86	117,23	13,5	7,5	15H7	92

z	d <sub>k</sub> [mm]	d <sub>0</sub> [mm]	s [mm]	t [mm]	Bore	
					d <sub>v</sub> [mm]	d <sub>max</sub> [mm]
30	119,91	121,28	13,5	7,5	15H7	96
31	123,95	125,32	13,5	7,5	20H7	100
32	127,99	129,36	13,5	7,5	20H7	104
33	132,03	133,40	13,5	7,5	20H7	108
34	136,08	137,45	13,5	7,5	20H7	112
35	140,12	141,49	13,5	7,5	20H7	116
36	144,16	145,53	13,5	7,5	20H7	120
37	148,20	149,57	13,5	7,5	20H7	124
38	152,25	153,62	13,5	7,5	20H7	128
39	156,29	157,66	13,5	7,5	20H7	132
40	160,33	161,70	13,5	7,5	20H7	136
41	164,37	165,74	13,5	7,5	20H7	140
42	168,42	169,79	13,5	7,5	20H7	144
43	172,46	173,83	13,5	7,5	20H7	148
44	176,50	177,87	13,5	7,5	20H7	153

## Self-tracking pulleys TK H K13 (Profile TK 1/2" K13)

z	d <sub>k</sub> [mm]	d <sub>0</sub> [mm]	s [mm]	t [mm]	Bore	
					d <sub>v</sub> [mm]	d <sub>max</sub> [mm]
45	180,54	181,91	13,5	7,5	20H7	157
46	184,59	185,96	13,5	7,5	20H7	161
47	188,63	190,00	13,5	7,5	20H7	165
48	192,67	194,04	13,5	7,5	20H7	169
49	196,71	198,08	13,5	7,5	20H7	173
50	200,76	202,13	13,5	7,5	20H7	177
51	204,80	206,17	13,5	7,5	20H7	181
52	208,84	210,21	13,5	7,5	20H7	185
53	212,88	214,25	13,5	7,5	20H7	189
54	216,93	218,30	13,5	7,5	20H7	193
55	220,97	222,34	13,5	7,5	20H7	197
56	225,01	226,38	13,5	7,5	20H7	201
57	229,05	230,42	13,5	7,5	20H7	205
58	233,10	234,47	13,5	7,5	20H7	209
59	237,14	238,51	13,5	7,5	20H7	213
60	241,18	242,55	13,5	7,5	20H7	217
61	245,22	246,59	13,5	7,5	20H7	221
62	249,27	250,64	13,5	7,5	20H7	225
63	253,31	254,68	13,5	7,5	20H7	229
64	257,35	258,72	13,5	7,5	20H7	233
65	261,39	262,76	13,5	7,5	20H7	237
66	265,44	266,81	13,5	7,5	20H7	241
67	269,48	270,85	13,5	7,5	20H7	245
68	273,52	274,89	13,5	7,5	20H7	250
69	277,56	278,93	13,5	7,5	20H7	254
70	281,61	282,98	13,5	7,5	20H7	258
71	285,65	287,02	13,5	7,5	20H7	262
72	289,69	291,06	13,5	7,5	20H7	266
73	293,73	295,11	13,5	7,5	20H7	270
74	297,78	299,15	13,5	7,5	20H7	274
75	301,82	303,19	13,5	7,5	20H7	278
76	305,86	307,23	13,5	7,5	20H7	282
77	309,90	311,28	13,5	7,5	20H7	286
78	313,95	315,32	13,5	7,5	20H7	290
79	317,99	319,36	13,5	7,5	20H7	294

z	d <sub>k</sub> [mm]	d <sub>0</sub> [mm]	s [mm]	t [mm]	Bore	
					d <sub>v</sub> [mm]	d <sub>max</sub> [mm]
80	322,03	323,40	13,5	7,5	20H7	298
81	326,07	327,45	13,5	7,5	20H7	302
82	330,12	331,49	13,5	7,5	20H7	306
83	334,16	335,53	13,5	7,5	20H7	310
84	338,20	339,57	13,5	7,5	20H7	314
85	342,24	343,62	13,5	7,5	20H7	318
86	346,29	347,66	13,5	7,5	20H7	322
87	350,33	351,70	13,5	7,5	20H7	326
88	354,37	355,74	13,5	7,5	20H7	330
89	358,41	359,79	13,5	7,5	20H7	334
90	362,46	363,83	13,5	7,5	20H7	338
91	366,50	367,87	13,5	7,5	20H7	342
92	370,54	371,91	13,5	7,5	20H7	347
93	374,58	375,96	13,5	7,5	20H7	351
94	378,63	380,00	13,5	7,5	20H7	355
95	382,67	384,04	13,5	7,5	20H7	359
96	386,71	388,08	13,5	7,5	20H7	363
97	390,76	392,13	13,5	7,5	24H7	367
98	394,80	396,17	13,5	7,5	24H7	371
99	398,84	400,21	13,5	7,5	24H7	375
100	402,88	404,25	13,5	7,5	24H7	379
101	406,93	408,30	13,5	7,5	24H7	383
102	410,97	412,34	13,5	7,5	24H7	387
103	415,01	416,38	13,5	7,5	24H7	391
104	419,05	420,42	13,5	7,5	24H7	395
105	423,10	424,47	13,5	7,5	24H7	399
106	427,14	428,51	13,5	7,5	24H7	403
107	431,18	432,55	13,5	7,5	24H7	407
108	435,22	436,59	13,5	7,5	24H7	411
109	439,27	440,64	13,5	7,5	24H7	415
110	443,31	444,68	13,5	7,5	24H7	419
111	447,35	448,72	13,5	7,5	24H7	423
112	451,39	452,76	13,5	7,50	24H7	427
113	455,44	456,81	13,5	7,5	24H7	431
114	459,48	460,85	13,5	7,5	24H7	435

# Timing pulleys T-Profile

## T 2

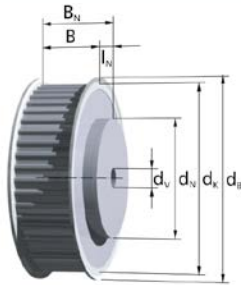

Stock pulleys over  $z = 24$  with flanges

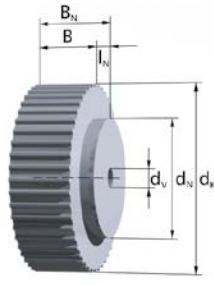

Stock pulleys up to  $z = 20$  without flanges

**Order example:**

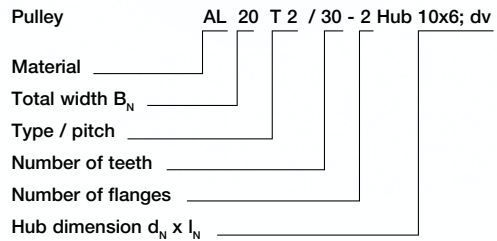

Note for part code:

$d_v$  = Diameter pre-drilled.

Refer to page 14 for further ordering information.

Belt width	b [mm]	4	6	10
Pulley width	B [mm]	8	10	14
Total width	$B_N$ [mm]	14	16	20

**Materials:**

Pulley: AlCu4MgSi, RoHS-conformant

Flange: Galvanized steel

The stock pulleys with standard dimensioning are marked in blue.

In-between widths and larger widths as well as other hub dimensions are available.

- $z$  = Number of teeth
- $d_k$  = Outside diameter
- $d_0$  = Pitch circle diameter
- $d_B$  = Flange diameter
- $d_N$  = Hub diameter

- $l_N$  = Hub length
- $d_v$  = Pre-bore diameter
- $d_{max}$  = max. bore diameter without keyway for flanged timing pulleys; no hub at maximum pre-bore

z	Hub			Bore		
	$d_k$ [mm]	$d_0$ [mm]	$d_B$ [mm]	$d_N \times l_N$ [mm]	$d_v$ [mm]	$d_{max}$ [mm]
15	9,00	9,55	13	-	3H7	3,5
16	9,64	10,19	13	-	3H7	3,5
17	10,27	10,82	14	-	3H7	4
18	10,91	11,46	14	-	3H7	4
19	11,55	12,10	15	-	3H7	5
20	12,18	12,73	15	-	3H7	5
21	12,82	13,37	16	-	3H7	6
22	13,46	14,01	16	-	3H7	6
23	14,09	14,64	18	-	3H7	8
24	14,73	15,28	18	10x6	3H7	8
25	15,37	15,92	19	10x6	3H7	9
26	16,00	16,55	19	10x6	3H7	9
27	16,64	17,19	20	10x6	3H7	10
28	17,28	17,83	20	10x6	3H7	10
29	17,91	18,46	22	10x6	3H7	11

z	Hub			Bore		
	$d_k$ [mm]	$d_0$ [mm]	$d_B$ [mm]	$d_N \times l_N$ [mm]	$d_v$ [mm]	$d_{max}$ [mm]
30	18,55	19,10	22	10x6	3H7	12
31	19,19	19,74	22	10x6	3H7	12
32	19,82	20,37	24	14x6	3H7	13
33	20,46	21,01	24	14x6	3H7	13
34	21,10	21,65	24	14x6	3H7	13
35	21,73	22,28	25	14x6	3H7	14
36	22,37	22,92	26	14x6	3H7	14
37	23,00	23,55	26	14x6	3H7	14
38	23,64	24,19	28	14x6	3H7	16
39	24,28	24,83	28	14x6	3H7	16
40	24,91	25,46	28	14x6	3H7	16
41	25,55	26,10	30	14x6	3H7	18
42	26,19	26,74	30	14x6	3H7	18
43	26,82	27,37	30	14x6	3H7	18
44	27,46	28,01	32	14x6	3H7	18



## T 2

z	Hub			Bore		
	d <sub>K</sub> [mm]	d <sub>0</sub> [mm]	d <sub>B</sub> [mm]	d <sub>N</sub> x l <sub>N</sub> [mm]	d <sub>V</sub> [mm]	d <sub>max</sub> [mm]
45	28,10	28,65	32	14x6	3H7	18
46	28,73	29,28	32	14x6	3H7	18
47	29,37	29,92	35	14x6	4H7	21
48	30,01	30,56	35	20x6	4H7	21
49	30,64	31,19	35	20x6	4H7	21
50	31,28	31,83	35	20x6	4H7	21
51	31,92	32,47	36	20x6	4H7	21
52	32,55	33,10	36	20x6	4H7	21
53	33,19	33,74	36	20x6	4H7	21
54	33,83	34,38	40	20x6	4H7	24
55	34,46	35,01	40	20x6	4H7	24
56	35,10	35,65	40	20x6	4H7	24
57	35,74	36,29	42	20x6	4H7	26
58	36,37	36,92	42	20x6	4H7	26
59	37,01	37,65	42	20x6	4H7	26
60	37,65	38,20	42	20x6	4H7	26
61	38,28	38,83	42	26x6	4H7	26
62	38,92	39,47	45	26x6	4H7	28
63	39,56	40,11	45	26x6	6H7	28
64	40,19	40,74	45	26x6	6H7	28
65	40,83	41,38	45	26x6	6H7	28
66	41,47	42,08	47	26x6	6H7	33
67	42,10	42,65	47	26x6	6H7	33
68	42,74	43,29	47	26x6	6H7	33
69	43,38	43,93	47	26x6	6H7	33
70	44,01	44,56	50	26x6	6H7	36
71	44,65	45,20	50	26x6	6H7	36
72	45,29	45,84	50	26x6	6H7	36
73	45,92	46,47	50	34x6	6H7	36
74	46,56	47,11	50	34x6	6H7	36
75	47,20	47,75	53	34x6	6H7	36
76	47,83	48,38	53	34x6	6H7	36
77	48,47	49,02	53	34x6	6H7	36
78	49,11	49,66	55	34x6	6H7	41
79	49,74	50,29	55	34x6	6H7	41

z	Hub			Bore		
	d <sub>K</sub> [mm]	d <sub>0</sub> [mm]	d <sub>B</sub> [mm]	d <sub>N</sub> x l <sub>N</sub> [mm]	d <sub>V</sub> [mm]	d <sub>max</sub> [mm]
80	50,38	50,93	55	34x6	6H7	41
81	51,02	51,57	55	34x6	6H7	41
82	51,65	52,20	56	34x6	6H7	42
83	52,29	52,84	56	34x6	6H7	42
84	52,93	53,48	58	34x6	6H7	44
85	53,56	54,11	58	34x6	6H7	44
86	54,20	54,75	58	34x6	6H7	44
87	54,84	55,39	60	34x6	6H7	46
88	55,47	56,02	60	34x6	6H7	46
89	56,11	56,66	61	34x6	8H7	47
90	56,75	57,30	62	34x6	8H7	48
91	57,39	57,93	62	38x6	8H7	48
92	58,02	58,57	62	38x6	8H7	48
93	58,66	59,21	64	38x6	8H7	50
94	59,29	59,84	64	38x6	8H7	50
95	59,93	60,48	64	38x6	8H7	50
96	60,57	61,12	66	38x6	8H7	51
97	61,20	61,75	66	38x6	8H7	51
98	61,84	62,39	66	38x6	8H7	52
99	62,48	63,03	68	38x6	8H7	53
100	63,11	63,66	68	38x6	8H7	54
101	63,75	64,30	70	38x6	8H7	56
102	64,39	64,94	70	38x6	8H7	56
103	65,02	65,57	70	38x6	8H7	56
104	65,66	66,21	72	38x6	8H7	58
105	66,30	66,85	72	38x6	8H7	58
106	66,93	67,48	72	38x6	8H7	58
107	67,57	68,12	72	38x6	8H7	58
108	68,20	68,75	74	38x6	8H7	60
109	68,84	69,39	74	38x6	8H7	60
110	69,48	70,03	75	38x6	8H7	61
111	70,11	70,66	75	38x6	8H7	61
112	70,75	71,30	75	38x6	8H7	61
113	71,39	71,94	76	40x6	10H7	62
114	72,02	72,57	78	40x6	10H7	62

# Timing pulleys T-Profile

## T 2.5

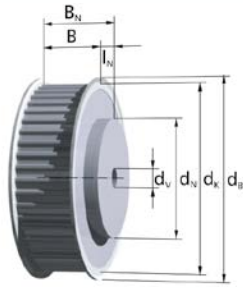

Stock pulleys up to z = 40 with flanges

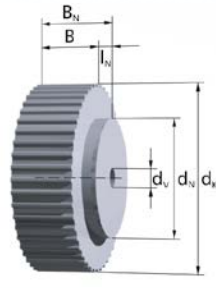

Stock pulleys over z = 48 without flanges

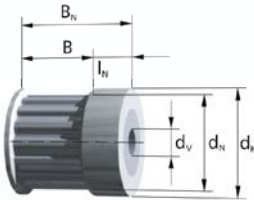

Stock pulleys up to z = 16

The stock pulleys with standard dimensioning are marked in blue.

In-between widths and larger widths as well as other hub dimensions are available.

- z = Number of teeth
- d<sub>k</sub> = Outside diameter
- d<sub>0</sub> = Pitch circle diameter
- d<sub>B</sub> = Flange diameter
- d<sub>N</sub> = Hub diameter

### Order example:

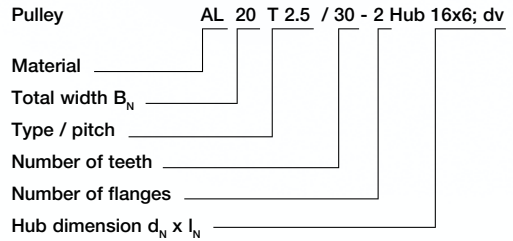

Note for part code:

dv = Diameter pre-drilled.

Refer to page 14 for further ordering information.

### Materials:

- Pulley: AlCu4MgSi, RoHS-conformant
- Flange: Galvanized steel

Belt width	b [mm]	4	6	8	10	20
Pulley width	B [mm]	8	10	12	14	24
Total width	B <sub>N</sub> [mm]	14	16	18	20	30

- l<sub>N</sub> = Hub length
- d<sub>v</sub> = Pre-bore diameter
- d<sub>max</sub> = max. bore diameter without keyway for flanged timing pulleys; no hub at maximum pre-bore

z	Hub			Bore		
	d <sub>k</sub> [mm]	d <sub>0</sub> [mm]	d <sub>B</sub> [mm]	d <sub>N</sub> x l <sub>N</sub> [mm]	d <sub>v</sub> [mm]	d <sub>max</sub> [mm]
10	7,45	7,96	10	10x6	3H7	3
11	8,25	8,75	12	10x6	3H7	3
12	9,00	9,55	12	12x6	3H7	3
13	9,80	10,35	13	12x6	3H7	3,5
14	10,60	11,14	14	14x6	3H7	4
15	11,40	11,94	15	15x6	3H7	5
16	12,20	12,73	16	16x6	4H7	6
17	13,00	13,53	16	10x6	4H7	7
18	13,80	14,32	17	10x6	4H7	7
19	14,60	15,12	18	10x6	4H7	8

z	Hub			Bore		
	d <sub>k</sub> [mm]	d <sub>0</sub> [mm]	d <sub>B</sub> [mm]	d <sub>N</sub> x l <sub>N</sub> [mm]	d <sub>v</sub> [mm]	d <sub>max</sub> [mm]
20	15,40	15,92	19	12x6	4H7	9
21	16,20	16,71	20	12x6	4H7	10
22	17,00	17,51	20	12x6	4H7	10
23	17,80	18,30	21	12x6	4H7	11
24	18,55	19,10	22	14x6	4H7	11
25	19,35	19,89	23	14x6	4H7	12
26	20,15	20,69	23	14x6	4H7	13
27	20,95	21,49	24	14x6	4H7	13
28	21,75	22,28	25	14x6	4H7	13
29	22,55	23,08	26	14x6	4H7	14
30	23,35	23,87	28	16x6	6H7	15
31	24,15	24,67	28	16x6	6H7	16
32	24,95	25,46	28	16x6	6H7	16
33	25,75	26,26	30	16x6	6H7	17
34	26,55	27,06	30	16x6	6H7	17

## T 2.5

z	Hub			Bore		
	d <sub>K</sub> [mm]	d <sub>0</sub> [mm]	d <sub>B</sub> [mm]	d <sub>N</sub> x l <sub>N</sub> [mm]	d <sub>V</sub> [mm]	d <sub>max</sub> [mm]
35	27,35	27,85	32	16x6	6H7	20
36	28,15	28,65	32	20x6	6H7	20
37	28,90	29,44	32	20x6	6H7	21
38	29,70	30,24	34	20x6	6H7	21
39	30,50	31,04	34	20x6	6H7	22
40	31,30	31,83	35	22x6	6H7	23
41	32,10	32,63	36	22x6	6H7	24
42	32,90	33,42	36	22x6	6H7	24
43	33,70	34,22	37	22x6	6H7	24
44	34,50	35,01	39	22x6	6H7	25
45	35,30	35,81	39	22x6	6H7	26
46	36,10	36,61	40	22x6	6H7	27
47	36,90	37,40	40	22x6	6H7	27
48	37,70	38,20	42	26x6	6H7	27
49	38,45	38,99	42	26x6	6H7	28
50	39,25	39,79	43	26x6	6H7	29
51	40,05	40,58	43	26x6	6H7	30
52	40,85	41,38	45	26x6	6H7	30
53	41,65	42,18	45	26x6	6H7	30
54	42,45	42,97	47	26x6	6H7	31
55	43,25	43,77	47	26x6	6H7	32
56	44,05	44,56	47	26x6	6H7	32
57	44,85	45,36	48	26x6	6H7	32
58	45,65	46,15	50	26x6	6H7	33
59	46,45	46,95	50	26x6	6H7	34
60	47,25	47,75	52	34x6	8H7	35
61	48,05	48,54	52	34x6	8H7	36
62	48,80	49,34	53	34x6	8H7	37
63	49,60	50,13	53	34x6	8H7	37
64	50,40	50,93	55	34x6	8H7	37
65	51,20	51,37	55	34x6	8H7	38
66	52,00	52,52	55	34x6	8H7	38
67	52,80	53,32	56	34x6	8H7	39
68	53,60	54,11	58	34x6	8H7	39
69	54,40	54,91	58	34x6	8H7	40
70	55,20	55,70	60	34x6	8H7	41
71	56,00	56,50	60	34x6	8H7	42
72	56,80	57,30	60	34x6	8H7	42
73	57,60	58,09	61	38x6	8H7	43
74	58,35	58,89	62	38x6	8H7	44

z	Hub			Bore		
	d <sub>K</sub> [mm]	d <sub>0</sub> [mm]	d <sub>B</sub> [mm]	d <sub>N</sub> x l <sub>N</sub> [mm]	d <sub>V</sub> [mm]	d <sub>max</sub> [mm]
75	59,15	59,68	62	38x6	8H7	45
76	59,95	60,48	64	38x6	8H7	45
77	60,75	61,27	64	38x6	8H7	46
78	61,55	62,07	66	38x6	8H7	47
79	62,35	62,87	66	38x6	8H7	47
80	63,15	63,66	68	38x6	8H7	47
81	63,95	64,46	68	38x6	8H7	47
82	64,75	65,25	68	38x6	8H7	48
83	65,55	66,05	70	38x6	8H7	49
84	66,35	66,85	70	38x6	8H7	50
85	67,15	67,64	72	38x6	8H7	50
86	67,95	68,44	72	38x6	8H7	51
87	68,70	69,23	72	38x6	8H7	51
88	69,50	70,03	74	38x6	8H7	52
89	70,30	70,82	74	38x6	8H7	52
90	71,10	71,62	75	38x6	8H7	53
91	71,90	72,42	75	40x6	10H7	53
92	72,70	73,21	76	40x6	10H7	54
93	73,50	74,01	78	40x6	10H7	55
94	74,30	74,80	78	40x6	10H7	55
95	75,10	75,60	80	40x6	10H7	56
96	75,90	76,39	80	40x6	10H7	57
97	76,70	77,19	80	40x6	10H7	57
98	77,50	77,99	82	40x6	10H7	58
99	78,25	78,78	82	40x6	10H7	58
100	79,05	79,58	84	40x6	10H7	59
101	79,85	80,37	84	50x6	10H7	59
102	80,65	81,17	84	50x6	10H7	60
103	81,45	81,96	86	50x6	10H7	61
104	82,25	82,76	86	50x6	10H7	62
105	83,05	83,56	88	50x6	10H7	63
106	83,85	84,35	88	50x6	10H7	63
107	84,65	85,15	88	50x6	10H7	64
108	85,45	85,94	90	50x6	10H7	64
109	86,25	86,74	90	50x6	10H7	65
110	87,05	87,54	91	50x6	10H7	65
111	87,85	88,33	91	50x6	10H7	65
112	88,60	89,13	93	50x6	10H7	66
113	89,40	89,92	93	50x6	10H7	67
114	90,20	90,72	94	50x6	10H7	68

# Timing pulleys T-Profile

## T 5

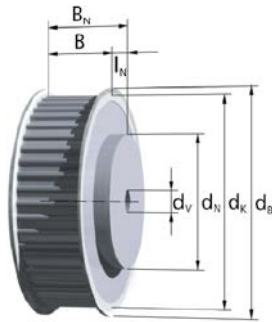

Stock pulleys up to  $z = 40$  with flanges

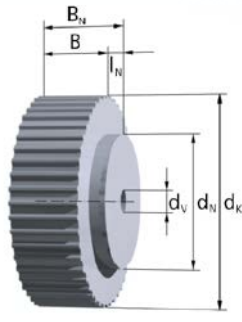

Stock pulleys over  $z = 48$  without flanges

### Order example:

Pulley AL 36 T 5 / 35 - 2 Hub 38x6; dv  
 Material  
 Total width  $B_N$   
 Type / pitch  
 Number of teeth  
 Number of flanges  
 Hub dimension  $d_N \times l_N$

Note for part code:

dv = Diameter pre-drilled.

Refer to page 14 for further ordering information.

Belt width	b [mm]	6	10	16	25
Pulley width	B [mm]	12	15	21	30
Total width	$B_N$ [mm]	18	21	27	36

### Materials:

Pulley: AlCu4MgSi, RoHS-conformant  
 Flange: Galvanized steel

The stock pulleys with standard dimensioning are marked in blue.

In-between widths and larger widths as well as other hub dimensions are available.

- $z$  = Number of teeth
- $d_k$  = Outside diameter
- $d_0$  = Pitch circle diameter
- $d_B$  = Flange diameter
- $d_N$  = Hub diameter

- $l_N$  = Hub length
- $d_v$  = Pre-bore diameter
- $d_{max}$  = max. bore diameter without keyway for flanged timing pulleys; no hub at maximum pre-bore

z	Hub			Bore		
	$d_k$ [mm]	$d_0$ [mm]	$d_B$ [mm]	$d_N \times l_N$ [mm]	$d_v$ [mm]	$d_{max}$ [mm]
10	15,05	15,92	18	8x6	4H7	6
11	16,65	17,50	21	10x6	4H7	6
12	18,25	19,10	23	12x6	4H7	6
13	19,85	20,69	25	12x6	6H7	8
14	21,45	22,28	26	14x6	6H7	8
15	23,05	23,87	28	16x6	6H7	10
16	24,60	25,46	30	18x6	6H7	12
17	26,20	27,06	32	18x6	6H7	14
18	27,80	28,65	34	20x6	6H7	16
19	29,40	30,24	35	22x6	6H7	16

z	Hub			Bore		
	$d_k$ [mm]	$d_0$ [mm]	$d_B$ [mm]	$d_N \times l_N$ [mm]	$d_v$ [mm]	$d_{max}$ [mm]
20	31,00	31,83	36	24x6	6H7	18
21	32,60	33,42	37	24x6	6H7	20
22	34,15	35,01	39	24x6	6H7	22
23	35,75	36,61	40	24x6	6H7	24
24	37,35	38,20	42	26x6	6H7	24
25	38,95	39,79	43	26x6	6H7	25
26	40,55	41,38	45	26x6	8H7	25
27	42,15	42,97	47	30x6	8H7	27
28	43,75	44,56	48	30x6	8H7	29
29	45,30	46,15	50	30x6	8H7	31
30	46,90	47,75	52	34x6	8H7	33
31	48,50	49,34	53	34x6	8H7	35
32	50,10	50,93	55	38x6	8H7	37
33	51,70	52,52	56	38x6	8H7	39
34	53,30	54,11	58	38x6	8H7	39



## T 5

z	Hub			Bore		
	d <sub>K</sub> [mm]	d <sub>0</sub> [mm]	d <sub>B</sub> [mm]	d <sub>N</sub> x l <sub>N</sub> [mm]	d <sub>V</sub> [mm]	d <sub>max</sub> [mm]
35	54,85	55,70	60	38x6	8H7	40
36	56,45	57,30	61	38x6	8H7	42
37	58,05	58,89	62	38x6	8H7	43
38	59,65	60,48	64	38x6	8H7	45
39	61,25	62,07	66	38x6	8H7	45
40	62,85	63,66	68	40x6	8H7	47
41	64,40	65,25	70	40x6	8H7	48
42	66,00	66,85	72	40x6	8H7	50
43	67,60	68,44	72	40x6	8H7	52
44	69,20	70,03	74	40x6	8H7	52
45	70,80	71,62	75	40x6	8H7	54
46	72,40	73,21	76	40x6	8H7	56
47	73,95	74,80	78	40x6	8H7	58
48	75,55	76,39	80	50x6	8H7	60
49	77,15	77,99	82	50x6	8H7	60
50	78,75	79,58	84	50x6	8H7	60
51	80,35	81,17	86	50x6	8H7	62
52	81,95	82,76	86	50x6	8H7	64
53	83,55	84,35	88	50x6	8H7	66
54	85,10	85,94	90	50x6	8H7	66
55	86,70	87,54	91	50x6	8H7	68
56	88,30	89,13	93	50x6	8H7	70
57	89,90	90,72	94	50x6	8H7	72
58	91,50	92,31	96	50x6	8H7	74
59	93,10	93,90	99	50x6	8H7	74
60	94,65	95,49	99	65x6	8H7	76
61	96,25	97,08	100	65x6	8H7	79
62	97,85	98,68	102	65x6	8H7	80
63	99,45	100,27	104	65x6	8H7	82
64	101,05	101,86	105	65x6	8H7	82
65	102,65	103,45	107	65x6	8H7	84
66	104,20	105,04	109	65x6	8H7	86
67	105,80	106,63	112	65x6	8H7	88
68	107,40	108,23	112	65x6	8H7	90
69	109,00	109,82	115	65x6	8H7	90
70	110,60	111,41	115	65x6	8H7	90
71	112,20	113,00	117	65x6	8H7	92
72	113,75	114,59	118	80x6	10H7	94
73	115,35	116,18	121	80x6	10H7	96
74	116,95	117,77	121	80x6	10H7	96

z	Hub			Bore		
	d <sub>K</sub> [mm]	d <sub>0</sub> [mm]	d <sub>B</sub> [mm]	d <sub>N</sub> x l <sub>N</sub> [mm]	d <sub>V</sub> [mm]	d <sub>max</sub> [mm]
75	118,55	119,37	123	80x6	10H7	98
76	120,15	120,96	125	80x6	10H7	100
77	121,75	122,55	128	80x6	10H7	102
78	123,35	124,14	128	80x6	10H7	104
79	124,90	125,73	131	80x6	10H7	104
80	126,50	127,32	131	80x6	10H7	106
81	128,10	128,92	134	80x6	10H7	108
82	129,70	130,51	134	80x6	10H7	110
83	131,30	132,10	137	80x6	10H7	110
84	132,90	133,69	137	80x6	10H7	112
85	134,45	135,28	140	80x6	10H7	114
86	136,05	136,87	142	80x6	10H7	116
87	137,65	138,46	142	80x6	10H7	119
88	139,25	140,06	144	80x6	10H7	119
89	140,85	141,65	147	80x6	10H7	120
90	142,45	143,24	147	80x6	10H7	120
91	144,00	144,83	150	90x6	12H7	122
92	145,60	146,42	150	90x6	12H7	124
93	147,20	148,01	153	90x6	12H7	126
94	148,80	149,61	153	90x6	12H7	126
95	150,40	151,20	156	90x6	12H7	129
96	152,00	152,79	156	90x6	12H7	130
97	153,55	154,38	158	90x6	12H7	130
98	155,15	155,97	160	90x6	12H7	132
99	156,75	157,56	163	90x6	12H7	132
100	158,35	159,15	163	90x6	12H7	134
101	159,95	160,75	166	95x6	12H7	136
102	161,55	162,34	166	95x6	12H7	139
103	163,15	163,93	169	95x6	12H7	140
104	164,70	165,52	169	95x6	12H7	140
105	166,30	167,11	171	95x6	12H7	140
106	167,90	168,70	172	95x6	12H7	142
107	169,50	170,30	174	95x6	12H7	146
108	171,10	171,89	176	95x6	12H7	146
109	172,70	173,48	179	110x6	16H7	148
110	174,25	175,07	179	110x6	16H7	150
111	175,85	176,66	180	110x6	16H7	150
112	177,45	178,25	182	110x6	16H7	152
113	179,05	179,85	185	110x6	16H7	152
114	180,65	181,44	185	110x6	16H7	152

# Timing pulleys T-Profile

## T 10

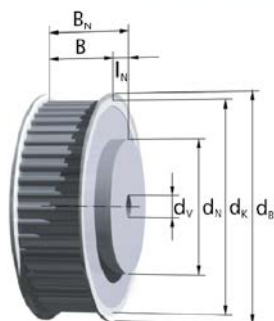

Stock pulleys up to  $z = 40$  with flanges

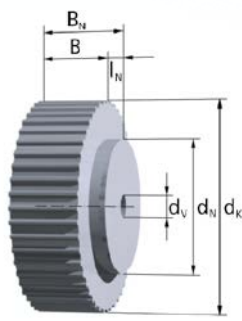

Stock pulleys over  $z = 48$  without flanges

### Order example:

Pulley AL 50 T 10 / 30 - 2 Hub 60x10; dv  
 Material \_\_\_\_\_  
 Total width  $B_N$  \_\_\_\_\_  
 Type / pitch \_\_\_\_\_  
 Number of teeth \_\_\_\_\_  
 Number of flanges \_\_\_\_\_  
 Hub dimension  $d_N \times l_N$  \_\_\_\_\_

Note for part code:

$d_v$  = Diameter pre-drilled.

Refer to page 14 for further ordering information.

Belt width	b [mm]	10	16	25	32*	50*
Pulley width	B [mm]	16	21	30	40	56
Total width	$B_N$ [mm]	26	31	40	50	66

### Materials:

Pulley: AlCu4MgSi, RoHS-conformant  
 Flange: Galvanized steel

### Stock-Pulleys with Standard dimensions are marked in blue (\* over $z = 18$ ).

In-between widths and larger widths as well as other hub dimensions are available.

- $z$  = Number of teeth
- $d_k$  = Outside diameter
- $d_0$  = Pitch circle diameter
- $d_B$  = Flange diameter
- $d_N$  = Hub diameter

- $l_N$  = Hub length
- $d_v$  = Pre-bore diameter
- $d_{max}$  = max. bore diameter without keyway for flanged timing pulleys; no hub at maximum pre-bore

z	Hub			Bore		
	$d_k$ [mm]	$d_0$ [mm]	$d_B$ [mm]	$d_N \times l_N$ [mm]	$d_v$ [mm]	$d_{max}$ [mm]
12	36,35	38,20	42	28x10	6H7	24
13	39,55	41,38	45	28x10	6H7	26
14	42,70	44,56	48	32x10	8H7	30
15	45,90	47,75	52	32x10	8H7	34
16	49,10	50,93	55	35x10	8H7	36
17	52,25	54,11	58	35x10	8H7	40
18	55,45	57,30	61	40x10	10H7	44
19	58,65	60,48	64	44x10	10H7	46

z	Hub			Bore		
	$d_k$ [mm]	$d_0$ [mm]	$d_B$ [mm]	$d_N \times l_N$ [mm]	$d_v$ [mm]	$d_{max}$ [mm]
20	61,80	63,66	68	46x10	12H7	50
21	65,00	66,85	72	46x10	12H7	52
22	68,20	70,03	74	50x10	12H7	56
23	71,35	73,21	76	50x10	12H7	60
24	74,55	76,39	80	58x10	12H7	62
25	77,75	79,58	84	60x10	12H7	66
26	80,90	82,76	86	60x10	12H7	68
27	84,10	85,94	90	60x10	12H7	72
28	87,25	89,13	93	60x10	12H7	76
29	90,45	92,31	96	60x10	12H7	78
30	93,65	95,49	99	60x10	12H7	82
31	96,80	98,68	102	60x10	12H7	84
32	100,00	101,86	106	65x10	12H7	88
33	103,20	105,04	109	65x10	12H7	88
34	106,35	108,23	112	65x10	12H7	92

## T 10

z	Hub			Bore		
	d <sub>K</sub> [mm]	d <sub>0</sub> [mm]	d <sub>B</sub> [mm]	d <sub>N</sub> x l <sub>N</sub> [mm]	d <sub>V</sub> [mm]	d <sub>max</sub> [mm]
35	109,55	111,41	115	65x10	16H7	96
36	112,75	114,59	118	70x10	16H7	98
37	115,90	117,77	121	70x10	16H7	101
38	119,10	120,96	125	70x10	16H7	104
39	122,30	124,14	128	70x10	16H7	106
40	125,45	127,32	131	80x10	16H7	110
41	128,65	130,51	134	80x10	16H7	110
42	131,85	133,69	137	80x10	16H7	112
43	135,00	136,87	140	80x10	16H7	114
44	138,20	140,06	144	90x10	16H7	118
45	141,40	143,24	147	90x10	16H7	120
46	144,50	146,42	150	90x10	16H7	122
47	147,75	149,61	153	90x10	16H7	122
48	150,95	152,79	156	95x10	16H7	124
49	154,10	155,97	160	95x10	16H7	126
50	157,30	159,15	163	95x10	16H7	130
51	160,50	162,34	166	95x10	16H7	134
52	163,65	165,52	169	95x10	16H7	136
53	166,85	168,70	172	95x10	16H7	140
54	170,05	171,89	176	110x10	16H7	144
55	173,20	175,07	179	110x10	16H7	146
56	176,40	178,25	182	110x10	16H7	150
57	179,60	181,44	185	110x10	16H7	152
58	182,75	184,62	188	110x10	16H7	156
59	185,95	187,80	191	110x10	16H7	160
60	189,15	190,99	195	110x10	16H7	162
61	192,30	194,17	198	110x10	16H7	164
62	195,50	197,35	201	110x10	16H7	166
63	198,70	200,54	204	140x10	16H7	170
64	201,85	203,72	207	140x10	16H7	171
65	205,05	206,90	210	140x10	16H7	174
66	208,25	210,08	214	140x10	16H7	175
67	211,40	213,27	217	140x10	16H7	177
68	214,60	216,45	220	140x10	16H7	181
69	217,80	219,63	223	140x10	16H7	185
70	220,95	222,82	226	140x10	16H7	187
71	224,15	226,00	230	140x10	16H7	191
72	227,35	229,18	233	140x10	16H7	193
73	230,50	232,37	236	140x10	20H7	197
74	233,70	235,55	239	140x10	20H7	201

z	Hub			Bore		
	d <sub>K</sub> [mm]	d <sub>0</sub> [mm]	d <sub>B</sub> [mm]	d <sub>N</sub> x l <sub>N</sub> [mm]	d <sub>V</sub> [mm]	d <sub>max</sub> [mm]
75	236,90	238,73	242	140x10	20H7	203
76	240,05	241,92	246	140x10	20H7	207
77	243,25	245,10	249	160x10	20H7	209
78	246,40	248,28	252	160x10	20H7	213
79	249,60	251,46	255	160x10	20H7	215
80	252,80	254,65	258	160x10	20H7	219
81	255,95	257,83	262	160x10	20H7	223
82	259,15	261,01	265	160x10	20H7	225
83	262,35	264,20	268	160x10	20H7	229
84	265,50	267,38	271	160x10	20H7	231
85	268,70	270,56	274	160x10	20H7	235
86	271,90	273,75	277	160x10	20H7	239
87	275,05	276,93	281	160x10	20H7	241
88	278,25	280,11	284	160x10	20H7	245
89	281,45	283,30	287	160x10	20H7	247
90	284,60	286,48	290	160x10	20H7	251
91	287,80	289,66	293	160x10	20H7	255
92	291,00	292,85	296	160x10	20H7	257
93	294,15	296,03	299	160x10	20H7	261
94	297,35	299,21	302	160x10	20H7	263
95	300,55	302,39	306	160x10	24H7	267
96	303,70	305,58	310	180x10	24H7	269
97	306,90	308,76	312	180x10	24H7	273
98	310,10	311,94	315	180x10	24H7	279
99	313,25	315,13	318	180x10	24H7	283
100	316,45	318,31	322	180x10	24H7	285
101	319,65	321,49	325	180x10	24H7	289
102	322,80	324,68	329	180x10	24H7	293
103	326,00	327,86	332	180x10	24H7	295
104	329,20	331,04	335	180x10	24H7	299
105	332,35	334,23	338	180x10	24H7	301
106	335,55	337,41	341	180x10	24H7	305
107	338,75	340,59	344	180x10	24H7	309
108	341,90	343,77	348	180x10	24H7	311
109	345,10	346,96	351	180x10	24H7	315
110	348,30	350,14	354	180x10	24H7	317
111	351,45	353,32	357	180x10	24H7	321
112	354,65	356,51	360	180x10	24H7	323
113	357,85	359,69	363	180x10	24H7	327
114	361,00	362,87	367	180x10	24H7	330

# Timing pulleys T-Profile

## T 20

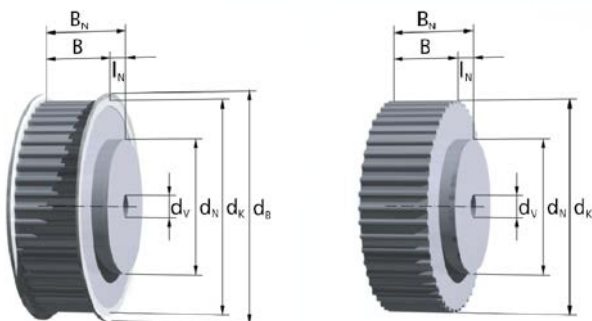

**Order example:**

Pulley AL 70 T 20 / 50 - 0 Hub 140x10; d<sub>v</sub>  
 Material \_\_\_\_\_  
 Total width B<sub>N</sub> \_\_\_\_\_  
 Type / pitch \_\_\_\_\_  
 Number of teeth \_\_\_\_\_  
 Number of flanges \_\_\_\_\_  
 Hub dimension d<sub>N</sub> x I<sub>N</sub> \_\_\_\_\_

Note for part code:

d<sub>v</sub> = Diameter pre-drilled.

Refer to page 14 for further ordering information.

Belt width	b [mm]	16	25	32	50	75	100
Pulley width	B [mm]	23	32	40	60	85	110
Total width	B <sub>N</sub> [mm]	33	42	50	70	95	120

**Materials:**

Pulley: AlCu4MgSi, RoHS-conformant  
 Flange: Galvanized steel, screwed

**In-between widths and larger widths as well as other hub dimensions are available.**

- z = Number of teeth
- d<sub>k</sub> = Outside diameter
- d<sub>0</sub> = Pitch circle diameter
- d<sub>B</sub> = Flange diameter
- d<sub>N</sub> = Hub diameter

- I<sub>N</sub> = Hub length
- d<sub>v</sub> = Pre-bore diameter
- d<sub>max</sub> = max. bore diameter without keyway for flanged timing pulleys; no hub at maximum pre-bore

z	d <sub>k</sub> [mm]	d <sub>0</sub> [mm]	d <sub>B</sub> [mm]	Hub d <sub>N</sub> x I <sub>N</sub> [mm]	Bore d <sub>v</sub> [mm]	d <sub>max</sub> [mm]
15	92,65	95,49	102	60x10	12H7	67
16	99,00	101,86	109	70x10	12H7	74
17	105,35	108,23	115	70x10	12H7	80
18	111,75	114,59	121	70x10	12H7	86
19	118,10	120,96	128	80x10	12H7	93
20	124,45	127,32	134	90x10	16H7	100
21	130,85	133,69	140	90x10	16H7	105
22	137,20	140,06	147	90x10	16H7	112
23	143,55	146,42	153	90x10	16H7	118
24	149,95	152,79	160	95x10	16H7	125
25	156,30	159,15	166	95x10	16H7	131
26	162,65	165,52	172	95x10	16H7	137
27	169,05	171,89	179	110x10	16H7	144
28	175,40	178,25	185	110x10	16H7	150
29	181,75	184,62	192	110x10	16H7	156

z	d <sub>k</sub> [mm]	d <sub>0</sub> [mm]	d <sub>B</sub> [mm]	Hub d <sub>N</sub> x I <sub>N</sub> [mm]	Bore d <sub>v</sub> [mm]	d <sub>max</sub> [mm]
30	188,15	190,99	198	110x10	16H7	163
31	194,50	197,35	204	110x10	16H7	169
32	200,85	203,72	210	110x10	16H7	175
33	207,25	210,08	217	110x10	16H7	182
34	213,60	216,45	223	110x10	16H7	188
35	219,95	222,82	229	110x10	16H7	195
36	226,35	229,18	236	110x10	18H7	201
37	232,70	235,55	242	110x10	18H7	207
38	239,05	241,92	249	110x10	18H7	214
39	245,40	248,28	255	110x10	18H7	220
40	251,80	254,65	261	110x10	18H7	226
41	258,15	261,01	268	130x10	18H7	233
42	264,50	267,38	274	130x10	18H7	239
43	270,90	273,75	280	130x10	18H7	245
44	277,25	280,11	287	130x10	18H7	252



## T 20

z	Hub			Bore		
	d <sub>K</sub> [mm]	d <sub>0</sub> [mm]	d <sub>B</sub> [mm]	d <sub>N</sub> x l <sub>N</sub> [mm]	d <sub>V</sub> [mm]	d <sub>max</sub> [mm]
45	283,60	286,48	293	130x10	18H7	258
46	290,00	292,85	300	130x10	18H7	265
47	296,35	299,21	306	130x10	18H7	271
48	302,70	305,58	312	130x10	18H7	278
49	309,10	311,94	319	130x10	20H7	284
50	315,45	318,31	325	140x10	20H7	290
51	321,80	324,68	331	140x10	20H7	296
52	328,20	331,04	338	140x10	20H7	303
53	334,55	337,41	344	140x10	20H7	310
54	340,90	343,77	350	140x10	20H7	315
55	347,30	350,14	357	140x10	20H7	322
56	353,65	356,51	363	140x10	20H7	328
57	360,00	362,87	370	140x10	20H7	335
58	366,40	369,24	376	140x10	20H7	341
59	372,75	375,61	382	140x10	20H7	347
60	379,10	381,97	389	140x10	20H7	354
61	385,50	388,34	395	140x10	20H7	360
62	391,85	394,70	401	140x10	20H7	366
63	398,20	401,07	408	140x10	20H7	373
64	404,55	407,44	414	140x10	20H7	379
65	410,95	413,80	420	140x10	20H7	385
66	417,30	420,17	427	140x10	20H7	392
67	423,65	426,54	433	140x10	20H7	398
68	430,05	432,90	440	140x10	20H7	405
69	436,40	439,27	446	140x10	20H7	406
70	442,75	445,63	452	140x10	20H7	412
71	449,15	452,00	459	140x10	20H7	419
72	455,50	458,37	465	140x10	20H7	425
73	461,85	464,73	471	160x10	30H7	431
74	468,25	471,10	478	160x10	30H7	438
75	474,60	477,46	484	160x10	30H7	444
76	480,95	483,83	490	160x10	30H7	450
77	487,35	490,20	497	160x10	30H7	457
78	493,70	496,56	503	160x10	30H7	463
79	500,05	502,93	510	160x10	30H7	470

z	Hub			Bore		
	d <sub>K</sub> [mm]	d <sub>0</sub> [mm]	d <sub>B</sub> [mm]	d <sub>N</sub> x l <sub>N</sub> [mm]	d <sub>V</sub> [mm]	d <sub>max</sub> [mm]
80	506,45	509,30	516	-	30H7	476
81	512,80	515,66	522	-	30H7	482
82	519,15	522,03	529	-	30H7	489
83	525,55	528,39	535	-	30H7	495
84	531,90	534,76	541	-	30H7	501
85	538,25	541,13	548	-	30H7	503
86	544,65	547,49	554	-	30H7	509
87	551,00	553,86	561	-	30H7	516
88	557,35	560,23	567	-	30H7	522
89	563,70	566,59	573	-	30H7	528
90	570,10	572,96	580	-	30H7	535
91	576,45	579,32	586	-	30H7	541
92	582,80	585,69	592	-	30H7	548
93	589,20	592,06	599	-	30H7	554
94	595,55	598,42	605	-	30H7	560
95	601,90	604,79	611	-	40H7	566
96	608,30	611,15	618	-	40H7	573
97	614,65	617,52	624	-	40H7	579
98	621,00	623,89	631	-	40H7	586
99	627,40	630,25	637	-	40H7	592
100	633,75	636,62	643	-	40H7	598
101	640,10	642,99	650	-	40H7	605
102	646,50	649,35	656	-	40H7	611
103	652,85	655,72	662	-	40H7	617
104	659,20	662,08	669	-	40H7	624
105	665,60	668,45	675	-	40H7	630
106	671,95	674,82	681	-	40H7	636
107	678,30	681,18	688	-	40H7	643
108	684,70	687,55	694	-	40H7	649
109	691,05	693,92	701	-	40H7	656
110	697,40	700,28	707	-	40H7	662
111	703,80	706,65	713	-	40H7	663
112	710,15	713,01	720	-	40H7	670
113	716,50	719,38	726	-	40H7	676
114	722,85	725,75	732	-	40H7	682

# Timing pulleys Imperial-Profiles

## M / MXL / Mini-Pitch (T 2,032)

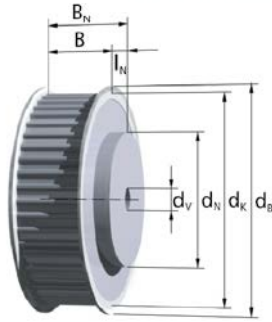

Stock pulleys over  
z = 24 with flanges

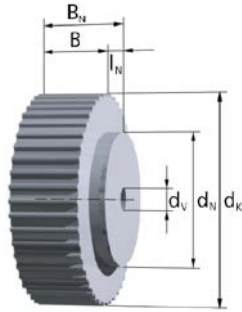

Stock pulleys up to  
z = 20 without flanges

### Order example:

Pulley Al 16 M / 32 - 2 Hub 14x6; dv  
 Material \_\_\_\_\_  
 Total width B<sub>N</sub> \_\_\_\_\_  
 Type / pitch \_\_\_\_\_  
 Number of teeth \_\_\_\_\_  
 Number of flanges \_\_\_\_\_  
 Hub dimension d<sub>N</sub> x l<sub>N</sub> \_\_\_\_\_

Note for part code:

dv = Diameter pre-drilled.

Refer to page 14 for further ordering information.

Belt width	b [mm]	4	6	10
Pulley width	B [mm]	8	10	14
Total width	B <sub>N</sub> [mm]	14	16	20

### Material:

AlCu4MgSi, RoHS-conformant

The stock pulleys with standard dimensioning are marked in blue (\*\*over z = 18).

In-between widths and larger widths as well as other hub dimensions are available.

- z = Number of teeth
- d<sub>k</sub> = Outside diameter
- d<sub>o</sub> = Pitch circle diameter
- d<sub>B</sub> = Flange diameter
- d<sub>N</sub> = Hub diameter

- l<sub>N</sub> = Hub length
- d<sub>v</sub> = Pre-bore diameter
- d<sub>max</sub> = max. bore diameter without keyway for flanged timing pulleys; no hub at maximum pre-bore

z	d <sub>k</sub> [mm]	d <sub>o</sub> [mm]	d <sub>B</sub> [mm]	Hub d <sub>N</sub> x l <sub>N</sub> [mm]	Bore d <sub>v</sub> [mm]	d <sub>max</sub> [mm]
15	9,19	9,70	13	-	3H7	3,5
16	9,84	10,35	13	-	3H7	3,5
17	10,49	11,00	14	-	3H7	4
18	11,13	11,64	14	-	3H7	4
19	11,78	12,29	15	-	3H7	5
20	12,43	12,94	15	-	3H7	5
21	13,07	13,58	16	-	3H7	6
22	13,72	14,23	16	-	3H7	6
23	14,37	14,88	18	-	3H7	8
24	15,02	15,52	18	10x6	3H7	8
25	15,66	16,17	19	10x6	3H7	9
26	16,31	16,82	19	10x6	3H7	9
27	16,96	17,46	20	10x6	3H7	10
28	17,60	18,11	20	10x6	3H7	10
29	18,25	18,76	22	10x6	3H7	12

z	d <sub>k</sub> [mm]	d <sub>o</sub> [mm]	d <sub>B</sub> [mm]	Hub d <sub>N</sub> x l <sub>N</sub> [mm]	Bore d <sub>v</sub> [mm]	d <sub>max</sub> [mm]
30	18,90	19,40	22	10x6	3H7	12
31	19,54	20,05	22	10x6	3H7	12
32	20,19	20,70	24	14x6	3H7	13
33	20,83	21,34	24	14x6	3H7	13
34	21,48	21,99	24	14x6	3H7	13
35	22,13	22,64	25	14x6	3H7	14
36	22,78	23,29	26	14x6	3H7	14
37	23,42	23,93	26	14x6	3H7	14
38	24,07	24,58	28	14x6	3H7	16
39	24,72	25,23	28	14x6	3H7	16
40	25,36	25,87	28	14x6	3H7	16
41	26,01	26,52	30	14x6	3H7	18
42	26,66	27,17	30	14x6	3H7	18
43	27,30	27,81	30	14x6	3H7	18
44	27,95	28,46	32	14x6	3H7	18

## M / MXL / Mini-Pitch (T 2,032)

z	Hub			Bore		
	d <sub>K</sub> [mm]	d <sub>0</sub> [mm]	d <sub>B</sub> [mm]	d <sub>N</sub> x l <sub>N</sub> [mm]	d <sub>V</sub> [mm]	d <sub>max</sub> [mm]
45	28,60	29,11	32	14x6	3H7	18
46	29,24	29,75	32	14x6	3H7	18
47	29,89	30,40	35	14x6	3H7	21
48	30,54	31,05	35	20x6	4H7	21
49	31,18	31,69	35	20x6	4H7	21
50	31,83	32,34	35	20x6	4H7	21
51	32,48	32,99	36	20x6	4H7	21
52	33,12	33,63	36	20x6	4H7	21
53	33,77	34,28	36	20x6	4H7	21
54	34,42	34,93	40	22x6	4H7	24
55	35,06	35,57	40	22x6	4H7	24
56	35,71	36,22	40	22x6	4H7	24
57	36,36	36,87	42	22x6	4H7	26
58	37,00	37,51	42	22x6	4H7	26
59	37,65	38,16	42	22x6	4H7	26
60	38,30	38,81	42	22x6	4H7	26
61	38,95	39,46	42	26x6	4H7	26
62	39,59	40,10	45	26x6	4H7	28
63	40,24	40,75	45	26x6	4H7	28
64	40,89	41,40	45	26x6	4H7	28
65	41,53	42,04	45	26x6	6H7	28
66	42,18	42,69	47	26x6	6H7	33
67	42,83	43,34	47	26x6	6H7	33
68	43,47	43,98	47	26x6	6H7	33
69	44,12	44,63	47	26x6	6H7	33
70	44,77	45,28	50	26x6	6H7	36
71	45,41	45,92	50	26x6	6H7	36
72	46,06	46,57	50	26x6	6H7	36
73	46,71	47,22	50	34x6	6H7	36
74	47,35	47,86	53	34x6	6H7	36
75	48,00	48,51	53	34x6	6H7	36
76	48,65	49,16	53	34x6	6H7	36
77	49,29	49,80	53	34x6	6H7	36
78	49,94	50,45	55	34x6	6H7	41
79	50,59	51,10	55	34x6	6H7	41

z	Hub			Bore		
	d <sub>K</sub> [mm]	d <sub>0</sub> [mm]	d <sub>B</sub> [mm]	d <sub>N</sub> x l <sub>N</sub> [mm]	d <sub>V</sub> [mm]	d <sub>max</sub> [mm]
80	51,23	51,74	55	34x6	6H7	41
81	51,88	52,39	56	34x6	6H7	42
82	52,53	53,04	56	34x6	6H7	42
83	53,17	53,68	58	34x6	6H7	44
84	53,82	54,33	58	34x6	6H7	44
85	54,47	54,98	60	34x6	6H7	46
86	55,12	55,63	60	34x6	6H7	46
87	55,76	56,27	61	34x6	8H7	47
88	56,41	56,92	61	34x6	8H7	47
89	57,06	57,57	62	34x6	8H7	48
90	57,70	58,21	62	34x6	8H7	48
91	58,35	58,86	64	38x6	8H7	50
92	59,00	59,51	64	38x6	8H7	50
93	59,64	60,15	64	38x6	8H7	50
94	60,29	60,80	66	38x6	8H7	51
95	60,94	61,45	66	38x6	8H7	51
96	61,58	62,09	66	38x6	8H7	52
97	62,23	62,74	68	38x6	8H7	53
98	62,88	63,39	68	38x6	8H7	54
99	63,52	64,03	70	38x6	8H7	56
100	64,17	64,68	70	38x6	8H7	56
101	64,82	65,33	70	38x6	8H7	56
102	65,46	65,97	72	38x6	8H7	58
103	66,11	66,62	72	38x6	8H7	58
104	66,76	67,27	72	38x6	8H7	58
105	67,40	67,91	72	38x6	8H7	58
106	68,05	68,56	74	38x6	8H7	60
107	68,70	69,21	74	38x6	8H7	60
108	69,35	69,86	74	38x6	8H7	60
109	69,99	70,50	75	38x6	8H7	61
110	70,64	71,15	75	38x6	8H7	61
111	71,29	71,80	76	38x6	8H7	62
112	71,93	72,44	78	38x6	8H7	63
113	72,58	73,09	78	40x6	10H7	64
114	73,23	73,74	78	40x6	10H7	64

# Timing pulleys Imperial-Profile

**XL** (T 1,5")

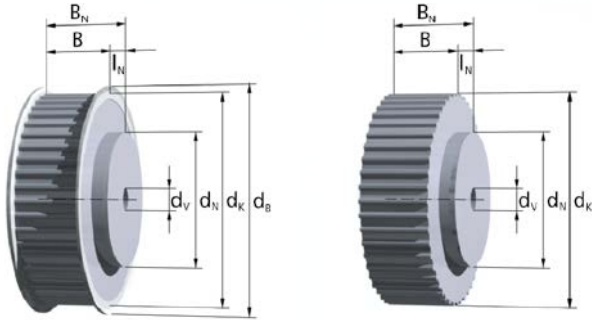

**Order example:**

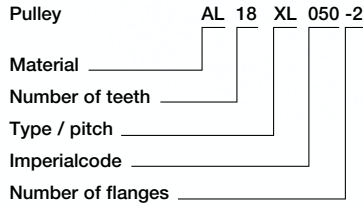

Refer to page 14 for further ordering information.

**Material:**

AlCu4MgSi, RoHS-conformant

Imperialcode		025	031	037	050	075	100	150	200	300
Belt width	b [mm]	6,35	7,94	9,53	12,7	19,1	25,4	38,1	50,8	76,2
Pulley width	B [mm]	12	14	16	19	25	32	44	59	84
Total width	B <sub>N</sub> [mm]									B <sub>N</sub> = B+l <sub>N</sub>

**In-between widths and larger widths as well as other hub dimensions are available.**

- z = Number of teeth
- d<sub>k</sub> = Outside diameter
- d<sub>0</sub> = Pitch circle diameter
- d<sub>B</sub> = Flange diameter
- d<sub>N</sub> = Hub diameter

- l<sub>N</sub> = Hub length
- d<sub>v</sub> = Pre-bore diameter
- d<sub>max</sub> = max. bore diameter without keyway for flanged timing pulleys; no hub at maximum pre-bore

z	d <sub>k</sub> [mm]	d <sub>0</sub> [mm]	d <sub>B</sub> [mm]	Hub d <sub>N</sub> x l <sub>N</sub> [mm]	Bore d <sub>v</sub> [mm]	d <sub>max</sub> [mm]
10	15,66	16,17	20	9,5x5,3	4H7	7
11	17,28	17,79	22	9,5x5,3	4H7	8
12	18,90	19,40	23	12,7x5,3	4H7	11
13	20,51	21,02	25	14,3x5,3	4H7	13
14	22,13	22,64	28	14,3x5,3	6H7	14
15	23,75	24,26	28	15,9x5,3	6H7	14
16	25,36	25,87	30	17,5x5,3	6H7	18
17	26,98	27,49	32	20,6x5,3	6H7	18
18	28,60	29,11	34	20,6x5,3	6H7	21
19	30,21	30,72	35	23,8x8,1	6H7	22

z	d <sub>k</sub> [mm]	d <sub>0</sub> [mm]	d <sub>B</sub> [mm]	Hub d <sub>N</sub> x l <sub>N</sub> [mm]	Bore d <sub>v</sub> [mm]	d <sub>max</sub> [mm]
20	31,83	32,34	36	23,8x8,1	6H7	23
21	33,45	33,96	39	23,8x8,1	6H7	25
22	35,07	35,57	40	25,4x8,1	6H7	26
23	36,86	37,19	42	27x8,1	6H7	26
24	38,30	38,81	43	27x8,1	6H7	27
25	39,92	40,43	45	30x8,1	6H7	29
26	41,53	42,04	47	30x8,1	6H7	31
27	43,15	43,66	48	30x8,1	6H7	32
28	44,77	45,28	50	30x8,1	6H7	34
29	46,38	46,89	52	34x8,1	6H7	36
30	48,00	48,51	53	34x8,1	6H7	37
31	49,62	50,13	55	38x12,1	8H7	39
32	51,24	51,74	56	38x12,1	8H7	40
33	52,85	53,36	58	38x12,1	8H7	42
34	54,47	54,98	60	38x12,1	8H7	44



XL (T 1,5<sup>4</sup>)

z	Hub			Bore	
	d <sub>K</sub> [mm]	d <sub>0</sub> [mm]	d <sub>B</sub> [mm]	d <sub>N</sub> x l <sub>N</sub> [mm]	d <sub>V</sub> d <sub>max</sub> [mm] [mm]
35	56,09	56,60	61	38x12,1	8H7 46
36	57,70	58,21	62	38x12,1	8H7 46
37	59,32	59,83	64	38x12,1	8H7 48
38	60,94	61,45	66	38x12,1	8H7 48
39	62,55	63,06	68	38x12,1	8H7 50
40	64,17	64,68	70	38x12,1	8H7 54
41	65,79	66,30	72	38x12,1	8H7 54
42	67,40	67,91	74	38x12,1	8H7 54
43	69,02	69,53	75	38x12,1	8H7 56
44	70,64	71,15	76	38x12,1	8H7 57
45	72,26	72,77	78	38x12,1	8H7 60
46	73,87	74,38	80	38x12,1	8H7 62
47	75,49	76,00	82	38x12,1	8H7 62
48	77,11	77,62	82	38x12,1	8H7 64
49	78,72	79,23	84	38x12,1	8H7 66
50	80,34	80,85	86	38x12,1	8H7 68
51	81,96	82,47	88	38x12,1	8H7 70
52	83,57	84,08	90	38x12,1	8H7 72
53	85,19	85,70	90	38x12,1	8H7 72
54	86,81	87,32	93	38x12,1	8H7 73
55	88,43	88,94	93	38x12,1	8H7 75
56	90,04	90,55	96	38x12,1	8H7 78
57	91,66	92,17	96	38x12,1	8H7 79
58	93,28	93,79	99	38x12,1	8H7 79
59	94,89	95,40	100	38x12,1	8H7 80
60	96,51	97,02	102	38x12,1	8H7 82
61	98,13	98,64	104	38x12,1	8H7 84
62	99,74	100,25	106	38x12,1	8H7 86
63	101,36	101,87	106	38x12,1	8H7 86
64	102,98	103,49	108	38x12,1	8H7 89
65	104,60	105,11	110	38x12,1	8H7 89
66	106,21	106,72	112	38x12,1	8H7 92
67	107,83	108,34	112	38x12,1	8H7 95
68	109,45	109,96	115	38x12,1	8H7 95
69	111,06	111,57	117	38x12,1	8H7 97
70	112,68	113,19	118	38x12,1	8H7 98
71	114,30	114,81	121	38x12,1	8H7 98
72	115,92	116,43	121	38x12,1	8H7 101
73	117,53	118,04	123	45x12,1	10H7 103
74	119,15	119,66	125	45x12,1	10H7 105

z	Hub			Bore	
	d <sub>K</sub> [mm]	d <sub>0</sub> [mm]	d <sub>B</sub> [mm]	d <sub>N</sub> x l <sub>N</sub> [mm]	d <sub>V</sub> d <sub>max</sub> [mm] [mm]
75	120,77	121,28	128	45x12,1	10H7 108
76	122,38	122,89	128	45x12,1	10H7 108
77	124,00	124,51	131	45x12,1	10H7 111
78	125,62	126,13	131	45x12,1	10H7 111
79	127,23	127,74	134	45x12,1	10H7 110
80	128,85	129,36	134	45x12,1	10H7 110
81	130,47	130,98	137	45x12,1	10H7 113
82	132,08	132,60	137	45x12,1	10H7 113
83	133,70	134,21	140	45x12,1	10H7 116
84	135,32	135,83	140	45x12,1	10H7 116
85	136,94	137,45	142	45x12,1	10H7 120
86	138,55	139,06	144	45x12,1	10H7 120
87	140,17	140,68	147	45x12,1	10H7 123
88	141,79	142,30	147	45x12,1	10H7 123
89	143,40	143,91	150	45x12,1	10H7 126
90	145,02	145,53	150	45x12,1	10H7 126
91	146,64	147,15	153	45x12,1	10H7 129
92	148,25	148,77	153	45x12,1	10H7 129
93	149,87	150,38	156	45x12,1	10H7 132
94	151,49	152,00	158	45x12,1	10H7 134
95	153,11	153,62	158	55x12,1	12H7 134
96	154,72	155,23	160	55x12,1	12H7 136
97	156,34	156,85	163	55x12,1	12H7 139
98	157,96	158,47	163	55x12,1	12H7 142
99	159,57	160,08	166	55x12,1	12H7 142
100	161,19	161,70	166	55x12,1	12H7 145
101	162,81	163,32	169	55x12,1	12H7 145
102	164,43	164,94	169	55x12,1	12H7 147
103	166,04	166,55	172	55x12,1	12H7 147
104	167,66	168,17	174	55x12,1	12H7 150
105	169,28	169,79	174	55x12,1	12H7 150
106	170,89	171,40	176	55x12,1	12H7 152
107	172,51	173,02	179	55x12,1	12H7 155
108	174,13	174,64	179	55x12,1	12H7 155
109	175,74	176,25	182	55x12,1	12H7 158
110	177,36	177,87	182	55x12,1	12H7 158
111	178,98	179,49	185	55x12,1	12H7 161
112	180,60	181,11	185	55x12,1	12H7 164
113	182,21	182,72	188	55x12,1	12H7 164
114	183,83	184,34	191	55x12,1	12H7 167

# Timing pulleys Imperial-Profile

L (T 3/8")

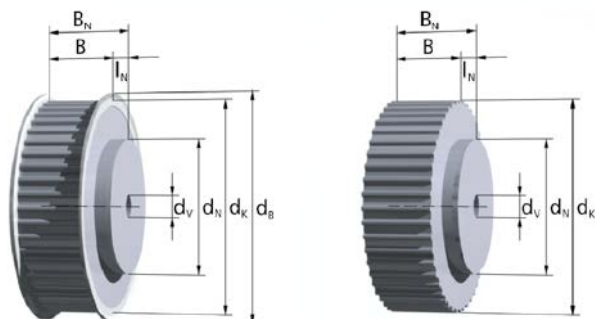

**Order example:**

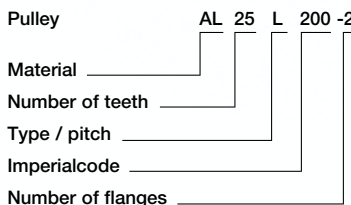

Refer to page 14 for further ordering information.

**Material:**

AlCu4MgSi, RoHS-conformant

Imperialcode		037	050	075	100	150	200	300	400
Belt width	b [mm]	9,53	12,7	19,1	25,4	38,1	50,8	76,2	101,6
Pulley width	B [mm]	16	19	25	32	44	59	84	111
Total width	B <sub>N</sub> [mm]				B <sub>N</sub> = B + l <sub>N</sub>				

In-between widths and larger widths as well as other hub dimensions are available.

- z = Number of teeth
- d<sub>k</sub> = Outside diameter
- d<sub>0</sub> = Pitch circle diameter
- d<sub>B</sub> = Flange diameter
- d<sub>N</sub> = Hub diameter

- l<sub>N</sub> = Hub length
- d<sub>v</sub> = Pre-bore diameter
- d<sub>max</sub> = max. bore diameter without keyway for flanged timing pulleys; no hub at maximum pre-bore

z	d <sub>k</sub> [mm]	d <sub>0</sub> [mm]	d <sub>B</sub> [mm]	Hub d <sub>N</sub> x l <sub>N</sub> [mm]	Bore d <sub>v</sub> [mm]	d <sub>max</sub> [mm]
15	44,72	45,48	50	36x7	8H7	34
16	47,75	48,51	55	38x7	8H7	36
17	50,78	51,54	56	40x7	10H7	38
18	53,81	54,57	60	40x7	10H7	41
19	56,84	57,61	62	40x7	10H7	44
20	59,88	60,64	66	46x7	10H7	47
21	62,91	63,67	68	46x7	10H7	50
22	65,94	66,70	72	50x7	10H7	52
23	68,97	69,73	74	50x7	12H7	54
24	72,00	72,77	78	50x7	12H7	58
25	75,04	75,80	82	50x7	12H7	62
26	78,07	78,83	84	50x7	12H7	62
27	81,10	81,86	88	50x7	12H7	66
28	84,13	84,89	90	50x7	12H7	70
29	87,16	87,93	93	50x7	12H7	73

z	d <sub>k</sub> [mm]	d <sub>0</sub> [mm]	d <sub>B</sub> [mm]	Hub d <sub>N</sub> x l <sub>N</sub> [mm]	Bore d <sub>v</sub> [mm]	d <sub>max</sub> [mm]
30	90,20	90,96	96	50x7	12H7	77
31	93,23	93,99	99	50x7	12H7	79
32	96,26	97,02	102	50x7	12H7	81
33	99,29	100,05	106	50x7	12H7	86
34	102,32	103,08	108	50x7	12H7	88
35	105,36	106,12	110	50x7	12H7	90
36	108,39	109,15	115	50x7	12H7	95
37	111,42	112,18	117	50x7	12H7	98
38	114,45	115,21	121	50x7	12H7	100
39	117,48	118,24	123	50x7	12H7	102
40	120,51	121,28	128	50x7	12H7	104
41	123,55	124,31	131	50x7	12H7	107
42	126,58	127,34	134	50x7	12H7	109
43	129,61	130,37	137	50x7	12H7	111
44	132,64	133,40	140	50x7	12H7	115

L (T 3/8")

z	d <sub>K</sub> [mm]	d <sub>0</sub> [mm]	d <sub>B</sub> [mm]	Hub		Bore	
				d <sub>N</sub> x l <sub>N</sub> [mm]	d <sub>V</sub> [mm]	d <sub>max</sub> [mm]	
45	135,68	136,44	142	50x7	12H7	118	
46	138,71	139,47	144	50x7	12H7	123	
47	141,74	142,50	147	50x7	12H7	126	
48	144,77	145,53	150	50x7	12H7	131	
49	147,80	148,56	153	50x9	15H7	131	
50	150,83	151,60	158	50x9	15H7	134	
51	153,87	154,63	160	50x9	15H7	139	
52	156,90	157,66	163	50x9	15H7	142	
53	159,93	160,69	166	50x9	15H7	144	
54	162,96	163,72	169	50x9	15H7	147	
55	165,99	166,75	172	50x9	15H7	149	
56	169,03	169,79	174	50x9	15H7	152	
57	172,06	172,82	179	50x9	15H7	157	
58	175,09	175,85	182	50x9	15H7	160	
59	178,12	178,88	185	50x9	15H7	163	
60	181,15	181,91	188	50x9	15H7	166	
61	184,19	184,95	191	50x9	15H7	167	
62	187,22	187,98	195	50x9	15H7	167	
63	190,25	191,01	198	50x9	15H7	173	
64	193,28	194,04	201	50x9	15H7	176	
65	196,31	197,07	204	50x9	15H7	180	
66	199,35	200,11	207	50x9	15H7	180	
67	202,38	203,14	210	50x9	15H7	186	
68	205,41	206,17	210	50x9	15H7	186	
69	208,44	209,20	214	50x9	15H7	190	
70	211,47	212,23	217	50x9	15H7	190	
71	214,50	215,27	220	50x9	15H7	196	
72	217,53	218,30	223	50x9	15H7	199	
73	220,57	221,33	226	50x9	15H7	202	
74	223,60	224,36	230	50x9	15H7	206	
75	226,63	227,39	233	50x9	15H7	208	
76	229,66	230,42	236	50x9	15H7	212	
77	232,70	233,46	239	50x9	15H7	215	
78	235,73	236,49	242	50x9	15H7	218	
79	238,76	239,52	246	50x9	15H7	221	

z	d <sub>K</sub> [mm]	d <sub>0</sub> [mm]	d <sub>B</sub> [mm]	Hub		Bore	
				d <sub>N</sub> x l <sub>N</sub> [mm]	d <sub>V</sub> [mm]	d <sub>max</sub> [mm]	
80	241,79	242,55	249	50x9	15H7	222	
81	244,82	245,58	252	50x9	15H7	222	
82	247,86	248,62	255	50x9	15H7	222	
83	250,89	251,65	258	50x9	15H7	225	
84	253,92	254,68	262	50x9	15H7	234	
85	256,95	257,71	265	65x9	20H7	237	
86	259,98	260,74	268	65x9	20H7	241	
87	263,01	263,78	271	65x9	20H7	241	
88	266,05	266,81	274	65x9	20H7	244	
89	269,08	269,84	277	65x9	20H7	247	
90	272,11	272,87	277	65x9	20H7	250	
91	275,14	275,90	281	65x9	20H7	256	
92	278,17	278,93	284	65x9	20H7	260	
93	281,21	281,97	287	65x9	20H7	263	
94	284,24	285,00	290	65x9	20H7	266	
95	287,27	288,03	293	65x9	20H7	254	
96	290,30	291,06	296	65x9	20H7	257	
97	293,33	294,09	300	65x9	20H7	261	
98	296,37	297,13	302	65x9	20H7	264	
99	299,40	300,16	306	65x9	20H7	267	
100	302,43	303,19	310	75x9	24H7	270	
101	305,46	306,22	312	75x9	24H7	273	
102	308,49	309,25	315	75x9	24H7	277	
103	311,53	312,29	318	75x9	24H7	280	
104	314,56	315,32	322	75x9	24H7	280	
105	317,59	318,35	325	75x9	24H7	286	
106	320,62	321,38	329	75x9	24H7	289	
107	323,65	324,41	332	75x9	24H7	289	
108	326,68	327,45	335	75x9	24H7	293	
109	329,72	330,48	338	75x9	24H7	296	
110	332,75	333,51	341	75x9	24H7	299	
111	335,78	336,54	344	75x9	24H7	302	
112	338,81	339,57	348	75x9	24H7	305	
113	341,84	342,60	348	75x9	24H7	308	
114	344,88	345,64	351	75x9	24H7	312	

# Timing pulleys Imperial-Profile

**H** (T 1/2")

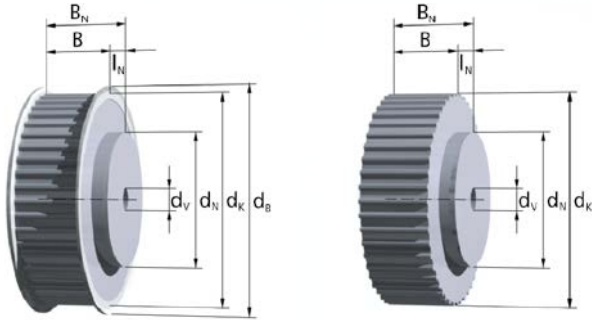

**Order example:**

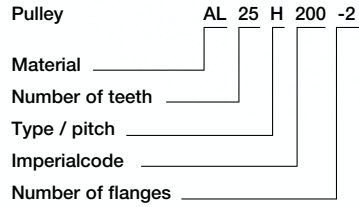

Refer to page 14 for further ordering information.

**Material:**

AlCu4MgSi, RoHS-conformant

Imperialcode		050	075	100	150	200	300	400
Belt width	b [mm]	12,7	19,1	25,4	38,1	50,8	76,2	101,6
Pulley width	B [mm]	19	25	32	44	59	84	111
Total width	BN [mm]				$B_N = B + l_N$			

**In-between widths and larger widths as well as other hub dimensions are available.**

- z = Number of teeth
- $d_k$  = Outside diameter
- $d_0$  = Pitch circle diameter
- $d_B$  = Flange diameter
- $d_N$  = Hub diameter

- $l_N$  = Hub length
- $d_v$  = Pre-bore diameter
- $d_{max}$  = max. bore diameter without keyway for flanged timing pulleys; no hub at maximum pre-bore

z	Hub			Bore		
	$d_k$ [mm]	$d_0$ [mm]	$d_B$ [mm]	$d_N \times l_N$ [mm]	$d_v$ [mm]	$d_{max}$ [mm]
14	55,23	56,60	63	40x10	12H7	42
15	59,27	60,64	66	46x10	15H7	46
16	63,31	64,68	70	46x10	15H7	51
17	67,35	68,72	75	54x10	15H7	54
18	71,39	72,77	78	54x10	15H7	56
19	75,44	76,81	82	58x10	15H7	62

z	Hub			Bore		
	$d_k$ [mm]	$d_0$ [mm]	$d_B$ [mm]	$d_N \times l_N$ [mm]	$d_v$ [mm]	$d_{max}$ [mm]
20	79,48	80,85	86	62x10	15H7	66
21	83,52	84,89	90	67x10	15H7	70
22	87,56	88,94	93	70x10	15H7	73
23	91,61	92,98	99	75x10	15H7	80
24	95,65	97,02	102	75x10	15H7	80
25	99,69	101,06	106	55x8	15H7	86
26	103,73	105,11	109	55x8	15H7	90
27	107,78	109,15	115	60x8	15H7	91
28	111,82	113,19	118	60x8	15H7	94
29	115,86	117,23	123	60x8	15H7	99
30	119,90	121,28	128	70x8	15H7	101
31	123,95	125,32	131	70x8	20H7	107
32	127,99	129,36	134	70x8	20H7	110
33	132,03	133,40	140	80x8	20H7	113
34	136,08	137,45	142	80x8	20H7	118



# H (T 1/2")

z	Hub			Bore		
	d <sub>K</sub> [mm]	d <sub>0</sub> [mm]	d <sub>B</sub> [mm]	d <sub>N</sub> x l <sub>N</sub> [mm]	d <sub>V</sub> [mm]	d <sub>max</sub> [mm]
35	140,12	141,49	147	80x8	20H7	123
36	144,16	145,53	150	80x8	20H7	126
37	148,20	149,57	156	80x8	20H7	129
38	152,25	153,62	158	80x8	20H7	134
39	156,29	157,66	163	80x8	20H7	139
40	160,33	161,70	166	80x8	20H7	142
41	164,37	165,74	172	80x8	20H7	147
42	168,42	169,79	174	80x8	20H7	150
43	172,46	173,83	179	80x8	20H7	155
44	176,50	177,87	182	80x8	20H7	158
45	180,54	181,91	188	80x8	20H7	162
46	184,59	185,96	191	80x8	20H7	167
47	188,63	190,00	195	80x8	20H7	171
48	192,67	194,04	198	80x8	20H7	174
49	196,71	198,08	204	80x11	20H7	180
50	200,76	202,13	207	80x11	20H7	183
51	204,80	206,17	212	80x11	20H7	186
52	208,84	210,21	214	80x11	20H7	176
53	212,88	214,25	220	80x11	20H7	196
54	216,93	218,30	223	80x11	20H7	199
55	220,97	222,34	226	80x11	20H7	202
56	225,01	226,38	230	80x11	20H7	206
57	229,05	230,42	236	80x11	20H7	212
58	233,10	234,47	239	80x11	20H7	215
59	237,14	238,51	242	80x11	20H7	218
60	241,18	242,55	246	80x11	20H7	222
61	245,22	246,59	252	80x11	20H7	228
62	249,27	250,64	255	80x11	20H7	231
63	253,31	254,68	258	80x11	20H7	234
64	257,35	258,72	265	80x11	20H7	241
65	261,39	262,76	268	80x11	20H7	244
66	265,44	266,81	271	80x11	20H7	244
67	269,48	270,85	277	80x11	20H7	247
68	273,52	274,89	281	80x11	20H7	250
69	277,56	278,93	284	80x11	20H7	260
70	281,61	282,98	287	80x11	20H7	269
71	285,65	287,02	293	80x11	20H7	253
72	289,69	291,06	296	80x11	20H7	259
73	293,73	295,11	300	80x11	20H7	266
74	297,78	299,15	306	80x11	20H7	269

z	Hub			Bore		
	d <sub>K</sub> [mm]	d <sub>0</sub> [mm]	d <sub>B</sub> [mm]	d <sub>N</sub> x l <sub>N</sub> [mm]	d <sub>V</sub> [mm]	d <sub>max</sub> [mm]
75	301,82	303,19	310	80x11	20H7	272
76	305,86	307,23	312	80x11	20H7	275
77	309,90	311,28	318	80x11	20H7	279
78	313,95	315,32	322	80x11	20H7	282
79	317,99	319,36	325	80x11	20H7	288
80	322,03	323,40	329	80x11	20H7	291
81	326,07	327,45	335	80x11	20H7	295
82	330,12	331,49	338	80x11	20H7	301
83	334,16	335,53	341	80x11	20H7	304
84	338,20	339,57	344	80x11	20H7	307
85	342,24	343,62	348	80x11	20H7	310
86	346,29	347,66	354	80x11	20H7	314
87	350,33	351,70	357	80x11	20H7	320
88	354,37	355,74	363	80x11	20H7	323
89	358,41	359,79	367	80x11	20H7	326
90	362,46	363,83	372	80x11	20H7	331
91	366,50	367,87	372	80x11	20H7	332
92	370,54	371,91	377	80x11	20H7	337
93	374,58	375,96	382	80x11	20H7	342
94	378,63	380,00	386	80x11	20H7	346
95	382,67	384,04	391	80x11	20H7	351
96	386,71	388,08	396	80x11	20H7	356
97	390,76	392,13	401	90x16	24H7	356
98	394,80	396,17	401	90x16	24H7	361
99	398,84	400,21	405	90x16	24H7	365
100	402,88	404,25	410	90x16	24H7	370
101	406,93	408,30	415	90x16	24H7	375
102	410,97	412,34	420	90x16	24H7	375
103	415,01	416,38	425	90x16	24H7	385
104	419,05	420,42	425	90x16	24H7	389
105	423,10	424,47	429	90x16	24H7	389
106	427,14	428,51	434	90x16	24H7	392
107	431,18	432,55	440	90x16	24H7	395
108	435,22	436,59	444	90x16	24H7	398
109	439,27	440,64	448	90x16	24H7	401
110	443,31	444,68	453	90x16	24H7	404
111	447,35	448,72	453	90x16	24H7	407
112	451,39	452,76	459	90x16	24H7	410
113	455,44	456,81	463	90x16	24H7	413
114	459,48	460,85	468	90x16	24H7	416

# Timing pulleys Imperial-Profile

**XH** (T 7/8")

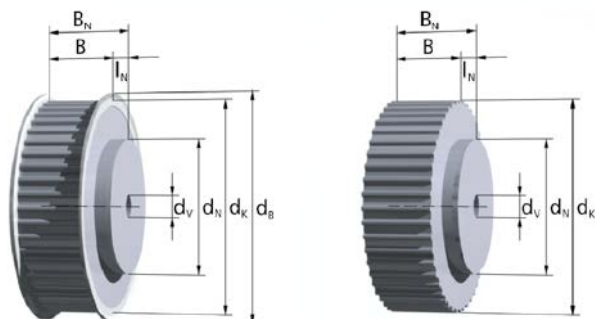

**Order example:**

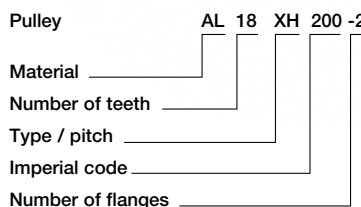

Refer to page 14 for further ordering information.

Imperialcode		200	300	400
Belt width	b [mm]	50,8	76,2	101,6
Pulley width	B [mm]	59	84	111
Total width	B <sub>N</sub> [mm]	B <sub>N</sub> = B+l <sub>N</sub>		

**Material:**

AlCu4MgSi, RoHS-conformant

**In-between widths and larger widths as well as other hub dimensions are available.**

- z = Number of teeth
- d<sub>k</sub> = Outside diameter
- d<sub>0</sub> = Pitch circle diameter
- d<sub>B</sub> = Flange diameter
- d<sub>N</sub> = Hub diameter

- l<sub>N</sub> = Hub length
- d<sub>v</sub> = Pre-bore diameter
- d<sub>max</sub> = max. bore diameter without keyway for flanged timing pulleys; no hub at maximum pre-bore

z	d <sub>k</sub> [mm]	d <sub>0</sub> [mm]	d <sub>B</sub> [mm]	Hub d <sub>N</sub> x l <sub>N</sub> [mm]	Bore d <sub>v</sub> [mm]	d <sub>max</sub> [mm]
18	124,55	127,34	134	85x18	20H7	95
19	131,62	134,41	140	95x18	20H7	102
20	138,69	141,49	147	95x18	20H7	109
21	145,77	148,56	153	110x18	20H7	116
22	152,84	155,64	160	110x18	20H7	123
23	159,92	162,71	172	125x18	20H7	130
24	166,99	169,79	179	125x18	25H7	137
25	174,07	176,86	185	140x18	25H7	144
26	181,14	183,94	192	140x18	25H7	151
27	188,22	191,01	198	120x18	25H7	158
28	195,29	198,08	204	120x18	25H7	168
29	202,37	205,16	210	120x18	25H7	172

z	d <sub>k</sub> [mm]	d <sub>0</sub> [mm]	d <sub>B</sub> [mm]	Hub d <sub>N</sub> x l <sub>N</sub> [mm]	Bore d <sub>v</sub> [mm]	d <sub>max</sub> [mm]
30	209,44	212,23	217	120x18	25H7	179
31	216,52	219,31	223	130x18	25H7	187
32	223,59	226,38	236	130x18	25H7	194
33	230,67	233,46	242	140x18	25H7	201
34	237,74	240,53	244	140x18	25H7	208
35	244,81	247,61	255	140x18	25H7	215
36	251,89	254,68	261	140x18	25H7	222
37	258,96	261,75	268	140x18	25H7	229
38	266,04	268,83	274	140x18	25H7	236
39	273,11	275,90	283	140x18	25H7	243
40	280,18	282,98	287	140x18	25H7	250
41	287,26	290,05	300	150x15	30H7	257
42	294,34	297,13	306	150x15	30H7	264
43	301,41	304,20	312	150x15	30H7	271
44	308,48	311,28	319	150x15	30H7	278

## XH (T 7/8")

z	d <sub>K</sub> [mm]	d <sub>0</sub> [mm]	d <sub>B</sub> [mm]	Hub		Bore	
				d <sub>N</sub> x l <sub>N</sub> [mm]	d <sub>V</sub> [mm]	d <sub>max</sub> [mm]	
45	315,56	318,35	325	150x15	30H7	286	
46	322,63	325,42	331	150x15	30H7	293	
47	329,71	332,50	338	150x15	30H7	300	
48	336,78	339,57	344	150x15	30H7	307	
49	343,86	346,35	353	150x15	30H7	314	
50	350,93	353,72	363	150x15	30H7	321	
51	358,01	360,80	370	150x15	30H7	328	
52	365,08	367,87	376	150x15	30H7	335	
53	372,15	374,95	382	150x15	30H7	342	
54	379,23	382,02	389	150x15	30H7	349	
55	386,30	389,09	395	150x15	30H7	356	
56	393,38	396,17	401	150x15	30H7	363	
57	400,45	403,24	408	150x15	30H7	370	
58	407,53	410,32	414	150x15	30H7	378	
59	414,60	417,39	427	150x15	30H7	385	
60	421,67	424,47	433	150x15	30H7	392	
61	428,75	431,54	440	150x15	40H7	399	
62	435,82	438,62	446	150x15	40H7	406	
63	442,90	445,69	452	150x15	40H7	413	
64	449,97	452,76	459	150x15	40H7	420	
65	457,05	459,84	468	150x15	40H7	427	
66	464,12	466,91	474	150x15	40H7	434	
67	471,20	473,99	481	150x15	40H7	441	
68	478,27	481,06	490	150x15	40H7	448	
69	485,35	488,14	497	150x15	40H7	455	
70	492,42	495,21	503	150x15	40H7	462	
71	499,49	502,29	510	150x15	40H7	469	
72	506,57	509,36	516	150x15	40H7	477	
73	513,64	516,43	522	160x15	40H7	484	
74	520,72	523,51	529	160x15	40H7	491	
75	527,79	530,58	535	160x15	40H7	498	
76	534,87	537,66	544	160x15	40H7	505	
77	541,94	544,73	554	160x15	40H7	512	
78	549,01	551,81	561	160x15	40H7	519	
79	556,09	558,88	567	160x15	40H7	526	

z	d <sub>K</sub> [mm]	d <sub>0</sub> [mm]	d <sub>B</sub> [mm]	Hub		Bore	
				d <sub>N</sub> x l <sub>N</sub> [mm]	d <sub>V</sub> [mm]	d <sub>max</sub> [mm]	
80	563,16	565,95	573	160x15	40H7	533	
81	570,24	573,03	580	160x15	40H7	540	
82	577,31	580,10	586	160x15	40H7	547	
83	584,39	587,18	594	160x15	40H7	554	
84	591,46	594,25	602	160x15	40H7	561	
85	598,54	601,33	611	160x15	40H7	569	
86	605,61	608,40	618	160x15	40H7	576	
87	612,68	615,48	624	160x15	40H7	583	
88	619,76	622,55	631	160x15	40H7	590	
89	626,83	629,62	637	160x15	40H7	597	
90	633,91	636,70	643	160x15	40H7	604	
91	640,98	643,77	650	160x15	40H7	611	
92	648,06	650,85	658	160x15	40H7	618	
93	655,13	657,92	665	160x15	40H7	625	
94	662,21	665,00	672	160x15	40H7	632	
95	669,27	672,07	681	160x15	40H7	639	
96	676,35	679,15	688	160x15	40H7	646	
97	683,44	686,22	694	160x15	40H7	653	
98	690,50	693,29	701	160x15	40H7	660	
99	697,59	700,37	707	160x15	40H7	668	
100	704,65	707,44	713	160x15	40H7	675	
101	711,74	714,52	722	160x15	40H7	682	
102	718,80	721,59	729	160x15	40H7	689	
103	725,88	728,67	735	160x15	40H7	696	
104	732,95	735,74	743	160x15	40H7	703	
105	740,03	742,82	750	160x15	40H7	710	
106	747,09	749,89	757	160x15	40H7	717	
107	754,18	756,96	764	160x15	40H7	724	
108	761,24	764,04	772	160x15	40H7	731	
109	768,33	771,11	778	160x15	40H7	738	
110	775,39	778,19	785	160x15	40H7	745	
111	782,48	785,26	792	160x15	40H7	752	
112	789,54	792,34	800	160x15	40H7	760	
113	796,62	799,41	806	160x15	40H7	767	
114	803,68	806,49	813	160x15	40H7	774	

# Timing pulleys Special Profiles

## K 1.5

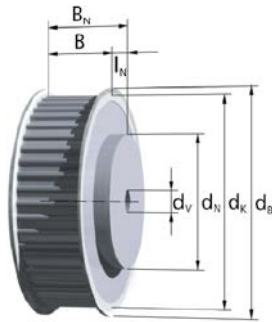

Stock pulleys over  $z = 32$  with flanges

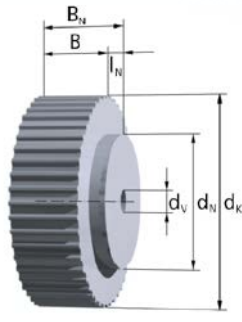

Stock pulleys up to  $z = 24$  without flanges

### Order example:

Pulley Al 14 K 1.5 / 32 - 2 10x6; dv  
 Material \_\_\_\_\_  
 Total width  $B_N$  \_\_\_\_\_  
 Type / pitch \_\_\_\_\_  
 Number of teeth \_\_\_\_\_  
 Number of flanges \_\_\_\_\_  
 Hub dimension  $d_N \times l_N$  \_\_\_\_\_

Note for part code:

$d_v$  = Diameter pre-drilled.

Refer to page 14 for further ordering information.

Belt width	$b$ [mm]	4	6	10
Pulley width	$B$ [mm]	8	10	14
Total width	$B_N$ [mm]	14	16	20

### Material:

AlCu4MgSi, RoHS-conformant

The stock pulleys with standard dimensioning are marked in blue.

In-between widths and larger widths as well as other hub dimensions are available.

- $z$  = Number of teeth
- $d_k$  = Outside diameter
- $d_0$  = Pitch circle diameter
- $d_B$  = Flange diameter
- $d_N$  = Hub diameter

- $l_N$  = Hub length
- $d_v$  = Pre-bore diameter
- $d_{max}$  = max. bore diameter without keyway for flanged timing pulleys; no hub at maximum pre-bore

$z$	$d_k$ [mm]	$d_0$ [mm]	$d_B$ [mm]	Hub $d_N \times l_N$ [mm]	Bore $d_v$ $d_{max}$ [mm] [mm]
20	9,08	9,55	-	-	3H7 3,5
21	9,56	10,03	-	-	3H7 3,5
22	10,03	10,50	-	-	3H7 3,5
23	10,51	10,98	-	-	3H7 4
24	10,99	11,46	-	-	3H7 4
25	11,47	11,94	-	-	3H7 5
26	11,94	12,41	-	-	3H7 5
27	12,42	12,89	-	-	3H7 5
28	12,90	13,37	-	-	3H7 6
29	13,38	13,85	-	-	3H7 6

$z$	$d_k$ [mm]	$d_0$ [mm]	$d_B$ [mm]	Hub $d_N \times l_N$ [mm]	Bore $d_v$ $d_{max}$ [mm] [mm]
30	13,85	14,32	-	-	3H7 6
31	14,33	14,80	-	-	3H7 8
32	14,81	15,28	18	10x6	3H7 8
33	15,29	15,76	19	10x6	4H7 8
34	15,76	16,23	19	10x6	4H7 9
35	16,24	16,71	19	10x6	4H7 9
36	16,72	17,19	20	10x6	4H7 10
37	17,20	17,67	20	10x6	4H7 10
38	17,67	18,14	20	10x6	4H7 10
39	18,15	18,62	22	10x6	4H7 11
40	18,63	19,10	22	12x6	4H7 12
41	19,11	19,58	22	12x6	4H7 12
42	19,58	20,05	22	12x6	4H7 12
43	20,06	20,53	24	12x6	4H7 13
44	20,54	21,01	24	12x6	4H7 13



## K 1.5

z	d <sub>K</sub> [mm]	d <sub>0</sub> [mm]	d <sub>B</sub> [mm]	Hub		Bore	
				d <sub>N</sub> x l <sub>N</sub> [mm]	d <sub>V</sub> [mm]	d <sub>max</sub> [mm]	
45	21,02	21,49	24	12x6	4H7	13	
46	21,49	21,96	24	12x6	4H7	13	
47	21,97	22,44	25	12x6	4H7	14	
48	22,45	22,92	26	14x6	4H7	14	
49	22,93	23,40	26	14x6	4H7	14	
50	23,40	23,87	28	14x6	4H7	14	
51	23,88	24,35	28	14x6	4H7	16	
52	24,36	24,83	28	14x6	4H7	16	
53	24,84	25,31	28	14x6	4H7	16	
54	25,31	25,78	28	14x6	4H7	16	
55	25,79	26,26	30	14x6	4H7	18	
56	26,27	26,74	30	14x6	4H7	18	
57	26,75	27,22	30	14x6	4H7	18	
58	27,22	27,69	32	14x6	4H7	18	
59	27,70	28,17	32	14x6	4H7	18	
60	28,18	28,65	32	14x6	4H7	18	
61	28,66	29,13	32	14x6	4H7	18	
62	29,13	29,60	32	14x6	4H7	18	
63	29,61	30,08	35	14x6	4H7	18	
64	30,09	30,56	35	14x6	4H7	21	
65	30,57	31,04	35	16x6	4H7	21	
66	31,04	31,51	35	16x6	4H7	21	
67	31,52	31,99	35	16x6	4H7	21	
68	32,00	32,47	36	16x6	4H7	21	
69	32,48	32,95	36	16x6	4H7	21	
70	32,95	33,42	36	16x6	5H7	21	
71	33,43	33,90	36	16x6	5H7	21	
72	33,91	34,38	36	16x6	5H7	24	
73	34,38	34,85	40	16x6	5H7	24	
74	34,86	35,33	40	16x6	5H7	24	
75	35,34	35,81	40	20x6	5H7	24	
76	35,82	36,29	42	20x6	5H7	26	
77	36,29	36,76	42	20x6	5H7	26	
78	36,77	37,24	42	20x6	5H7	26	
79	37,25	37,72	42	20x6	5H7	26	

z	d <sub>K</sub> [mm]	d <sub>0</sub> [mm]	d <sub>B</sub> [mm]	Hub		Bore	
				d <sub>N</sub> x l <sub>N</sub> [mm]	d <sub>V</sub> [mm]	d <sub>max</sub> [mm]	
80	37,73	38,20	42	20x6	5H7	26	
81	38,20	38,67	42	20x6	5H7	26	
82	38,68	39,15	42	20x6	5H7	26	
83	39,16	39,63	45	20x6	5H7	28	
84	39,64	40,11	45	20x6	5H7	28	
85	40,11	40,58	45	20x6	5H7	28	
86	40,59	41,06	45	20x6	5H7	28	
87	41,07	41,54	45	20x6	5H7	28	
88	41,55	42,02	47	20x6	5H7	33	
89	42,02	42,49	47	20x6	5H7	33	
90	42,50	42,97	47	24x6	5H7	33	
91	42,98	43,45	47	24x6	5H7	33	
92	43,46	43,93	47	24x6	5H7	33	
93	43,93	44,40	47	24x6	5H7	33	
94	44,41	44,88	50	24x6	5H7	36	
95	44,89	45,36	50	24x6	5H7	36	
96	45,37	45,84	50	24x6	5H7	36	
97	45,84	46,31	50	24x6	5H7	36	
98	46,32	46,79	50	24x6	5H7	36	
99	46,80	47,27	50	24x6	5H7	36	
100	47,28	47,75	53	30x6	6H7	36	
101	47,75	48,22	53	30x6	6H7	36	
102	48,23	48,70	53	30x6	6H7	36	
103	48,71	49,18	53	30x6	6H7	36	
104	49,19	49,66	53	30x6	6H7	41	
105	49,66	50,13	55	30x6	6H7	41	
106	50,14	50,61	55	30x6	6H7	41	
107	50,62	51,09	55	30x6	6H7	41	
108	51,10	51,57	55	30x6	6H7	41	
109	51,57	52,04	56	30x6	6H7	41	
110	52,05	52,52	56	30x6	6H7	42	
111	52,53	53,00	56	30x6	6H7	42	
112	53,01	53,48	58	30x6	6H7	44	
113	53,48	53,95	58	30x6	6H7	44	
114	53,96	54,43	58	30x6	6H7	44	

# Timing pulley bars

## AT-Profiles (AT 3, AT 5)

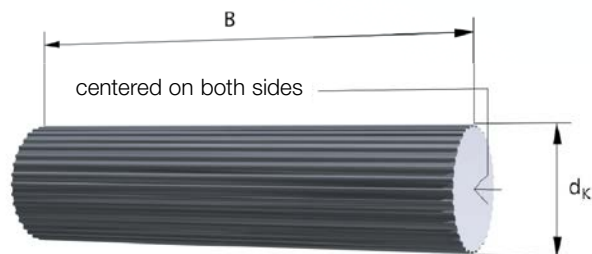

Tooth gaps:

- Normal gap (Standard, no order code necessary),
- SE gap (order code: -SE),
- Zero gap (order code: -0)

- z = Number of teeth
- B = Width [mm]
- $d_k$  = Outside diameter
- $d_o$  = Pitch circle diameter
- $d_b$  = Flange diameter
- $d_i$  = Inner flange diameter
- s = Flange thickness

### Pitch and widths [mm]

AT 3						
z	B	$d_k$	$d_o$	$d_b$	$d_i$	s
15	180	13,91	14,32	19	11	1
16	180	14,87	15,28	20	12	1
17	180	15,82	16,23	21	13	1
18	180	16,78	17,19	23	14	1
19	180	17,73	18,14	23	14	1
20	180	18,69	19,10	24	14	1
21	180	19,64	20,05	25	15	1
22	180	20,60	21,01	27	17	1
23	180	21,55	21,96	27	17	1
24	180	22,51	22,92	28	18	1
25	180	23,46	23,87	30	20	1
26	180	24,42	24,83	30	20	1
27	180	25,37	25,78	30	20	1
28	180	26,33	26,74	31	21	1
29	180	27,28	27,69	32	22	1
30	180	28,24	28,65	33	23	1
31	180	29,19	29,60	34	24	1
32	180	30,15	30,56	36	25	1
33	180	31,10	31,51	36	25	1
34	180	32,06	32,47	37	27	1

### Order example Timing pulley bars:

SW 180 AT 5 - SE / 48

Material \_\_\_\_\_

Width \_\_\_\_\_

Type / pitch \_\_\_\_\_

Toothform variant \_\_\_\_\_

Number of teeth \_\_\_\_\_

**Material:** AlCu4MgSi, RoHS-conformant

### Order example flanges:

BS 60 x 48 x 1

Flange \_\_\_\_\_

Outside diameter  $d_b$  \_\_\_\_\_

Inside diameter  $d_i$  \_\_\_\_\_

Thickness s \_\_\_\_\_

AT 5						
z	B	$d_k$	$d_o$	$d_b$	$d_i$	s
15	150	22,65	23,87	28	18	1
16	150	24,24	25,46	30	20	1
17	150	25,84	27,06	31	21	1
18	150	27,43	28,65	34	24	1
19	150	29,02	30,24	34	24	1
20	180	30,61	31,83	36	26	1
21	180	32,20	33,42	37	27	1
22	180	33,79	35,01	39	29	1
23	180	35,39	36,61	40	29	1
24	180	36,98	38,20	43	31	1
25	180	38,57	39,79	43	31	1
26	180	40,16	41,38	45	33	1
27	180	41,75	42,97	47	35	1
28	180	43,34	44,56	48	34	1
29	180	44,93	46,15	50	36	1
30	180	46,53	47,75	51	39	1
31	180	48,12	49,35	53	41	1
32	180	49,71	50,93	55	43	1
33	180	51,30	52,52	56	44	1
34	180	52,89	54,11	58	46	1

## AT-Profiles (AT 3, AT 5)

AT 3						
z	B	d <sub>k</sub>	d <sub>0</sub>	d <sub>B</sub>	d <sub>i</sub>	s
35	180	33,01	33,42	39	29	1
36	180	33,97	34,38	40	29	1
37	180	34,92	35,33	40	29	1
38	180	35,88	36,29	42	30	1
39	180	36,83	37,24	42	30	1
<hr/>						
40	180	37,79	38,20	43	31	1
41	180	38,74	39,15	45	33	1
42	180	39,70	40,11	45	33	1
43	180	40,65	41,06	47	34	1
44	180	41,61	42,02	47	34	1
<hr/>						
45	180	42,56	42,97	48	34	1
46	180	43,52	43,93	50	36	1
47	180	44,47	44,88	50	36	1
48	180	45,43	45,84	51	39	1
49	180	46,38	46,79	51	39	1
<hr/>						
50	180	47,34	47,75	53	41	1
51	180	48,29	48,70	53	41	1
52	180	49,25	49,66	55	43	1
53	180	50,20	50,61	55	43	1
54	180	51,16	51,57	56	44	1
<hr/>						
55	180	52,11	52,52	58	46	1
56	180	53,07	53,48	58	46	1
57	180	54,02	54,43	60	48	1
58	180	54,98	55,39	60	48	1
59	180	55,93	56,34	61	49	1
<hr/>						
60	180	56,89	57,30	62	50	1
61	180	57,84	58,25	64	52	1
62	180	58,80	59,21	64	52	1
63	180	59,75	60,16	66	52	1
64	180	60,71	61,12	66	52	1
<hr/>						
65	180	61,66	62,07	68	54	1
66	180	62,62	63,03	68	54	1
67	180	63,57	63,98	70	56	1
68	180	64,53	64,94	70	56	1
69	180	65,48	65,89	72	58	1
<hr/>						
70	180	66,44	66,85	72	58	1
71	180	67,39	67,80	74	60	1
72	180	68,34	68,75	74	60	1

AT 5						
z	B	d <sub>k</sub>	d <sub>0</sub>	d <sub>B</sub>	d <sub>i</sub>	s
35	180	54,48	55,70	60	48	1
36	180	56,08	57,30	61	49	1
37	180	57,67	58,89	62	50	1
38	180	59,26	60,48	64	52	1
39	180	60,85	62,07	66	52	1
<hr/>						
40	180	62,44	63,66	67	55	1
41	180	64,03	65,25	70	56	1
42	180	65,63	66,85	70	56	1
43	180	67,22	68,44	72	58	1
44	180	68,81	70,03	74	60	1
<hr/>						
45	180	70,40	71,62	75	61	1
46	180	71,99	73,21	78	64	1
47	180	73,58	74,80	78	64	1
48	180	75,15	76,39	80	66	1
49	180	76,77	77,99	82	68	1
<hr/>						
50	180	78,36	79,58	84	70	1
51	180	79,95	81,17	86	72	1
52	180	81,54	82,76	86	72	1
53	180	83,13	84,35	88	74	1
54	180	84,72	85,94	90	76	1
<hr/>						
55	180	86,32	87,54	91	77	1
56	180	87,91	89,13	93	79	1
57	180	89,50	90,72	94	80	1
58	180	91,09	92,31	96	82	1
59	180	92,68	93,90	99	85	1
<hr/>						
60	180	94,27	95,49	99	85	1
61	180	95,86	97,08	100	86	1
62	180	97,46	98,68	102	88	1
63	180	99,05	100,27	104	90	1
64	180	100,64	101,86	105	91	1,5
<hr/>						
65	180	102,23	103,45	107	93	1,5
66	180	103,82	105,04	109	95	1,5
67	180	105,41	106,63	112	98	1,5
68	180	107,01	108,23	112	98	1,5
69	180	108,60	109,82	115	101	1,5
<hr/>						
70	180	110,19	111,41	115	101	1,5
71	180	111,78	113,00	117	103	1,5
72	180	113,37	114,59	118	104	1,5

# Timing pulley bars

## AT-Profiles (AT 10)

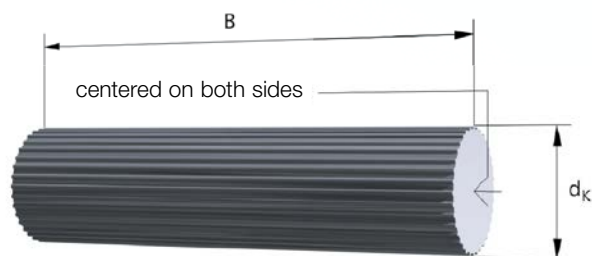

Tooth gaps:

- Normal gap (Standard, no order code necessary),
- SE gap (order code: -SE),
- Zero gap (order code: -0)

- z = Number of teeth
- B = Width [mm]
- $d_k$  = Outside diameter
- $d_o$  = Pitch circle diameter
- $d_b$  = Flange diameter
- $d_i$  = Inner flange diameter
- s = Flange thickness

### Pitch and widths [mm]

AT 10						
z	B	$d_k$	$d_o$	$d_b$	$d_i$	s
15	180	45,93	47,75	51	39	1
16	180	49,11	50,93	55	43	1
17	180	52,29	54,11	58	46	1
18	180	55,48	57,30	61	49	1
19	180	58,66	60,48	64	52	1
<hr/>						
20	180	61,84	63,66	67	55	1
21	180	65,03	66,85	70	56	1
22	180	68,21	70,03	74	60	1
23	180	71,39	73,21	76	62	1
24	180	74,57	76,39	80	66	1
<hr/>						
25	180	77,76	79,58	82	69	1
26	180	80,94	82,76	86	72	1
27	180	84,12	85,94	90	76	1
28	180	87,31	89,13	93	79	1
29	180	90,49	92,31	96	82	1
<hr/>						
30	180	93,67	95,49	99	85	1
31	180	96,86	98,68	102	88	1
32	180	100,04	101,86	105	91	1
33	180	103,22	105,04	110	96	1,5
34	180	106,41	108,23	113	99	1,5

### Order example Timing pulley bars:

SW 180 AT 10 - SE / 48

Material \_\_\_\_\_

Width \_\_\_\_\_

Type / pitch \_\_\_\_\_

Toothform variant \_\_\_\_\_

Number of teeth \_\_\_\_\_

**Material:** AlCu4MgSi, RoHS-conformant

### Order example flanges:

BS 156 x 140 x 1,5

Flange \_\_\_\_\_

Outside diameter  $d_b$  \_\_\_\_\_

Inside diameter  $d_i$  \_\_\_\_\_

Thickness s \_\_\_\_\_



## AT-Profiles (AT 10)

Pitch and widths [mm]

AT 10						
z	B	d <sub>k</sub>	d <sub>0</sub>	d <sub>B</sub>	d <sub>i</sub>	s
35	180	109,59	111,41	115	101	1,5
36	180	112,77	114,59	118	104	1,5
37	180	115,95	117,77	121	107	1,5
38	180	119,14	120,96	126	112	1,5
39	180	122,32	124,14	129	115	1,5
40	180	125,50	127,32	131	115	1,5
41	180	128,69	130,51	134	120	1,5
42	180	131,87	133,69	137	123	1,5
43	180	135,05	136,87	140	126	1,5
44	180	138,24	140,06	145	131	1,5
45	180	141,42	143,24	148	134	1,5
46	180	144,60	146,42	150	136	1,5
47	180	147,79	149,61	153	139	1,5
48	180	150,97	152,79	156	140	1,5
49	180	154,15	155,97	161	147	1,5
50	180	157,33	159,15	164	150	1,5
51	180	160,52	162,34	166	152	1,5
52	180	163,70	165,52	169	155	1,5
53	180	166,88	168,70	172	158	1,5
54	180	170,07	171,89	176	163	1,5
55	180	173,25	175,07	179	165	1,5
56	180	176,43	178,25	182	168	1,5
57	180	179,62	181,44	185	171	1,5
58	180	182,80	184,62	188	174	1,5
59	180	185,98	187,80	191	177	1,5
60	180	189,17	190,99	195	181	1,5
61	180	192,35	194,17	198	184	1,5
62	180	195,53	197,35	201	187	1,5
63	180	198,72	200,54	204	190	1,5
64	180	201,90	203,72	207	193	1,5
65	180	205,08	206,90	210	196	1,5
66	180	208,26	210,08	214	200	1,5
67	180	211,45	213,27	217	203	1,5
68	180	214,63	216,45	220	206	1,5
69	180	217,81	219,63	223	209	1,5
70	180	221,00	222,82	226	212	1,5
71	180	224,18	226,00	230	216	1,5
72	180	227,36	229,18	233	219	1,5

# Timing pulley bars

## T-Profiles (T 2.5, T 5, T 10)

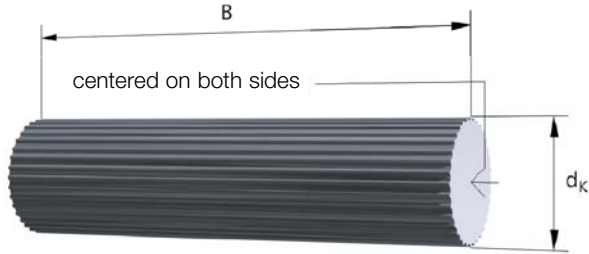

### Order example Timing pulley bars:

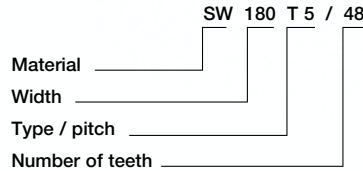

### Tooth gaps:

- Normal gap (Standard, no order code necessary),
- SE gap (order code: -SE),
- Zero gap (order code: -0)

**Material:** AlCu4MgSi, RoHS-conformant

- z = Number of teeth
- B = Width [mm]
- d<sub>k</sub> = Outside diameter
- d<sub>o</sub> = Pitch circle diameter
- d<sub>B</sub> = Flange diameter
- d<sub>i</sub> = Inner flange diameter
- s = Flange thickness

### Order example flanges:

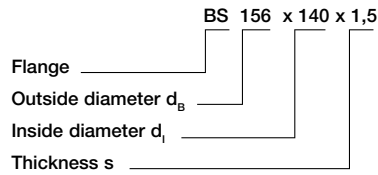

### Pitch and widths [mm]

z	T 2.5						T 5						T 10					
	B	d <sub>k</sub>	d <sub>o</sub>	d <sub>B</sub>	d <sub>i</sub>	s	B	d <sub>k</sub>	d <sub>o</sub>	d <sub>B</sub>	d <sub>i</sub>	s	B	d <sub>k</sub>	d <sub>o</sub>	d <sub>B</sub>	d <sub>i</sub>	s
15	120	11,40	11,94	15	9	1	150	23,05	23,87	28	18	1	180	45,90	47,75	51	39	1
16	150	12,20	12,73	16	10	1	150	24,60	25,46	30	20	1	180	49,10	50,93	55	43	1
17	150	13,00	13,53	16	10	1	150	26,20	27,06	31	21	1	180	52,25	54,11	58	46	1
18	180	13,80	14,32	17	11	1	180	27,80	28,65	34	24	1	180	55,44	57,30	61	49	1
19	180	14,60	15,12	18	12	1	180	29,40	30,24	34	24	1	180	58,64	60,48	64	52	1
20	180	15,40	15,92	19	11	1	180	31,00	31,83	36	26	1	180	61,80	63,66	67	55	1
21	180	16,20	16,71	20	12	1	180	32,60	33,42	37	27	1	180	65,00	66,85	70	56	1
22	180	17,00	17,51	20	12	1	180	34,15	35,01	39	29	1	180	68,20	70,03	74	60	1
23	180	17,80	18,30	21	13	1	180	35,75	36,61	40	29	1	180	71,35	73,21	76	62	1
24	180	18,55	19,10	22	14	1	180	37,35	38,20	43	31	1	180	74,55	76,39	80	66	1
25	180	19,35	19,89	23	14	1	180	38,95	39,75	43	31	1	180	77,75	79,58	83	69	1
26	180	20,15	20,69	23	14	1	180	40,55	41,83	45	33	1	180	80,90	82,76	86	72	1
27	180	20,95	21,49	24	14	1	180	42,15	42,97	47	35	1	180	84,10	85,94	90	76	1
28	180	21,75	22,28	25	15	1	180	43,75	44,56	48	34	1	180	87,25	89,13	93	79	1
29	180	22,55	23,08	26	16	1	180	45,30	46,15	50	36	1	180	90,45	92,31	96	82	1
30	180	23,35	23,87	27	17	1	180	46,90	47,75	51	39	1	180	93,65	95,49	99	85	1
31	180	24,15	24,67	27	17	1	180	48,50	49,34	53	41	1	180	96,80	98,68	102	88	1
32	180	24,95	25,46	28	18	1	180	50,10	50,93	55	43	1	180	100,00	101,86	105	91	1
33	180	25,75	26,26	28	18	1	180	51,70	52,52	56	44	1	180	103,20	105,04	110	96	1,5
34	180	26,55	27,06	30	20	1	180	53,30	54,11	58	46	1	180	106,35	108,23	113	99	1,5

## T-Profiles (T 2.5, T 5, T 10)

Pitch and widths [mm]

z	T 2.5						T 5						T 10					
	B	d <sub>k</sub>	d <sub>0</sub>	d <sub>B</sub>	d <sub>I</sub>	s	B	d <sub>k</sub>	d <sub>0</sub>	d <sub>B</sub>	d <sub>I</sub>	s	B	d <sub>k</sub>	d <sub>0</sub>	d <sub>B</sub>	d <sub>I</sub>	s
35	180	27,35	27,85	31	21	1	186	54,85	55,70	60	48	1	180	109,55	111,41	115	101	1,5
36	180	28,15	28,65	31	21	1	180	56,45	57,30	61	49	1	180	112,75	114,59	118	104	1,5
37	180	28,90	29,44	32	22	1	180	58,05	58,89	62	50	1	180	115,90	117,77	121	107	1,5
38	180	29,70	30,24	33	23	1	180	59,65	60,48	64	52	1	180	119,10	120,96	126	112	1,5
39	180	30,50	31,04	34	24	1	180	61,25	62,07	66	52	1	180	122,30	124,14	129	115	1,5
40	180	31,30	31,83	35	25	1	180	62,85	63,66	67	55	1	180	125,45	127,32	131	115	1,5
41	180	32,10	32,63	35	25	1	180	64,40	65,25	70	56	1	180	128,65	130,51	134	120	1,5
42	180	32,90	33,42	36	26	1	180	66,00	66,85	70	56	1	180	131,85	133,69	137	123	1,5
43	180	33,70	34,22	37	27	1	180	67,60	68,44	72	58	1	180	135,00	136,87	140	126	1,5
44	180	34,50	35,01	39	29	1	180	69,20	70,03	74	60	1	180	138,20	140,06	145	131	1,5
45	180	35,30	35,81	39	29	1	180	70,80	71,62	75	61	1	180	141,40	143,24	148	134	1,5
46	180	36,10	36,61	39	29	1	180	72,40	73,21	78	64	1	180	144,50	146,42	150	136	1,5
47	180	36,90	37,40	40	29	1	180	73,95	74,80	78	64	1	180	147,75	149,61	153	139	1,5
48	180	37,70	38,20	42	30	1	180	75,55	76,39	80	66	1	180	150,95	152,79	156	140	1,5
49	180	38,45	38,99	42	30	1	180	77,15	77,99	82	68	1	180	154,10	155,97	161	147	1,5
50	180	39,25	39,79	43	31	1	180	78,75	79,58	84	70	1	180	157,30	159,15	164	150	1,5
51	180	40,05	40,58	43	31	1	180	80,35	81,17	86	72	1	180	160,50	162,34	166	152	1,5
52	180	40,85	41,38	45	33	1	180	81,95	82,76	86	72	1	180	163,65	165,52	169	155	1,5
53	180	41,65	42,18	45	33	1	180	83,55	84,35	88	74	1	180	166,85	168,70	172	158	1,5
54	180	42,45	42,97	47	34	1	180	85,10	85,94	90	76	1	180	170,05	171,89	177	163	1,5
55	180	43,25	43,77	47	34	1	180	86,70	87,54	91	77	1	180	173,20	175,07	179	165	1,5
56	180	44,05	44,56	47	34	1	180	88,30	89,13	93	79	1	180	176,40	178,25	182	168	1,5
57	180	44,85	45,36	48	34	1	180	89,90	90,72	94	80	1	180	179,60	181,44	185	171	1,5
58	180	45,65	46,15	50	36	1	180	91,50	92,31	96	82	1	180	182,75	184,62	188	174	1,5
59	180	46,45	46,95	50	36	1	180	93,10	93,90	97	83	1	180	185,95	187,80	191	177	1,5
60	180	47,25	47,75	52	40	1	180	94,65	95,49	99	85	1	180	189,15	190,99	195	181	1,5
61	180	48,05	48,54	52	40	1	180	96,25	97,08	100	88	1	180	192,30	194,17	198	184	1,5
62	180	48,80	49,34	53	41	1	180	97,85	98,68	102	88	1	180	195,50	197,35	201	187	1,5
63	180	49,60	50,13	53	41	1	180	99,45	100,27	104	90	1	180	198,70	200,54	204	190	1,5
64	180	50,40	50,93	55	43	1	180	101,05	101,86	105	91	1,5	180	201,85	203,72	207	193	1,5
65	180	51,20	51,73	55	43	1	180	102,65	103,45	107	93	1,5	180	205,05	206,90	210	196	1,5
66	180	52,00	52,52	55	43	1	180	104,20	105,04	109	95	1,5	180	208,25	210,08	214	200	1,5
67	180	52,80	53,32	55	43	1	180	105,80	106,63	112	98	1,5	180	211,40	213,27	217	203	1,5
68	180	53,60	54,11	57	46	1	180	107,40	108,23	112	98	1,5	180	214,60	216,45	220	206	1,5
69	180	54,40	54,91	58	46	1	180	109,00	109,82	115	101	1,5	180	217,80	219,63	223	209	1,5
70	180	55,20	55,70	60	48	1	180	110,60	111,41	115	101	1,5	180	220,95	222,82	226	212	1,5
71	180	56,00	56,50	60	48	1	180	112,20	113,00	117	103	1,5	180	224,15	226,00	230	216	1,5
72	180	56,80	57,30	60	48	1	180	113,75	114,59	118	104	1,5	180	227,35	229,18	233	219	1,5

# Timing pulley bars

## Imperial-Profiles (XL, L, H) (T1/5", T3/8", T1/2")

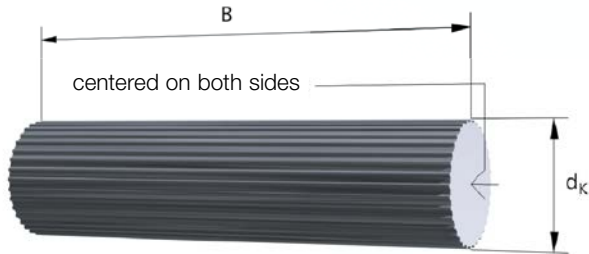

### Order example Timing pulley bars:

Material  SW 180 XL / 48  
 Width   
 Type / pitch   
 Number of teeth

Material: AlCu4MgSi, RoHS-conformant

- z = Number of teeth
- B = Width [mm]
- d<sub>k</sub> = Outside diameter
- d<sub>0</sub> = Pitch circle diameter
- d<sub>B</sub> = Flange diameter
- d<sub>i</sub> = Inner flange diameter
- s = Flange thickness

### Order example flanges:

Flange  BS 117 x 103 x 1,5  
 Outside diameter d<sub>B</sub>   
 Inside diameter d<sub>i</sub>   
 Thickness s

### Pitch and widths [mm]

z	XL						L						H					
	B	d <sub>k</sub>	d <sub>0</sub>	d <sub>B</sub>	d <sub>i</sub>	s	B	d <sub>k</sub>	d <sub>0</sub>	d <sub>B</sub>	d <sub>i</sub>	s	B	d <sub>k</sub>	d <sub>0</sub>	d <sub>B</sub>	d <sub>i</sub>	s
15	-	-	-	-	-	-	180	44,72	45,48	51	40	1	180	59,27	60,64	67	53	1
16	-	-	-	-	-	-	180	47,75	48,51	55	42	1	180	63,31	64,68	70	56	1
17	180	26,98	27,49	32	22	1	180	50,78	51,54	58	44	1	180	67,35	68,72	74	60	1
18	180	28,60	29,11	35	25	1	180	53,81	54,57	61	47	1	180	71,39	72,77	76	62	1
19	180	30,22	30,72	36	26	1	180	56,84	57,61	64	50	1	180	75,44	76,81	82	68	1
20	180	31,83	32,34	37	27	1	180	59,88	60,64	67	53	1	180	79,48	80,85	86	72	1
21	180	33,45	33,96	39	29	1	180	62,91	63,67	70	56	1	180	83,52	84,89	90	76	1
22	180	35,07	35,57	40	30	1	180	65,94	66,70	72	58	1	180	87,56	88,94	93	79	1
23	180	36,68	37,19	42	30	1	180	68,97	69,73	74	60	1	180	91,61	92,98	96	82	1
24	180	38,30	38,81	43	31	1	180	72,00	72,77	78	64	1	180	95,65	97,02	102	88	1
25	180	39,92	40,43	45	33	1	180	75,04	75,80	82	68	1	180	99,69	101,06	105	91	1,5
26	180	41,53	42,04	47	35	1	180	78,07	78,83	84	68	1	180	103,73	105,11	110	96	1,5
27	180	43,15	43,66	48	36	1	180	81,10	81,86	86	72	1	180	107,78	109,15	113	99	1,5
28	180	44,77	45,28	50	38	1	180	84,13	84,89	90	76	1	180	111,82	113,19	117	103	1,5
29	180	46,38	46,89	52	40	1	180	87,16	87,92	93	79	1	180	115,86	117,23	121	107	1,5



## Imperial-Profiles (XL, L, H) (T1/5", T3/8", T1/2")

z	XL						L						H					
	B	d <sub>k</sub>	d <sub>0</sub>	d <sub>B</sub>	d <sub>I</sub>	s	B	d <sub>k</sub>	d <sub>0</sub>	d <sub>B</sub>	d <sub>I</sub>	s	B	d <sub>k</sub>	d <sub>0</sub>	d <sub>B</sub>	d <sub>I</sub>	s
30	180	48,00	48,51	53	41	1	180	90,20	90,96	97	83	1	180	119,90	121,28	126	112	1,5
31	180	49,62	50,13	55	43	1	180	93,23	93,99	99	85	1	180	123,95	125,32	129	115	1,5
32	180	51,24	51,74	56	44	1	180	96,26	97,02	101	87	1	180	127,99	129,36	134	120	1,5
33	180	52,85	53,36	58	46	1	180	99,29	100,05	106	92	1,5	180	132,03	133,40	137	123	1,5
34	180	54,17	54,98	60	48	1	180	102,32	103,08	108	94	1,5	180	136,08	137,45	142	128	1,5
35	180	56,09	56,60	62	50	1	180	105,36	106,12	110	96	1,5	180	140,12	141,49	145	131	1,5
36	180	57,70	58,21	62	50	1	180	108,39	109,15	115	101	1,5	180	144,16	145,53	150	136	1,5
37	180	59,39	59,83	64	52	1	180	111,42	112,18	118	104	1,5	180	148,20	149,57	153	139	1,5
38	180	60,94	61,45	66	52	1	180	114,45	115,21	121	107	1,5	180	152,25	153,62	158	144	1,5
39	180	62,55	63,06	68	54	1	180	117,48	118,24	123	109	1,5	180	156,29	157,66	161	147	1,5
40	180	64,17	64,68	72	58	1	180	120,51	121,28	126	112	1,5	180	160,33	161,70	166	152	1,5
41	180	65,97	66,30	72	58	1	180	123,55	124,31	129	115	1,5	180	164,37	165,74	171	157	1,5
42	180	67,40	67,91	72	58	1	180	126,58	127,34	131	117	1,5	180	168,42	169,79	174	160	1,5
43	180	69,02	69,53	74	60	1	180	129,61	130,37	137	119	1,5	180	172,46	173,83	179	165	1,5
44	180	70,64	71,15	75	61	1	180	132,64	133,40	137	123	1,5	180	176,50	177,87	182	168	1,5
45	180	72,26	72,77	78	64	1	180	135,68	136,44	140	126	1,5	180	180,54	181,91	185	171	1,5
46	180	73,87	74,38	80	66	1	180	138,71	139,47	145	131	1,5	180	184,59	185,96	191	177	1,5
47	180	75,49	76,00	80	66	1	180	141,74	142,50	148	134	1,5	180	188,63	190,00	195	181	1,5
48	180	77,11	77,62	82	68	1	180	144,77	145,53	153	139	1,5	180	192,67	194,04	198	184	1,5
49	180	78,72	79,23	84	70	1	180	147,80	148,56	153	139	1,5	180	196,71	198,08	201	187	1,5
50	180	80,34	80,85	86	72	1	180	150,83	151,59	156	142	1,5	180	200,76	202,13	207	193	1,5
51	180	81,96	82,47	88	74	1	180	153,87	154,63	161	147	1,5	180	204,80	206,17	210	196	1,5
52	180	83,57	84,08	90	76	1	180	156,90	157,66	164	150	1,5	180	208,84	210,21	214	200	1,5
53	180	85,19	85,70	90	76	1	180	159,93	160,69	166	152	1,5	180	212,88	214,25	217	203	1,5
54	180	86,81	87,32	91	77	1	180	162,96	163,72	169	155	1,5	180	216,93	218,30	223	209	1,5
55	180	88,43	88,94	93	79	1	180	165,99	166,75	171	157	1,5	180	220,97	222,34	226	212	1,5
56	180	90,04	90,55	96	82	1	180	169,03	169,79	174	160	1,5	180	225,01	226,38	230	216	1,5
57	180	91,66	92,17	99	85	1	180	172,06	172,82	179	165	1,5	180	229,05	230,42	236	222	1,5
58	180	93,28	93,79	99	85	1	180	175,09	175,85	182	168	1,5	180	233,10	234,47	239	225	1,5
59	180	94,89	95,40	100	86	1	180	178,12	178,88	185	171	1,5	180	237,14	238,51	242	228	1,5
60	180	96,51	97,02	102	88	1	180	181,15	181,91	188	174	1,5	180	241,18	242,55	245	231	1,5
61	180	98,13	98,64	104	90	1	180	184,19	184,95	192	175	1,5	180	245,22	246,59	252	238	1,5
62	180	99,74	100,25	106	92	1	180	187,22	187,98	192	175	1,5	180	249,27	250,64	255	241	1,5
63	180	101,36	101,87	106	92	1	180	190,25	191,01	195	181	1,5	180	253,31	254,68	258	244	1,5
64	180	102,98	103,49	109	95	1,5	180	193,28	194,04	198	184	1,5	180	257,35	258,72	261	247	1,5
65	180	104,60	105,11	109	95	1,5	180	196,31	197,07	205	188	1,5	180	261,39	262,76	268	254	1,5
66	180	106,21	106,72	112	98	1,5	180	199,35	200,11	205	188	1,5	180	265,44	266,81	271	257	1,5
67	180	107,83	108,34	115	101	1,5	180	202,38	203,14	210	196	1,5	180	269,48	270,85	274	260	1,5
68	180	109,45	109,96	115	101	1,5	180	205,41	206,17	212	196	1,5	180	273,52	274,89	280	266	1,5
69	180	111,06	111,57	117	103	1,5	180	208,44	209,20	216	200	1,5	180	277,56	278,93	284	270	1,5

# Timing pulley bars

## HTD-Profiles (5M, 8M)

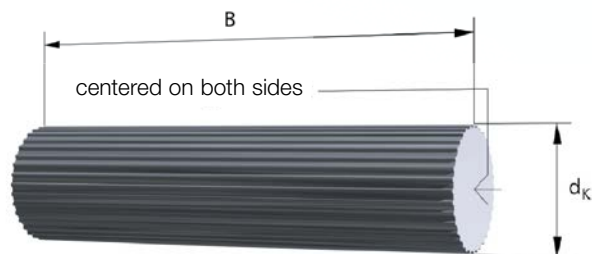

### Order example Timing pulley bars:

Material \_\_\_\_\_ SW 180 5M / 48  
 Width \_\_\_\_\_  
 Type / pitch \_\_\_\_\_  
 Number of teeth \_\_\_\_\_

**Material:** AlCu4MgSi, RoHS-conformant

- z = Number of teeth
- B = Width [mm]
- d<sub>k</sub> = Outside diameter
- d<sub>0</sub> = Pitch circle diameter
- d<sub>B</sub> = Flange diameter
- d<sub>I</sub> = Inner flange diameter
- s = Flange thickness

### Order example flanges:

Flange \_\_\_\_\_ BS 158 x 142 x 1,5  
 Outside diameter d<sub>B</sub> \_\_\_\_\_  
 Inside diameter d<sub>I</sub> \_\_\_\_\_  
 Thickness s \_\_\_\_\_

### Pitch and widths [mm]

5M						
z	B	d <sub>k</sub>	d <sub>0</sub>	d <sub>B</sub>	d <sub>I</sub>	s
15	140	22,73	23,87	28	18	1
16	140	24,32	25,46	28	18	1
17	140	25,92	27,06	32	22	1
18	140	27,51	28,65	32	22	1
19	140	29,10	30,24	36	24	1
<hr/>						
20	160	30,69	31,83	36	24	1
21	160	32,28	33,42	38	28	1
22	160	33,87	35,01	38	28	1
23	160	35,47	36,61	42	30	1
24	160	37,06	38,20	42	30	1
<hr/>						
25	160	38,65	39,79	44	31	1
26	180	40,24	41,38	44	31	1
27	180	41,83	42,97	48	36	1
28	180	43,42	54,46	48	36	1
29	180	45,01	46,15	52	40	1

8M						
z	B	d <sub>k</sub>	d <sub>0</sub>	d <sub>B</sub>	d <sub>I</sub>	s
<hr/>						
22	180	54,65	56,02	60	48	1
23	180	57,20	58,57	63	48	1
24	180	59,75	61,12	66	51	1
<hr/>						
25	180	62,29	63,66	66	51	1
26	180	64,84	66,21	71	57	1
27	180	67,38	68,75	74	60	1
28	180	70,08	71,30	75	61	1
29	180	72,48	73,85	78	64	1

## HTD-Profiles (5M, 8M)

Pitch and widths [mm]

5M						
z	B	d <sub>k</sub>	d <sub>0</sub>	d <sub>B</sub>	d <sub>I</sub>	s
30	180	46,60	47,75	52	40	1
31	180	48,20	49,34	55	41	1
32	180	49,79	50,93	55	41	1
33	180	51,38	52,52	56	44	1
34	180	52,97	54,11	60	44	1
35	180	54,56	55,70	60	48	1
36	180	56,16	57,30	60	48	1
37	180	57,75	58,89	64	52	1
38	180	59,34	60,48	66	52	1
39	180	60,93	62,07	66	52	1
40	180	62,52	63,66	70	56	1
41	180	64,11	65,25	70	56	1
42	180	65,70	66,85	72	58	1
43	180	67,30	68,44	72	58	1
44	180	68,89	70,03	74	60	1
45	180	70,48	71,62	74	60	1
46	180	72,07	73,21	78	64	1
47	180	73,66	74,80	80	66	1
48	180	75,25	76,39	80	66	1
49	180	76,85	77,99	82	68	1
50	180	78,44	79,58	84	70	1
51	180	80,03	81,17	86	72	1
52	180	81,62	82,76	88	74	1
53	180	83,21	84,35	88	74	1
54	180	84,80	85,94	90	76	1
55	180	86,40	87,54	91	77	1
56	180	87,99	89,13	93	79	1
57	180	89,58	90,72	96	82	1
58	180	91,17	92,31	99	85	1
59	180	92,76	93,90	99	85	1
60	180	94,35	95,49	100	86	1
61	180	95,94	97,08	100	86	1
62	180	97,54	98,68	102	88	1
63	180	99,13	100,27	104	90	1
64	180	100,72	101,86	107	93	1,5
65	180	102,31	103,45	109	95	1,5
66	180	103,90	105,04	109	95	1,5
67	180	105,49	106,63	112	98	1,5
68	180	107,09	108,23	112	98	1,5
69	180	108,68	109,82	115	101	1,5

8M						
z	B	d <sub>k</sub>	d <sub>0</sub>	d <sub>B</sub>	d <sub>I</sub>	s
30	180	75,13	76,39	82	66	1
31	180	77,57	78,94	84	70	1
32	180	80,16	81,49	86	72	1
33	180	82,66	84,03	88	74	1
34	180	85,22	86,58	91	77	1
35	180	87,76	89,13	93	79	1
36	180	90,30	91,67	99	83	1
37	180	92,85	94,22	99	83	1
38	180	95,39	96,77	102	88	1
39	180	97,94	99,31	102	88	1
40	180	100,49	101,86	105	91	1,5
41	180	103,04	104,41	107	93	1,5
42	180	105,58	106,95	109	95	1,5
43	180	108,13	109,50	115	101	1,5
44	180	110,67	112,05	117	103	1,5
45	180	113,22	114,59	118	104	1,5
46	180	115,77	117,14	123	106	1,5
47	180	118,31	119,68	125	111	1,5
48	180	120,86	122,23	127	111	1,5
49	180	123,41	124,78	131	115	1,5
50	180	125,95	127,32	131	115	1,5
51	180	128,50	129,87	135	119	1,5
52	180	131,05	132,42	135	119	1,5
53	180	133,59	134,96	140	126	1,5
54	180	136,14	137,51	142	128	1,5
55	180	138,69	140,06	144	130	1,5
56	180	141,23	142,60	147	133	1,5
57	180	143,78	145,15	150	136	1,5
58	180	146,33	147,70	153	139	1,5
59	180	148,87	150,24	156	142	1,5
60	180	151,42	152,79	158	144	1,5
61	180	153,96	155,34	158	142	1,5
62	180	156,51	157,88	163	149	1,5
63	180	159,06	160,43	166	152	1,5
64	180	161,60	162,97	166	152	1,5
65	180	164,15	165,52	171	157	1,5
66	180	166,70	168,07	172	158	1,5
67	180	169,24	170,61	174	160	1,5
68	180	171,79	173,16	176	162	1,5
69	180	174,34	175,71	180	166	1,5

# Timing pulley bars with hubs

## AT-Profiles (AT 5, AT 10)

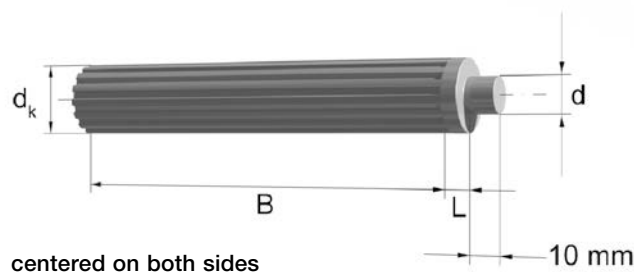

### Order example Timing pulley bars with hubs

Material \_\_\_\_\_ SW 160 AT 5 - 0 / 24

Width \_\_\_\_\_

Type / pitch \_\_\_\_\_

Toothform variant \_\_\_\_\_

Number of teeth \_\_\_\_\_

**Material:** AlCu4MgSi, RoHS-conformant

#### Tooth gaps:

- Normal gap (Standard, no order code necessary),
- SE gap (order code: -SE),
- Zero gap (order code: -0)

- z = Number of teeth
- B = Width [mm]
- d<sub>k</sub> = Outside diameter
- d<sub>0</sub> = Pitch circle diameter
- L = non-toothed length of shaft
- d = hub diameter

#### Pitch and widths [mm]

AT 5					
z	B	d <sub>k</sub>	d <sub>0</sub>	L	d
15	132	22,65	23,87	0	10
16	140	24,24	25,46	0	10
17	140	28,84	27,06	0	10
18	140	27,43	28,65	0	10
19	140	29,02	30,24	0	10
<hr/>					
20	160	30,69	31,83	0	12
21	160	32,28	33,42	0	12
22	160	33,87	35,01	0	12
23	160	35,47	36,61	0	12
24	160	37,06	38,20	0	12
<hr/>					
25	160	38,65	39,79	0	12
26	160	40,24	41,38	0	16
27	160	41,83	42,97	0	16
28	160	43,42	44,56	0	16
29	160	45,01	46,15	0	16

AT 10					
z	B	d <sub>k</sub>	d <sub>0</sub>	L	d
15	160	45,93	47,75	0	16
16	160	49,11	50,93	0	16
17	160	52,29	54,11	0	16
18	160	55,48	57,30	0	16
19	160	58,66	60,48	0	16
<hr/>					
20	160	61,84	63,66	0	20
21	160	65,03	66,85	0	20
22	160	68,21	70,03	0	20
23	160	71,39	73,21	0	20
24	160	74,57	76,39	0	20
<hr/>					
25	160	77,76	79,58	0	20
26	160	80,94	82,76	0	20
27	160	84,12	85,94	0	20
28	160	87,31	89,13	0	20
29	160	90,49	92,31	0	20



## AT-Profiles (AT 5, AT 10)

Pitch and widths [mm]

AT 5					
z	B	d <sub>k</sub>	d <sub>0</sub>	L	d
30	160	46,53	47,75	0	16
31	160	48,12	49,34	0	16
32	160	49,71	50,93	0	16
33	160	51,30	52,52	0	16
34	160	52,89	54,11	0	16
35	160	54,48	55,70	0	16
36	160	56,08	57,30	0	16
37	160	57,67	58,89	0	16
38	160	59,26	60,48	0	16
39	160	60,85	62,07	0	20
40	160	62,44	63,66	0	20
41	160	64,03	65,25	0	20
42	160	65,63	66,85	0	20
43	160	67,22	68,44	0	20
44	160	68,81	70,03	0	20
45	160	70,40	71,62	0	20
46	160	71,99	73,21	0	20
47	160	73,58	74,80	0	20
48	160	75,17	76,39	0	20
49	160	76,77	77,99	0	20
50	160	78,36	79,58	0	20
51	160	79,95	81,17	0	20
52	160	81,54	82,76	0	20
53	160	83,13	84,35	0	20
54	160	84,72	85,94	0	20
55	160	86,32	87,54	0	20
56	160	87,91	89,13	0	20
57	160	89,50	90,72	0	20
58	160	91,09	92,31	0	20
59	160	92,68	93,90	0	20
60	160	94,27	95,49	0	20
61	160	95,86	97,08	0	20
62	160	97,46	98,68	0	20
63	160	99,05	100,27	0	20
64	160	100,64	101,86	0	30
65	160	102,23	103,45	0	30
66	160	103,82	105,04	0	30
67	160	105,41	106,63	0	30
68	160	107,01	108,23	0	30
69	160	108,60	109,82	0	30

AT 10					
z	B	d <sub>k</sub>	d <sub>0</sub>	L	d
30	160	93,67	95,49	0	20
31	160	96,86	98,68	0	20
32	160	100,04	101,86	0	20
33	160	103,22	105,04	0	30
34	160	106,41	108,23	0	30
35	160	109,59	111,41	0	30
36	160	112,77	114,59	0	30
37	160	115,95	117,77	0	30
38	160	119,14	120,96	0	30
39	160	122,32	124,14	0	30
40	160	125,50	127,32	0	30
41	160	128,69	130,51	0	30
42	160	131,87	133,69	0	30
43	160	135,05	136,87	0	30
44	160	138,24	140,06	0	30
45	160	141,42	143,24	0	30
46	160	144,60	146,42	0	30
47	160	147,79	149,61	0	30
48	160	150,97	152,79	0	30
49	160	154,15	155,97	0	30
50	160	157,33	159,15	0	30
51	160	160,52	162,34	0	36
52	160	163,70	165,52	0	36
53	160	166,88	168,70	0	36
54	160	170,07	171,89	0	36
55	160	173,25	175,07	0	36
56	160	176,43	178,25	0	36
57	160	179,62	181,44	0	36
58	160	182,80	184,62	0	36
59	160	185,98	187,80	0	36
60	160	189,17	190,99	0	36
61	160	192,35	194,17	0	36
62	160	195,53	197,35	0	36
63	160	198,72	200,54	0	36
64	160	201,90	203,72	0	36
65	160	205,08	206,90	0	36
66	160	208,26	210,08	0	36
67	160	211,45	213,27	0	36
68	160	214,63	216,45	0	36
69	160	217,81	219,63	0	36

# Timing pulley bars with hubs

## T-Profile (T 2.5, T 5, T 10)

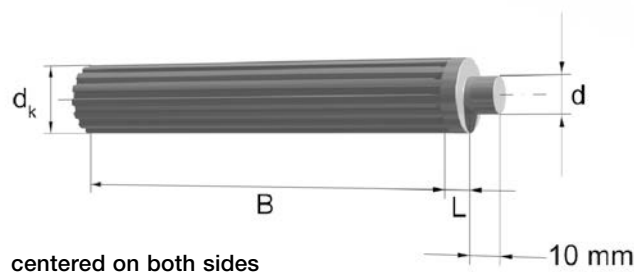

### Order example Timing pulley bars with hubs

Material SW 160 T 5 - 0 / 24

Width \_\_\_\_\_

Type / pitch \_\_\_\_\_

Toothform variant \_\_\_\_\_

Number of teeth \_\_\_\_\_

**Material:** AlCu4MgSi, RoHS-conformant

#### Tooth gaps:

- Normal gap (Standard, no order code necessary)
- SE gap (order code: -SE),
- Zero gap (order code: -0)

- z = Number of teeth
- B = Width [mm]
- d<sub>k</sub> = Outside diameter
- d<sub>0</sub> = Pitch circle diameter
- L = non-toothed length of shaft
- d = hub diameter

#### Pitch and widths [mm]

T 2.5						T 5						T 10					
z	B	d <sub>k</sub>	d <sub>0</sub>	L	d	z	B	d <sub>k</sub>	d <sub>0</sub>	L	d	z	B	d <sub>k</sub>	d <sub>0</sub>	L	d
15	50	11,40	11,94	25	6	15	132	23,05	23,87	0	10	15	160	45,90	47,75	0	16
16	50	12,20	12,73	25	6	16	140	24,60	25,46	0	10	16	160	49,05	50,93	0	16
17	50	13,00	13,53	25	6	17	140	26,20	27,06	0	10	17	160	52,25	54,11	0	16
18	50	13,80	14,32	25	6	18	140	27,80	28,65	0	10	18	160	55,45	57,30	0	16
19	90	14,60	15,12	30	8	19	140	29,40	30,24	0	10	19	160	58,60	60,48	0	16
20	90	15,40	15,92	30	8	20	160	31,00	31,83	0	12	20	160	61,60	63,66	0	20
21	90	16,20	16,71	30	8	21	160	32,70	33,42	0	12	21	160	65,00	66,85	0	20
22	90	17,00	17,51	30	8	22	160	34,25	35,01	0	12	22	160	68,15	70,03	0	20
23	90	17,80	18,30	30	8	23	160	35,85	36,61	0	12	23	160	71,35	73,21	0	20
24	125	18,55	19,10	15	10	24	160	37,40	38,20	0	12	24	160	74,55	76,39	0	20
25	125	19,35	19,89	15	10	25	160	39,00	39,79	0	12	25	160	77,75	79,58	0	20
26	125	20,15	20,69	15	10	26	160	40,60	41,38	0	16	26	160	80,90	82,76	0	20
27	125	20,95	21,49	15	10	27	160	42,20	42,97	0	16	27	160	84,10	85,94	0	20
28	125	21,75	22,28	15	10	28	160	43,75	44,56	0	16	28	160	87,25	89,13	0	20
29	125	22,55	23,08	15	10	29	160	45,35	46,15	0	16	29	160	90,45	92,31	0	20

## T-Profile (T 2.5, T 5, T 10)

Pitch and widths [mm]

T 2.5						T 5						T 10					
z	B	d <sub>k</sub>	d <sub>0</sub>	L	d	z	B	d <sub>k</sub>	d <sub>0</sub>	L	d	z	B	d <sub>k</sub>	d <sub>0</sub>	L	d
30	125	23,35	23,87	15	10	30	160	46,90	47,75	0	16	30	1160	93,65	95,49	0	20
31	125	24,15	24,67	15	10	31	160	48,50	49,34	0	16	31	160	96,80	98,68	0	20
32	125	24,95	25,46	15	10	32	160	50,10	50,93	0	16	32	160	100,00	101,86	0	20
33	125	25,75	26,26	15	10	33	160	51,70	52,52	0	16	33	160	103,20	105,04	0	30
34	125	26,55	27,06	15	10	34	160	53,30	54,11	0	16	34	160	106,35	108,23	0	30
35	132	27,35	27,85	8	10	35	160	54,85	55,70	0	16	35	160	109,55	111,41	0	30
36	132	28,15	28,65	8	10	36	160	56,45	57,30	0	16	36	160	112,75	114,59	0	30
37	132	28,90	29,44	8	10	37	160	58,05	58,89	0	16	37	160	115,90	117,77	0	30
38	132	29,70	30,24	8	10	38	160	59,65	60,48	0	16	38	160	119,10	120,96	0	30
39	132	30,50	31,04	8	10	39	160	61,25	62,07	0	20	39	160	122,30	124,14	0	30
40	132	31,30	31,83	8	12	40	160	62,85	63,66	0	20	40	160	125,45	127,32	0	30
41	132	32,10	32,63	8	12	41	160	64,40	65,25	0	20	41	160	128,65	130,51	0	30
42	140	32,90	33,42	0	12	42	160	66,00	66,85	0	20	42	160	131,85	133,69	0	30
43	140	33,70	34,22	0	12	43	160	67,60	68,44	0	20	43	160	135,00	136,87	0	30
44	140	34,50	35,01	0	12	44	160	69,20	70,03	0	20	44	160	138,20	140,06	0	30
45	140	35,30	35,81	0	12	45	160	70,80	71,62	0	20	45	160	141,40	143,24	0	30
46	140	36,10	36,61	0	12	46	160	72,40	73,21	0	20	46	160	144,50	146,42	0	30
47	140	36,90	37,40	0	12	47	160	73,95	74,80	0	20	47	160	147,75	149,61	0	30
48	140	37,70	38,20	0	12	48	160	75,55	76,39	0	20	48	160	150,95	152,79	0	30
49	140	38,45	38,99	0	12	49	160	77,15	77,99	0	20	49	160	154,10	155,97	0	30
50	140	39,25	39,79	0	12	50	160	78,75	79,58	0	20	50	160	157,30	159,15	0	30
51	140	40,05	40,58	0	12	51	160	80,35	81,17	0	20	51	160	160,50	162,34	0	36
52	140	40,85	41,38	0	16	52	160	81,95	82,76	0	20	52	160	163,65	165,52	0	36
53	140	41,65	42,18	0	16	53	160	83,55	84,35	0	20	53	160	166,85	168,70	0	36
54	140	42,45	42,97	0	16	54	160	85,10	85,94	0	20	54	160	170,05	171,89	0	36
55	140	43,25	43,77	0	16	55	160	86,70	87,54	0	20	55	160	173,20	175,07	0	36
56	140	44,05	44,56	0	16	56	160	88,30	89,13	0	20	56	160	176,40	178,25	0	36
57	140	44,85	45,36	0	16	57	160	89,90	90,72	0	20	57	160	179,60	181,44	0	36
58	140	45,65	46,15	0	16	58	160	91,50	92,31	0	20	58	160	182,75	184,62	0	36
59	140	46,45	46,95	0	16	59	160	93,10	93,90	0	20	59	160	185,95	187,80	0	36
60	140	47,25	47,75	0	16	60	160	94,65	95,49	0	20	60	160	189,15	190,99	0	36
61	140	48,05	48,54	0	16	61	160	96,25	97,08	0	20	61	160	192,30	194,17	0	36
62	140	48,80	49,34	0	16	62	160	97,85	98,68	0	20	62	160	195,50	197,35	0	36
63	140	49,60	50,13	0	16	63	160	99,45	100,27	0	20	63	160	198,70	200,54	0	36
64	140	50,40	50,93	0	16	64	160	101,05	101,86	0	30	64	160	201,85	203,72	0	36
65	140	51,20	51,37	0	16	65	160	102,65	103,45	0	30	65	160	205,05	206,90	0	36
66	140	52,00	52,52	0	16	66	160	104,20	105,04	0	30	66	160	208,25	210,08	0	36
67	140	52,80	53,32	0	16	67	160	105,80	106,63	0	30	67	160	211,40	213,27	0	36
68	140	53,60	54,11	0	16	68	160	107,40	108,23	0	30	68	160	214,60	216,45	0	36
69	140	54,40	54,91	0	16	69	160	109,00	109,82	0	30	69	160	217,80	219,63	0	36

# Shaft locking elements for timing pulleys

## Timing pulley locking bushes

Cost reduction, material savings, simplified manufacturing processes and faster material throughput are factors which are already decided by the design and development stages. Keyways, however, are often unable to fully meet everincreasing requirements. In these cases, locking bushes provide new options for attaching pulleys to shafts.

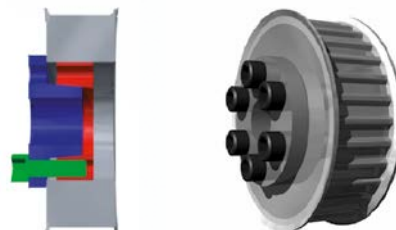

### Features and applications

- Bore diameter variations within the same outer diameter
- Single bore for the hub within the size range specified
- Fewer parts, reduced costs
- Axial retention
- Fast mounting – simplified manufacturing processes
- Ideal for drives experiencing frequently changing loads
- Permanent, non-destructive attachment
- Reusable

Locking bush for timing pulley.

### Design variants

Locking bushes come in many various designs. Please ask for our advice in choosing the most suitable locking bush.

### Availability

Locking bushes are readily available from stock.

### Assembled units

We can provide pre-assembled timing pulleys and locking bushes upon request.



## ATEF-X

### Shaft-to-timing pulley locking bushes up to 5mm pitch

ATEF-X is an innovative fastener for perfect shaft-to-timing pulley connection. Small size makes the ATEF-X a good choice for even small timing pulleys. The ATEF-X self-locking tapered design as well as its low radial run-out makes for a secure connection and warrants that belts will run smoothly.

Installation is easy: just slip the pre-assembled ATEF-X and timing pulley onto the shaft. The assembly between shaft and timing pulley is then secured by tightening the nut. To readjust the assembly, simply loosen the nut - which will come off easily even after long periods of operation.

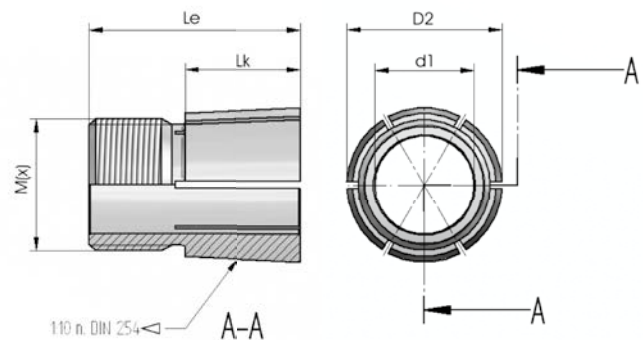

For data sheets see [www.atef-x.de](http://www.atef-x.de)

#### Technical data

Material	preferably stainless steel 1.4104 (X12CrMoS 17) or 1.4305 (X10CrNiS18 9)
Concentricity	run-out tolerance 0.01 – 0.02
Surface roughness	Ra = 3.2 µm (shaft) Ra = 1.6 µm (cone)
Fit (bore)	d1 = H7 (in non-slotted area)

#### Order example:

Timing pulley	AL 20 T 2.5 / 30 - 2 x 15
Material	_____
Total width B <sub>N</sub>	_____
Type / pitch	_____
Number of teeth	_____
Number of flanges	_____
Shaft diameter (d1)	_____

The following ATEF-X variants are available from stock:

Shaft Ø mm (d1)	Max. pulley width mm
2	7,5
3	7,5
4	7,5/16
5	9/12/16
6	9/12/16/22/26
<hr/>	
1/4"	9/12/16/22/26
7	9/12/16/22/26
8	12/16/22/26/30
9	16/22/26/30
3/8"	16/22/26/30
<hr/>	
10	16/22/26/30
11	16/22/30
12	16/22/30

If necessary please specify hub dimensions.

Shaft Ø mm (d1)	Max. pulley width mm
14	16/22/30
15	16/22/30
16	16/22/30
17	16/22/30
18	16/22/30
<hr/>	
19	16/22/30
20	16/22/30/45
21	16/22/30/45
22	16/22/30/45
24	16/22/30/45
<hr/>	
25	22/30/45
28	22/30/45
30	22/30/45

Package includes nut similar to DIN 439, galvanized steel (Stainless steel at extra cost).

**Special versions upon request.**

# Tensioners

**Stock Program**  
**Type B, eccentric,**  
**toothed running surface**

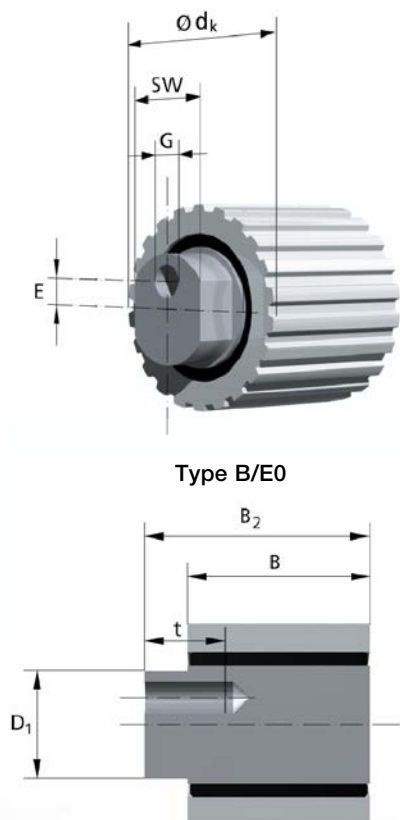

Type B/E0

Type B Mulco tensioners run on 2 ball bearings. The bearings are grease lubricated and up to 70 °C will experience no reduction in grease life. In the short term, temperatures up to 120 °C are allowable. Type B Mulco tensioners are made with high-quality German bearings.

**Order example:**

Mulco tensioner B/E0     Al 34 T 5 / 22 - 0

Width B \_\_\_\_\_

Type / pitch \_\_\_\_\_

Number of teeth \_\_\_\_\_

Number of flanges \_\_\_\_\_

**Materials:**

Shaft: Steel  
 Roller: Aluminium

Order code	Type	max. Belt width [mm]	B [mm]	$d_k / d_f$ *) [mm]	$B_2$ [mm]	E [mm]	G	
Mulco tensioner AI 34	T5/22-0	B/E0	25	34	34.15	42	5	M6
Mulco tensioner AI 34	AT5/22-0	B/E0	25	34	33.79	42	5	M6
Mulco tensioner AI 40	T10/20-0	B/E0	32	40	61.80	50	5	M12
Mulco tensioner AI 40	AT10/20-0	B/E0	32	40	61.84	50	5	M12
Mulco tensioner AI 64	T10/20-0	B/E0	50	64	61.80	74	5	M12
Mulco tensioner AI 64	AT10/20-0	B/E0	50	64	61.84	74	5	M12

\*) T-Profiles  $d_k$  / AT-Profiles  $d_f$

Continuation Order code	Type	t [mm]	D [mm]	SW [mm]	Loadbearing parameters		max. Rotational speeds n [mm <sup>-1</sup> ]	
					$C_{dyn}$ [N]	$C_{stat.}$ [N]		
Mulco tensioner AI 34	T5/22-0	B/E0	10	20	17	7950	3920	30000
Mulco tensioner AI 34	AT5/22-0	B/E0	10	20	17	7950	3920	15000
Mulco tensioner AI 40	T10/20-0	B/E0	20	30	27	19300	13100	30000
Mulco tensioner AI 40	AT10/20-0	B/E0	20	30	27	19300	13100	15000
Mulco tensioner AI 64	T10/20-0	B/E0	20	30	27	19300	13100	15000
Mulco tensioner AI 64	AT10/20-0	B/E0	20	30	27	19300	13100	15000

# Tensioners

**Stock Program**  
**Type B, eccentric,**  
**smooth running surface**

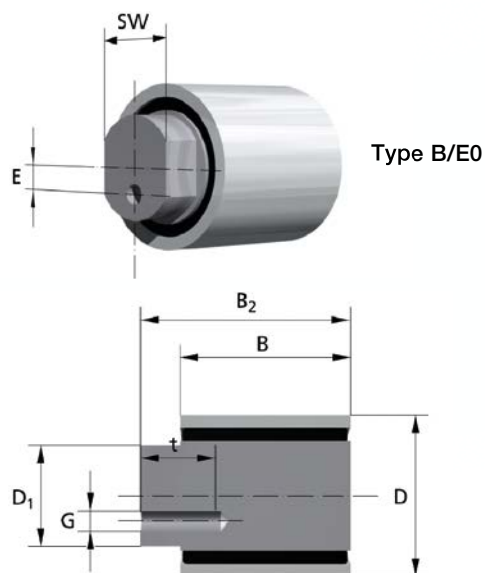

Type B Mulco tensioners run on 2 ball bearings. The bearings are grease lubricated and up to 70 °C will experience no reduction in grease life. In the short term, temperatures up to 120 °C are allowable.

**Order example:**

Mulco tensioner B/E0 70 / 120 - 0  
 Width B \_\_\_\_\_  
 Diameter D \_\_\_\_\_  
 Number of flanges \_\_\_\_\_

**Materials:**

Shaft: Steel  
 Roller: Aluminium  
 Flanges: Aluminium

Order code	Type	max. Belt width [mm]	B [mm]	D [mm]	d <sub>B</sub> [mm]	B <sub>2</sub> [mm]	E [mm]
Mulco tensioner B 34/32-0	B/E0	25	34	32	-	42	5
Mulco tensioner B 34/32-2	B/E2	25	34	32	41.5	42	5
Mulco tensioner B 40/60-0	B/E0	32	40	60	-	50	5
Mulco tensioner B 40/60-2	B/E2	32	40	60	71	50	5
Mulco tensioner B 64/60-0	B/E0	50	64	60	-	74	5
Mulco tensioner B 64/60-2	B/E2	50	64	60	71	74	5
Mulco tensioner B 40/80-0	B/E0	32	40	80	-	50	5
Mulco tensioner B 40/80-2	B/E2	32	40	80	91	50	5
Mulco tensioner B 64/80-0	B/E0	50	64	80	-	74	5
Mulco tensioner B 64/80-2	B/E2	50	64	80	91	74	5
Mulco tensioner B 90/80-0	B/E0	75	90	80	-	110	5
Mulco tensioner B 90/80-2	B/E2	75	90	80	91	110	5
Mulco tensioner B 40/120-0	B/E0	32	40	120	-	50	5
Mulco tensioner B 40/120-2	B/E2	32	40	120	132	50	5
Mulco tensioner B 64/120-0	B/E0	50	64	120	-	74	5
Mulco tensioner B 64/120-2	B/E2	50	64	120	132	74	5
Mulco tensioner B 70/120-0	B/E0	50	70	120	-	85	5
Mulco tensioner B 70/120-2	B/E2	50	70	120	137	85	5
Mulco tensioner B 90/120-0	B/E0	75	90	120	-	110	5
Mulco tensioner B 90/120-2	B/E2	75	90	120	137	110	5
Mulco tensioner B 40/150-0	B/E0	32	40	150	-	50	5
Mulco tensioner B 40/150-2	B/E2	32	40	150	162	50	5
Mulco tensioner B 64/150-0	B/E0	50	64	150	-	74	5
Mulco tensioner B 64/150-2	B/E2	50	64	150	162	74	5
Mulco tensioner B 90/150-0	B/E0	75	90	150	-	110	5
Mulco tensioner B 90/150-2	B/E2	75	90	150	162	110	5



**Stock program**  
**Type B, eccentric**  
**smooth running surface**

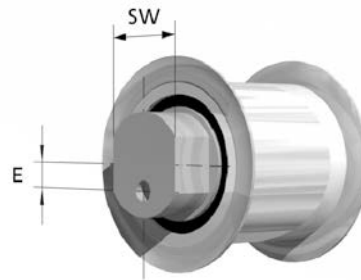
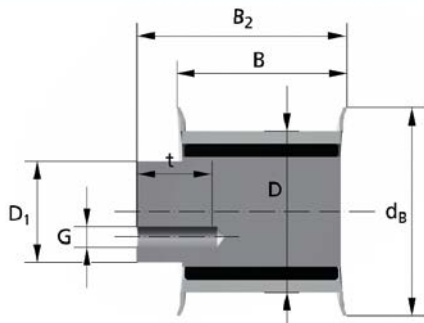

Type B/E2

G	t [mm]	SW [mm]	D <sub>1</sub> [mm]	Loadbearing parameters		max. Rotational speeds n [min <sup>-1</sup> ]
				C <sub>dyn.</sub> [N]	C <sub>stat.</sub> [N]	
M6	10	17	20	7950	3920	10000
M6	10	17	20	7950	3920	10000
M12	20	27	30	19300	13100	5000
M12	20	27	30	19300	13100	5000
M12	20	27	30	19300	13100	5000
M12	20	27	30	19300	13100	5000
M12	20	27	30	19300	13100	5000
M12	20	27	30	19300	13100	5000
M12	20	27	30	19300	13100	5000
M12	20	27	30	19300	13100	5000
M20	32	36	45	48000	38000	5000
M20	32	36	45	48000	38000	5000
M12	20	27	30	19300	13100	5000
M12	20	27	30	19300	13100	5000
M12	20	27	30	19300	13100	5000
M12	20	27	30	19300	13100	5000
M12	20	27	30	19300	13100	5000
M20	30	36	45	70500	48000	5000
M20	30	36	45	70500	48000	5000
M20	32	36	45	48000	38000	5000
M20	32	36	45	48000	38000	5000
M12	20	27	30	19300	13100	5000
M12	20	27	30	19300	13100	5000
M12	20	27	30	19300	13100	5000
M12	20	27	30	19300	13100	5000
M20	32	36	45	48000	38000	5000
M20	32	36	45	48000	38000	5000

# Tensioners

## Stock Program

### Type B with flange, smooth running surface

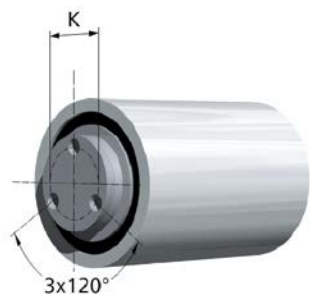

Type B/F0

#### Order example:

Mulco tensioner B/F2 117 / 180 - 2

Width B \_\_\_\_\_

Diameter D \_\_\_\_\_

Number of flanges \_\_\_\_\_

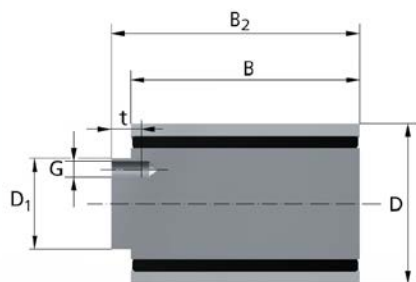

#### Materials:

Shaft: Steel  
 Roller: Aluminium  
 Flanges: Aluminium

Order code	Type	max. Belt width [mm]	B [mm]	D [mm]	d <sub>B</sub> [mm]	B <sub>2</sub> [mm]
Mulco tensioner B 114/60-0	B/F0	100	114	60	-	124
Mulco tensioner B 114/60-2	B/F2	100	114	60	71	124
Mulco tensioner B 114/80-0	B/F0	100	114	80	-	124
Mulco tensioner B 114/80-2	B/F2	100	114	80	91	124
Mulco tensioner B 70/120-0	B/F0	50	70	120	-	85
Mulco tensioner B 70/120-2	B/F2	50	70	120	137	85
Mulco tensioner B 90/120-0	B/F0	75	90	120	-	110
Mulco tensioner B 90/120-2	B/F2	75	90	120	137	110
Mulco tensioner B 117/120-0	B/F0	100	117	120	-	131
Mulco tensioner B 117/120-2	B/F2	100	117	120	137	131
Mulco tensioner B 70/180-0	B/F0	50	70	180	-	85
Mulco tensioner B 70/180-2	B/F2	50	70	180	204	85
Mulco tensioner B 90/180-0	B/F0	75	90	180	-	110
Mulco tensioner B 90/180-2	B/F2	75	90	180	204	110
Mulco tensioner B 117/180-0	B/F0	100	117	180	-	131
Mulco tensioner B 117/180-2	B/F2	100	117	180	204	131

**Stock Program**  
**Type B with flange, smooth running surface**

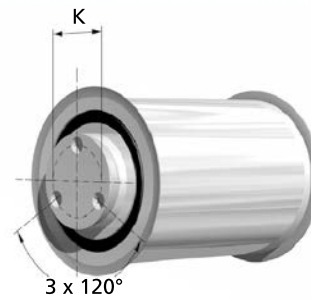
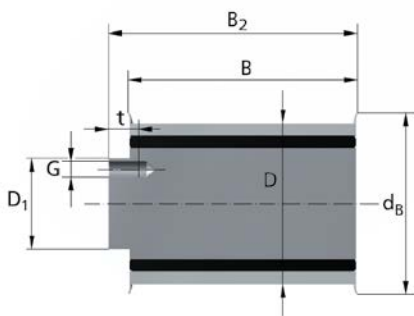

Type B/F2

K [mm]	G	t [mm]	D <sub>1</sub> [mm]	Loadbearing parameters		max. Rotational speeds n [min <sup>-1</sup> ]
				C <sub>dyn.</sub> [N]	C <sub>stat.</sub> [N]	
34	M8 (3x)	15	45	19300	13100	5000
34	M8 (3x)	15	45	19300	13100	5000
34	M8 (3x)	15	45	19300	13100	5000
34	M8 (3x)	15	45	19300	13100	5000
65	M12 (3x)	24	85	70500	48000	5000
65	M12 (3x)	24	85	70500	48000	5000
65	M12 (3x)	24	85	70500	48000	5000
65	M12 (3x)	24	85	70500	48000	5000
65	M12 (3x)	24	85	70500	48000	5000
65	M12 (3x)	25	106	70500	48000	5000
65	M12 (3x)	25	106	70500	48000	5000
80	M16 (3x)	25	106	106000	76000	5000
80	M16 (3x)	25	106	106000	76000	5000
80	M16 (3x)	25	106	106000	76000	5000
80	M16 (3x)	25	106	106000	76000	5000

# Tensioners

## Stock Program

### Type M heavy series, eccentric

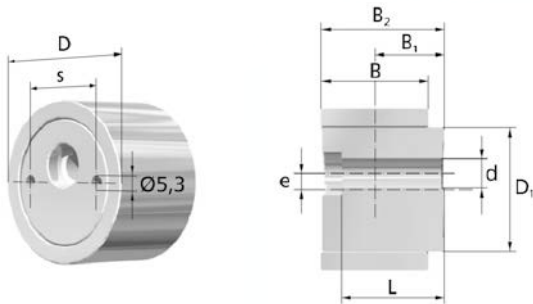

1 groove

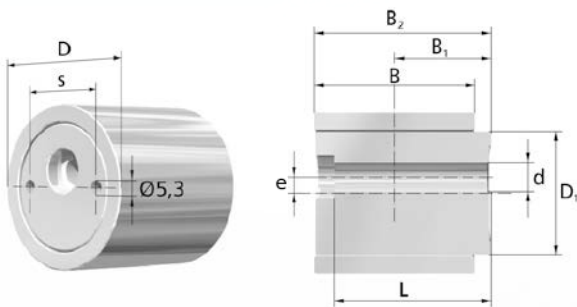

2 groove

The Type M Mulco tensioner is available in 7 standard sizes. The tensioners feature a rigid and vibration-resistant support structure and the belt loads are resisted by the generously sized base diameter  $D_1$ . The race and the support structures are made from AlCu4MgSi. The tensioners are mounted on the machine frame and the eccentric mount allows for easy adjustment of the belt pre-tension. For adjusting the mounting shaft, the pin spanner (pictured right) can be used.

The tensioners are fitted with high-quality ball bearings and pre-lubricated for life with lithium grease. They are short-time temperature resistant up to 120 °C and permanent temperatures from 70 °C and above will lead to a lower grease life than expected. The stated load ratings are based on the total tensioner where a central belt load is assumed.

Socket-head screws to DIN 6912 can be used for mounting to the machine frame. The screw length is dependant on proper construction in accordance with the mounting options and the associated environment. The thread sizes in the table use the recommended strength class of the screws provided.

Special sizes and tensioners with flanges on request.

Order code		Weight		Dimensions										Bearing type
		[kg]		B	B <sub>1</sub>	B <sub>2</sub>	D	D <sub>1</sub>	L	e	s	d	1 groove	2 groove
				[mm]	[mm]	[mm]	[mm]	[mm]	[mm]	[mm]	[mm]	[mm]		
Tensioner	BSR	71-100	0.06	14	16	23	28	17.5	-	-	-	-	1	
Tensioner	BSR	73-100	0.1	27	26	39.5	28	17.5	-	-	-	-	2	
Mulco tensioner	M	40 / 60-0	approx.	0.4	40	26	46	60	46	37.5	6	35	11	1
Mulco tensioner	M	60 / 60-0	approx.	0.5	60	36	66	60	46	57.5	6	35	11	2
Mulco tensioner	M	110 / 60-0	approx.	0.8	110	61	116	60	46	106.5	5	35	13	2
Mulco tensioner	M	60 / 120-0	approx.	2.4	60	35	70	120	94	57.5	17	70	17	2
Mulco tensioner	M	110 / 120-0	approx.	3.9	110	60	120	120	94	107.5	17	70	17	2
Mulco tensioner	M	85 / 180-0	approx.	7.0	85	45	95	180	137	78.5	30	70	26	2
Mulco tensioner	M	160 / 180-0	approx.	10.8	160	83	170	180	137	153.5	30	70	26	2

BSR71-100 and BSR73-100 tensioners are available in single and double row bearing versions, pre-lubricated to DIN 51852-K3K.

They are suitable as deflection and tension pulleys for light belt drives such as T 2.5 and T 5.

**Stock Program**

**Type BSR light series, non-eccentric**



Mounting instruction: counter-clockwise tensioning!

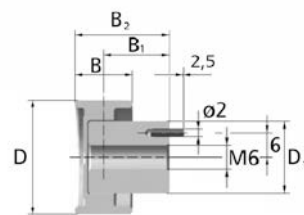

BSR 71-100

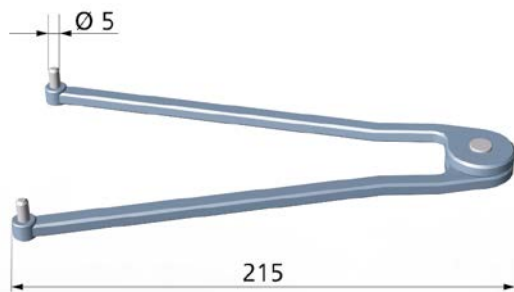

Pin spanner, Type 40 758

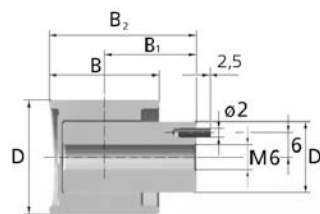

BSR 73-100



Loadbearing parameters		Rotational speed	Socket-head screw DIN 6912			Application recommendation*		
$C_{0 \text{ dyn.}}$ [N]	$C_{0 \text{ Stat.}}$ [N]	$n_{\text{max.}}$ [min <sup>-1</sup> ]	Size	Strength class	Torque [Nm]	max. belt width [mm]	Tension roller running on back of the belt	Tension roller running on back of the belt
4050	1710	8000	M 6	8.8	10	10	T2.5/T5	T2.5/T5/AT5
6200	3450	15000	M 6	8.8	10	25	T2.5/T5	T2.5/T5/AT5
11200	5600	15000	M 10	8.8	49	32	AT5/T10	AT10/T10
19300	11200	15000	M 10	10.9	69	50	AT5/T10	AT10/ATP10/T10
19300	11200	15000	M 12	12.9	145	100	AT5/T10	AT10/ATP10/T10
51000	36600	6700	M 16	8.8	210	50	AT10/ATP10/T20	AT20/ATP15
51000	36600	6700	M 16	12.9	355	100	AT10/ATP10/T20	AT20/ATP15
100000	78000	4800	M 24	8.8	710	75	AT20/ATP15	T20
100000	78000	4800	M 24	12.9	1200	150	AT20/ATP15	T20

\* For use with CONTI® SYNCHROCHAIN timing belts please ask our advice!



# Clamp plates

## Stock program

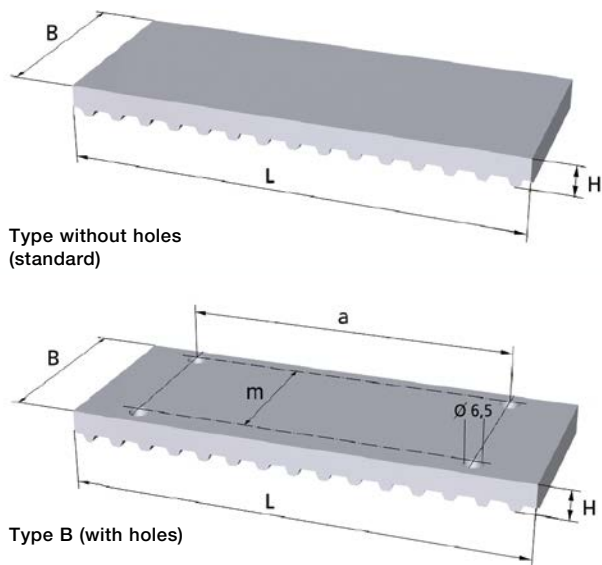

Clamp plates are often used in linear technology, when one or both belt ends need to be fixed to the housing.

An adjustment of the pretension is not possible with clamp plates.

### Order example:

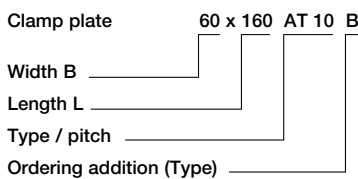

**Material:** AlMgSi 0,5

## AT-Profile

Order code	Belt code		Hole diameter d	m	a	H	
	B x L						
Clamp plate	30 x 75	AT 3	10 AT 3	5.5	20	50	8
Clamp plate	50 x 75	AT 3	20 AT 3	5.5	30	50	8
Clamp plate	60 x 75	AT 3	25 AT 3	5.5	38	50	8
Clamp plate	50 x 120	AT 5	25 AT 5	6.5	38	80	10
Clamp plate	60 x 120	AT 5	32 AT 5	6.5	46	80	10
Clamp plate	75 x 120	AT 5	50 AT 5	6.5	62	80	10
Clamp plate	110 x 120	AT 5	75 AT 5	6.5	94	80	10
Clamp plate	140 x 120	AT 5	100 AT 5	6.5	124	80	10
Clamp plate	50 x 160	AT 10	25 AT 10	6.5	38	110	10
Clamp plate	60 x 160	AT 10	32 AT 10	6.5	46	110	10
Clamp plate	75 x 160	AT 10	50 AT 10	6.5	62	110	10
Clamp plate	110 x 160	AT 10	75 AT 10	6.5	94	110	10
Clamp plate	140 x 160	AT 10	100 AT 10	6.5	124	110	10
Clamp plate	190 x 160	AT 10	150 AT 10	6.5	174	110	10
Clamp plate	50 x 200	AT 20	25 AT 20	6.5	38	160	20
Clamp plate	60 x 200	AT 20	32 AT 20	6.5	46	160	20
Clamp plate	75 x 200	AT 20	50 AT 20	6.5	62	160	20
Clamp plate	110 x 200	AT 20	75 AT 20	6.5	94	160	20
Clamp plate	140 x 200	AT 20	100 AT 20	6.5	124	160	20
Clamp plate	190 x 200	AT 20	150 AT 20	6.5	174	160	20
Clamp plate	50 x 160	BAT 10	25 BAT 10	6.5	38	110	10
Clamp plate	60 x 160	BAT 10	32 BAT 10	6.5	46	110	10
Clamp plate	75 x 160	BAT 10	50 BAT 10	6.5	62	110	10

## T-Profile

Order code	Belt code			Hole diameter d	m	a	H
	B x L						
Clamp plate	30 x 50	T 2.5	10 T 2.5	4.5	20	30	6
Clamp plate	40 x 60	T 2.5	20 T 2.5	4.5	30	30	6
Clamp plate	50 x 120	T 5	25 T 5	6.5	38	80	10
Clamp plate	60 x 120	T 5	32 T 5	6.5	46	80	10
Clamp plate	75 x 120	T 5	50 T 5	6.5	62	80	10
Clamp plate	110 x 120	T 5	75 T 5	6.5	94	80	10
Clamp plate	140 x 120	T 5	100 T 5	6.5	124	80	10
Clamp plate	50 x 160	T 10	25 T 10	6.5	38	110	10
Clamp plate	60 x 160	T 10	32 T 10	6.5	46	110	10
Clamp plate	75 x 160	T 10	50 T 10	6.5	62	110	10
Clamp plate	110 x 160	T 10	75 T 10	6.5	94	110	10
Clamp plate	140 x 160	T 10	100 T 10	6.5	124	110	10
Clamp plate	190 x 160	T 10	150 T 10	6.5	174	110	10
Clamp plate	50 x 200	T 20	25 T 20	6.5	38	160	20
Clamp plate	60 x 200	T 20	32 T 20	6.5	46	160	20
Clamp plate	75 x 200	T 20	50 T 20	6.5	62	160	20
Clamp plate	110 x 200	T 20	75 T 20	6.5	94	160	20
Clamp plate	140 x 200	T 20	100 T 20	6.5	124	160	20
Clamp plate	190 x 200	T 20	150 T 20	6.5	174	160	20

## Imperial-Profile

Order code	Belt code			Hole diameter d	m	a	H
	B x L						
Clamp plate	50 x 120	T 1/5"	25.4 T 1/5"	6.5	38	80	10
Clamp plate	60 x 120	T 1/5"	38.1 T 1/5"	6.5	46	80	10
Clamp plate	75 x 120	T 1/5"	50.8 T 1/5"	6.5	62	80	10
Clamp plate	110 x 120	T 1/5"	76.2 T 1/5"	6.5	94	80	10
Clamp plate	50 x 160	T 3/8"	25.4 T 3/8"	6.5	38	110	10
Clamp plate	60 x 160	T 3/8"	38.1 T 3/8"	6.5	46	110	10
Clamp plate	75 x 160	T 3/8"	50.8 T 3/8"	6.5	62	110	10
Clamp plate	110 x 160	T 3/8"	76.2 T 3/8"	6.5	94	110	10
Clamp plate	50 x 160	T 1/2"	25.4 T 1/2"	6.5	38	110	10
Clamp plate	60 x 160	T 1/2"	38.1 T 1/2"	6.5	46	110	10
Clamp plate	75 x 160	T 1/2"	50.8 T 1/2"	6.5	62	110	10
Clamp plate	110 x 160	T 1/2"	76.2 T 1/2"	6.5	94	110	10
Clamp plate	140 x 160	T 1/2"	101.6 T 1/2"	6.5	124	110	10
Clamp plate	50 x 200	T 7/8"	25.4 T 7/8"	6.5	38	160	20
Clamp plate	60 x 200	T 7/8"	38.1 T 7/8"	6.5	46	160	20
Clamp plate	75 x 200	T 7/8"	50.8 T 7/8"	6.5	62	160	20
Clamp plate	110 x 200	T 7/8"	76.2 T 7/8"	6.5	94	160	20
Clamp plate	140 x 200	T 7/8"	101.6 T 7/8"	6.5	124	160	20

# Clamp plates

## Clamp plate for belt clamping on one side

### AT, T-Profile

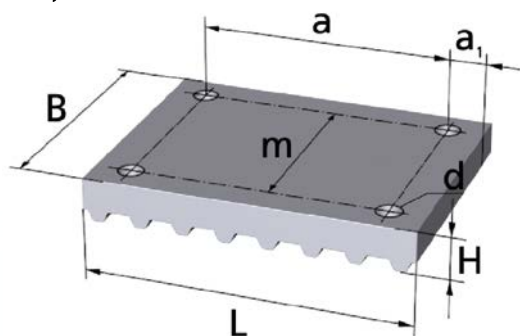

### Order example:

Clamp plate 60 x 78 AT 10  
 Width B  
 Length L  
 Type / pitch

**Material:** AlMgSi 0,5

### AT-Profile

Order code	Belt code		m	a	a <sub>1</sub>	H	Diameter d	
	B x L							
Clamp plate	50 x 58	AT 5	25 AT 5	35	30	15	10	5.5
Clamp plate	60 x 58	AT 5	32 AT 5	42	30	15	10	5.5
Clamp plate	75 x 58	AT 5	50 AT 5	60	30	15	10	5.5
Clamp plate	110 x 58	AT 5	75 AT 5	90	30	15	10	5.5
Clamp plate	50 x 78	AT 10	25 AT 10	35	40	20	10	5.5
Clamp plate	60 x 78	AT 10	32 AT 10	42	40	20	10	5.5
Clamp plate	75 x 78	AT 10	50 AT 10	60	40	20	10	5.5
Clamp plate	110 x 78	AT 10	75 AT 10	90	40	20	10	5.5
Clamp plate	50 x 98	AT 20	25 AT 20	35	60	20	20	9
Clamp plate	60 x 98	AT 20	32 AT 20	42	60	20	20	9
Clamp plate	75 x 98	AT 20	50 AT 20	60	60	20	20	9
Clamp plate	110 x 98	AT 20	75 AT 20	90	60	20	20	9

### T-Profile

Order code	Belt code		m	a	a <sub>1</sub>	H	Diameter d	
	B x L							
Clamp plate	50 x 58	T 5	25 T 5	35	30	15	10	5.5
Clamp plate	60 x 58	T 5	32 T 5	42	30	15	10	5.5
Clamp plate	75 x 58	T 5	50 T 5	60	30	15	10	5.5
Clamp plate	110 x 58	T 5	75 T 5	90	30	15	10	5.5
Clamp plate	50 x 78	T 10	25 T 10	35	40	20	10	5.5
Clamp plate	60 x 78	T 10	32 T 10	42	40	20	10	5.5
Clamp plate	75 x 78	T 10	50 T 10	60	40	20	10	5.5
Clamp plate	110 x 78	T 10	75 T 10	90	40	20	10	5.5
Clamp plate	50 x 98	T 20	25 T 20	35	60	20	20	9
Clamp plate	60 x 98	T 20	32 T 20	42	60	20	20	9
Clamp plate	75 x 98	T 20	50 T 20	60	60	20	20	9
Clamp plate	110 x 98	T 20	75 T 20	90	60	20	20	9

## Clamp plate for belt clamping on one side

HTD profile

## Order example:

Clamp plate 60 x 78 8M  
 Width B  
 Length L  
 Type / pitch

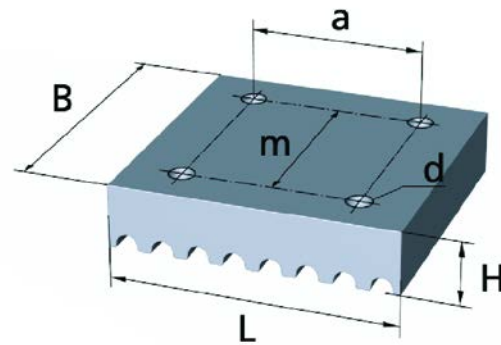

Material: AlMgSi 0,5

## HTD-Profile

Order code	Belt code		m	a	H	Diameter d	
	B	L					
Clamp plate	28 x 41.8	5M	10 5M	16	25	8	5.5
Clamp plate	34 x 41.8	5M	15 5M	22	25	8	5.5
Clamp plate	44 x 41.8	5M	25 5M	32	25	8	5.5
Clamp plate	45 x 66	8M	20 8M	29	40	15	9
Clamp plate	55 x 66	8M	30 8M	39	40	15	9
Clamp plate	75 x 66	8M	50 8M	59	40	15	9
Clamp plate	110 x 66	8M	85 8M	94	40	15	9
Clamp plate	71 x 116	14M	40 14M	51	70	22	11
Clamp plate	86 x 116	14M	55 14M	66	70	22	11
Clamp plate	116 x 116	14M	85 14M	96	70	22	11
Clamp plate	146 x 116	14M	115 14M	126	70	22	11
Clamp plate	201 x 116	14M	170 14M	181	70	22	11

# Guide rails

## Guide rails for polyurethane timing belt drives

BRECO®, BRECOFLEX® and CONTI SYNCHROFLEX® polyurethane timing belts have proven to be excellent mediums for transport. The motor force is reliably transmitted by the positive meshing of the belt teeth, the steel cord tension members transmit high tensile forces and the polyurethane belt material has low abrasion and wear resistant features.

### The guide rail

The weight of transported goods will deflect an unsupported belt span and guide rails are used to combat this. We offer guide rails with and without side guides depending on the design requirements. The coefficient of friction with the belt is low.

Our guide rails are available from a standard program coordinated with the available timing belt widths. The preferred length is 2000 mm. Parts less than 2000 mm are also available. Greater lengths and special sizes available to order.

Please contact your Mulco partner.

### Example belt-conveyor system

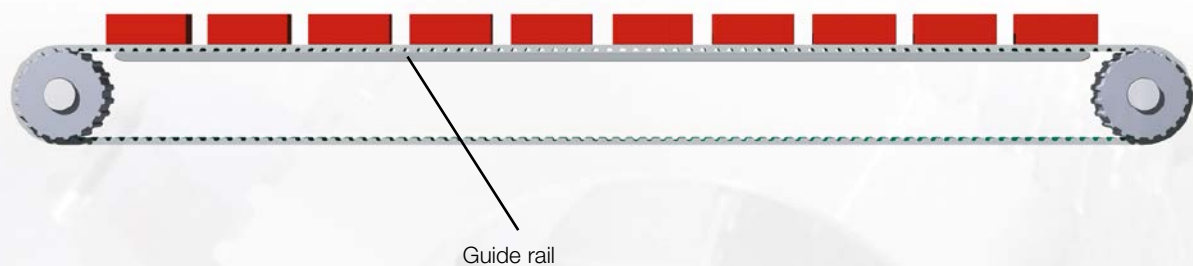



### Guide rails without side guides

Guide rails without side guides are universally applicable to all types of toothed belts from our product range. They are to be preferred where no large lateral forces act on the conveyor belt.

#### Order example:

Guide rail GC 50 / 1200  
 Type \_\_\_\_\_  
 For Belt width \_\_\_\_\_  
 Length in mm \_\_\_\_\_

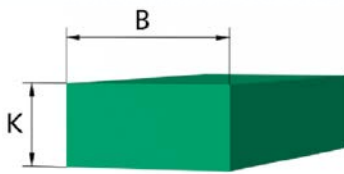

Type G

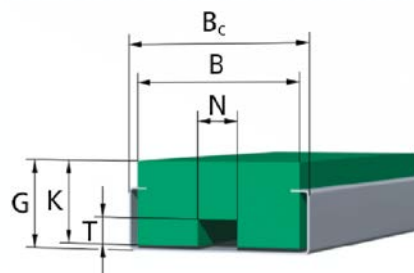

Type GC

Type	B	B <sub>c</sub>	K	G	N	T	for timing belt width
G 32	45	-	22	-	-	-	32
G 50	68	-	32	-	-	-	50
G 75	93	-	32	-	-	-	75
G 100	118	-	32	-	-	-	100
GC 32	45	50	22	23.5	11	7	32
GC 50	68	75	32	34.5	14	9	50
GC 75	93	100	32	34.5	14	9	75
GC100	118	125	32	34.5	14	9	100

# Guide rails

## Guide rails with side guides

Guide rails with side guides are preferred where large lateral forces act on the conveyor belt.

### Order example:

Guide rail **FC 50 x 4,5 / 1200**  
 Type \_\_\_\_\_  
 For Belt width x h \_\_\_\_\_  
 Length in mm \_\_\_\_\_

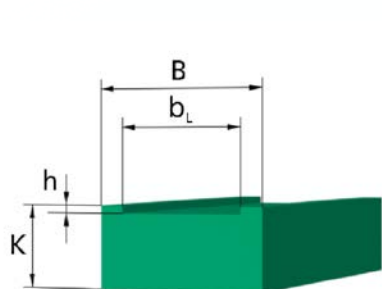

Type F

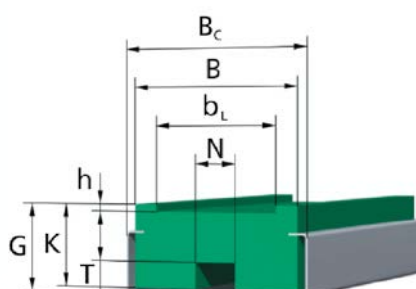

Type FC

Type	B	B <sub>C</sub>	b <sub>L</sub>	K	h	G	N	T	for timing belt width
F 32 x 2	45	-	33	22	2	-	-	-	32 AT 5 32 T 5
F 50 x 2	68	-	51	32	2	-	-	-	50 AT 5 50 T 5
F 75 x 2	93	-	76	32	2	-	-	-	75 AT 5 75 T 5
F 100x 2	118	-	101	32	2	-	-	-	100 AT 5 100 T 5
F 32 x 4	45	-	33	22	4	-	-	-	32 AT 10 32 T 10
F 50 x 4	68	-	51	32	4	-	-	-	50 AT 10 50 T 10
F 75 x 4	93	-	76	32	4	-	-	-	75 AT 10 75 T 10
F 100x 4	118	-	101	32	4	-	-	-	100 AT 10 100 T 10
F 50 x 7	68	-	51	32	7	-	-	-	50 AT 20 50 T 20
F 75 x 7	93	-	76	32	7	-	-	-	75 AT 20 75 T 20
F 100x 7	118	-	101	32	7	-	-	-	100 AT 20 100 T 20
FC 32 x 2	45	50	33	22	2	23.5	11	7	32 AT 5 32 T 5
FC 50 x 2	68	75	51	32	2	34.5	14	9	50 AT 5 50 T 5
FC 75 x 2	93	100	76	32	2	34.5	14	9	75 AT 5 75 T 5
FC 100x 2	118	125	101	32	2	34.5	14	9	100 AT 5 100 T 5
FC 32 x 4	45	50	33	22	4	23.5	11	7	32 AT 10 32 T 10
FC 50 x 4	68	75	51	32	4	34.5	14	9	50 AT 10 50 T 10
FC 75 x 4	93	100	76	32	4	34.5	14	9	75 AT 10 75 T 10
FC 100x 4	118	125	101	32	4	34.5	14	9	100 AT 10 100 T 10
FC 50 x 7	68	75	51	32	7	34.5	14	9	50 AT 20 50 T 20
FC 75 x 7	93	100	76	32	7	34.5	14	9	75 AT 20 75 T 20
FC 100x 7	118	125	101	32	7	34.5	14	9	100 AT 20 100 T 20

## Guide rails with V-guide

Guide rails with V-guide are used with self-tracking belts.  
 Guide rails for ATN belts can be supplied with a V-guide upon request.

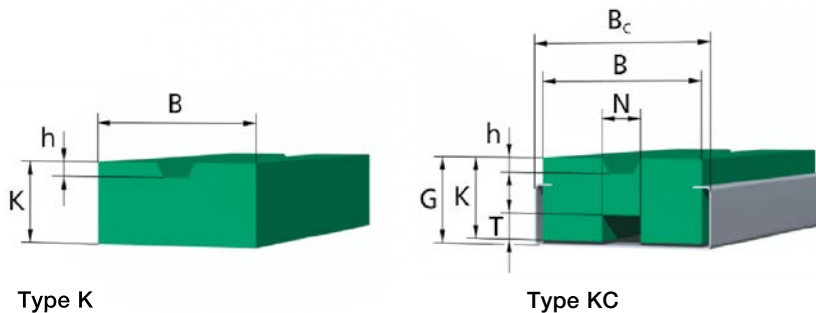

Type K

Type KC

### Order example:

Guide rail **K13-C 32 x 4,5 / 1200**  
 Type \_\_\_\_\_  
 For Belt width x h \_\_\_\_\_  
 Length in mm \_\_\_\_\_

Type	B	B <sub>c</sub>	K	h	G	N	T	for timing belt width		
K6	32 x 4	45	-	22	4	-	-	-	32 ATK5 K6	32 TK5 K6
K6	50 x 4	68	-	32	4	-	-	-	50 ATK5 K6	50 TK5 K6
K6	32 x 2	45	-	32	2	-	-	-	32 ATK10 K6	32 TK10 K6
K6	50 x 2	68	-	32	2	-	-	-	50 ATK10 K6	50 TK10 K6
K6	75 x 2	93	-	32	2	-	-	-	75 ATK10 K6	75 TK10 K6
K6	100 x 2	118	-	32	2	-	-	-	100 ATK10 K6	100 TK10 K6
K13	32 x 4,5	45	-	22	4,5	-	-	-	32 ATK10 K13	32 TK10 K13
K13	50 x 4,5	68	-	32	4,5	-	-	-	50 ATK10 K13	50 TK10 K13
K13	75 x 4,5	93	-	32	4,5	-	-	-	75 ATK10 K13	75 TK10 K13
K13	100 x 4,5	118	-	32	4,5	-	-	-	100 ATK10 K13	100 TK10 K13
K13	50 x 2	68	-	32	2	-	-	-	50 ATK20 K13	50 TK20 K13
K13	75 x 2	93	-	32	2	-	-	-	75 ATK20 K13	75 TK20 K13
K13	100 x 2	118	-	32	2	-	-	-	100 ATK20 K13	100 TK20 K13
K6-C	32 x 4	45	50	22	4	23,5	11	7	32 ATK5 K6	32 TK5 K6
K6-C	50 x 4	68	75	32	4	34,5	14	9	50 ATK5 K6	50 TK5 K6
K6-C	32 x 2	45	50	32	2	23,5	11	7	32 ATK10 K6	32 TK10 K6
K6-C	50 x 2	68	75	32	2	34,5	14	9	50 ATK10 K6	50 TK10 K6
K6-C	75 x 2	93	100	32	2	34,5	14	9	75 ATK10 K6	75 TK10 K6
K6-C	100 x 2	118	125	32	2	34,5	14	9	100 ATK10 K6	100 TK10 K6
K13-C	32 x 4,5	45	50	22	4,5	23,5	11	7	32 ATK10 K13	32 TK10 K13
K13-C	50 x 4,5	68	75	32	4,5	34,5	14	9	50 ATK10 K13	50 TK10 K13
K13-C	75 x 4,5	93	100	32	4,5	34,5	14	9	75 ATK10 K13	75 TK10 K13
K13-C	100 x 4,5	118	125	32	4,5	34,5	14	9	100 ATK10 K13	100 TK10 K13
K13-C	50 x 2	68	75	32	2	34,5	14	9	50 ATK20 K13	50 TK20 K13
K13-C	75 x 2	93	100	32	2	34,5	14	9	75 ATK20 K13	75 TK20 K13
K13-C	100 x 2	118	125	32	2	34,5	14	9	100 ATK20 K13	100 TK20 K13

# Mulco b@lt-pilot

## Your direct road to perfect design solutions

### Mulco belt-pilot – online support at [www.mulco.net](http://www.mulco.net)

Let others talk about being close to the customer, we as the market leading provider of polyurethane timing belts actually live by the idea. Mulco-Europe EWIV's secret of success has always been largely due to advising our customers before they enter the design stage. Mulco belt-pilot is taking our customer dedication a critical step further ahead. Our interactive Internet service offering enables you to calculate your personal design solutions online. Whatever field of technology you are interested in - power transmission, linear, transport or components - start Mulco belt-pilot at [www.mulco.net](http://www.mulco.net) for 24/7 access to the actual product information, CAD downloads and calculations you need.

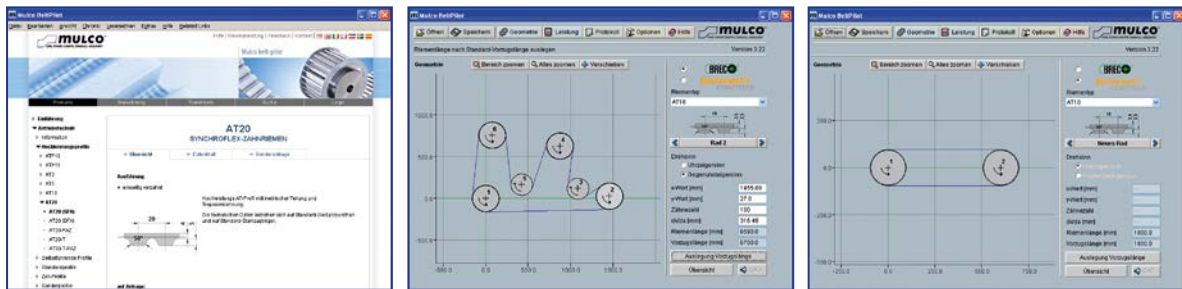

## Mulco b@lt-pilot

### Many benefits.

- ▶ Interactive service offering with video-based e-learning option
- ▶ Extensive product databases
- ▶ Free use of CAD downloads
- ▶ Import the CAD drawings into your CAD system
- ▶ Calculate timing belts, pulleys and components
- ▶ Email inquiries supported





# Polyurethane timing belt welder

## Welds what belongs together

### The portable TSG 4 welder – ready for a quick change

Even top-quality products will eventually wear out. The same applies to polyurethane timing belts which, from time to time, need to be replaced. We designed the portable TSG welder to assist you in replacing drive units that take a lot of mounting effort and are difficult to access due to upstream machine components. The portable TSG welder is easy to operate and allows you to weld polyurethane timing belts onsite, immediately in or at the machine. The TSG 4 welding unit is available in two versions: for belt widths up to 50 mm and for belt widths up to 100 mm.



#### One welder, many benefits

- Suitable for all timing belt profiles
- Short machine downtimes
- Easy to operate
- Flexible through long power cords
- Welds and cools down in as little as about 30 minutes
- Air-cooled, no water supply required
- Powerful heater output

#### Standard package

- Welder with belt-specific, replaceable weld face
- Control unit for automatic welding and cooling down
- Control unit and welder connect by metal-reinforced cable
- Transport case with tools



#### Technical data TSG 4 - 50

Operating voltage: 230 V/50 Hz

Power consumption: 1.2 kW

Welder dimensions:

W 240 mm x H 220 mm x D 170 mm

Welder weight: approx. 7.5 kg\*

Control unit dimensions:

Type-III/TSG MR 10

W 350 mm x H 166 mm x D 355 mm

Control unit weight: approx. 9.0 kg

Carrying case weight: approx. 6.0 kg

#### Technical data TSG 4 - 100

Operating voltage: 230 V/50 Hz

Power consumption: 2 kW

Welder dimensions:

W 240 mm x H 220 mm x D 220 mm

Welder weight: approx. 9.5 kg\*

Control unit dimensions:

Type-III/TSG MR 10

B 350 mm x H 166 mm x D 355 mm

Control unit weight: approx. 9.0 kg

Carrying case weight: approx. 6.0 kg

\* including connecting leads

#### Special accessories

- Hydraulic punch
- Weld jigs for all standard belt profiles
- Punch box
- All units available separately





# List of Catalogues

All our information at a glance

## Polyurethane Timing Belts

BRECO®, BRECOFLEX® timing belts  
BRECO®, BRECOFLEX® – Processing of timing belts  
BRECO®, BRECOFLEX® flat belts  
BRECO® ATN-system  
BRECOprotect® – Timing Belts  
BRECObasic® – Timing Belts

CONTI® SYNCHROFLEX Polyurethane Timing Belts. Overall catalog  
CONTI® SYNCHROCHAIN/SYNCHROCHAIN CARBON Heavy-Duty Timing Belts  
CONTI® SYNCHRODRIVE Polyurethane Synchronous Drive Belts  
CONTI® SYNCHRODRIVE N10 Nubbed Belt  
CONTI® POLYFLAT PU Flat Belts

## Pulleys and Accessories

PULLEYS & COMPONENTS for polyurethane timing belt drives  
Portable TSG 4 welder for polyurethane timing belts

**All product information  
can be requested from  
your Mulco Partner.**

**New information material  
available for download at  
[www.mulco.net](http://www.mulco.net)**



MULCO® is a registered trademark of  
Wilhelm Herm. Müller GmbH & Co. KG,  
Heinrich-Nordhoff-Ring 14, 30826 Garbsen, Germany.

© 2014 Mulco-Europe EWIV. All rights reserved.  
Reproduction of the entirety of text or parts prohibited.







ContiTech



## Sales partners Germany

**Hilger u. Kern Antriebstechnik**

Hilger u. Kern GmbH  
Antriebstechnik  
Käfertaler Straße 253  
68167 Mannheim  
Phone: +49 621 3705-0  
Fax: +49 621 3705-403  
e-mail: antriebstechnik@hilger-kern.de  
www.hilger-kern.com

**WILHELM HERM. MÜLLER**

Wilhelm Herm. Müller GmbH & Co. KG  
Heinrich-Nordhoff-Ring 14  
30826 Garbsen  
Phone: +49 5131 4522-0  
Fax: +49 5131 4522-110  
e-mail: info@whm.net  
www.whm.net



Roth GmbH & Co. KG  
Andernacher Straße 14  
90411 Nürnberg  
Phone: +49 911 99521-0  
Fax: +49 911 99521-70  
e-mail: info@roth-ing.de  
www.roth-ing.de



Anton Klocke Antriebstechnik GmbH  
Senner Straße 151  
33659 Bielefeld  
Phone: + 49 521 95005-01  
Fax: + 49 521 95005-11  
e-mail: info@klocke-antrieb.de  
www.klocke-antrieb.de



REIFF Technische Produkte GmbH  
Tübinger Straße 2-6  
72762 Reutlingen  
Phone: +49 7121 323-0  
Fax: +49 7121 323-318  
e-mail: zahnriemen@reiff-gruppe.de  
www.reiff-tp.de



Walter Rothermundt GmbH & Co. KG  
Am Tannenbaum 2  
41066 Mönchengladbach  
Phone: +49 2161 694620  
Fax: +49 2161 664469  
e-mail: info@rothermundt.de  
www.rothermundt.de

## Sales partner France



BINDER MAGNETIC  
1, Allée des Barbanniers  
92632 Gennevilliers Cedex  
France  
Phone: +33 1 461380-80  
Fax: +33 1 461380-99  
e-mail: info@binder-magnetic.fr  
www.binder-magnetic.fr

## Sales partner Sweden



Aratron AB  
Smidesvägen 4 – 8  
171 41 Solna  
Sweden  
Phone: +46 8 4041-600  
Fax: +46 8 984281  
e-mail: info@aratron.se  
www.aratron.se

## Sales partner Spain



Dinámica Distribuciones S.A.  
Ctra. N. II, km 592,6  
08740 S. Andreu de la Barca  
Spain  
Phone: +34 93 6533-500  
Fax: +34 93 6533-508  
e-mail: dinamica@dinamica.net  
www.dinamica.net

## Sales partner Austria



Haberkorn GmbH  
Modecenterstraße 7  
1030 Wien  
Austria  
Phone: +43 1 74074-0  
Fax: +43 1 74074-99  
e-mail: antriebselemente@haberkorn.com  
www.haberkorn.com

## Sales partner Great Britain



Transmission Developments Co. (GB) Ltd  
Dawkins Road  
Poole, Dorset, BH15 4HF  
Great Britain  
Phone: +44 1202 675555  
Fax: +44 1202 677466  
e-mail: sales@transdev.co.uk  
www.transdev.co.uk

Do you need further  
information on the Mulco product  
range? Please contact us.

Mulco-Europe EWM  
Phone: +49 5131 4522-0  
Fax: +49 5131 4522-110  
e-mail: info@mulco.net  
www.mulco.net

