

BRECO[®] - Timing Belts Simple. Good. Reliable.





Keeping things moving!

Timing belts from BRECO are high-quality, versatile and reliable drive elements. Continuous development and refinement of our production processes, the use of high-grade raw materials and the resulting improvements in terms of product qualities relating to precision, power transfer and wear have all helped to elevate the timing belts marketed under the brand names BRECO® and BRECOFLEX® to premium-level products in the field of positive-fit drive elements.

The range of potential applications for polyurethane timing belts has increased in recent years. The availability of a wide choice of raw materials along with the options for modifying them to suit the widest range of operating conditions have and will have an impact on the further application and development potential of timing belts.

The importance of different chemical and mechanical properties of polyurethane timing belts can vary given the diversity of the potential fields of application. As a result, there is no such thing as an „all-rounder“, i.e. a timing belt which is equally well suited to simple and more challenging applications. However, there is one property that all timing belts must deliver at all times - and that is quality. The name BRECO stands for this quality.

With the BRECObasic®, users now have access to an inexpensive branded product for simple applications in linear and transport technology, e.g. in the glass and wood industries.

Staying safely on the move.



Contents	Page
The difference is BRECO	5
BRECObasic® - Simple. Good. Reliable.....	6
Coatings	10
Sales partners.....	12
Product catalogues.....	14
Warranties	15

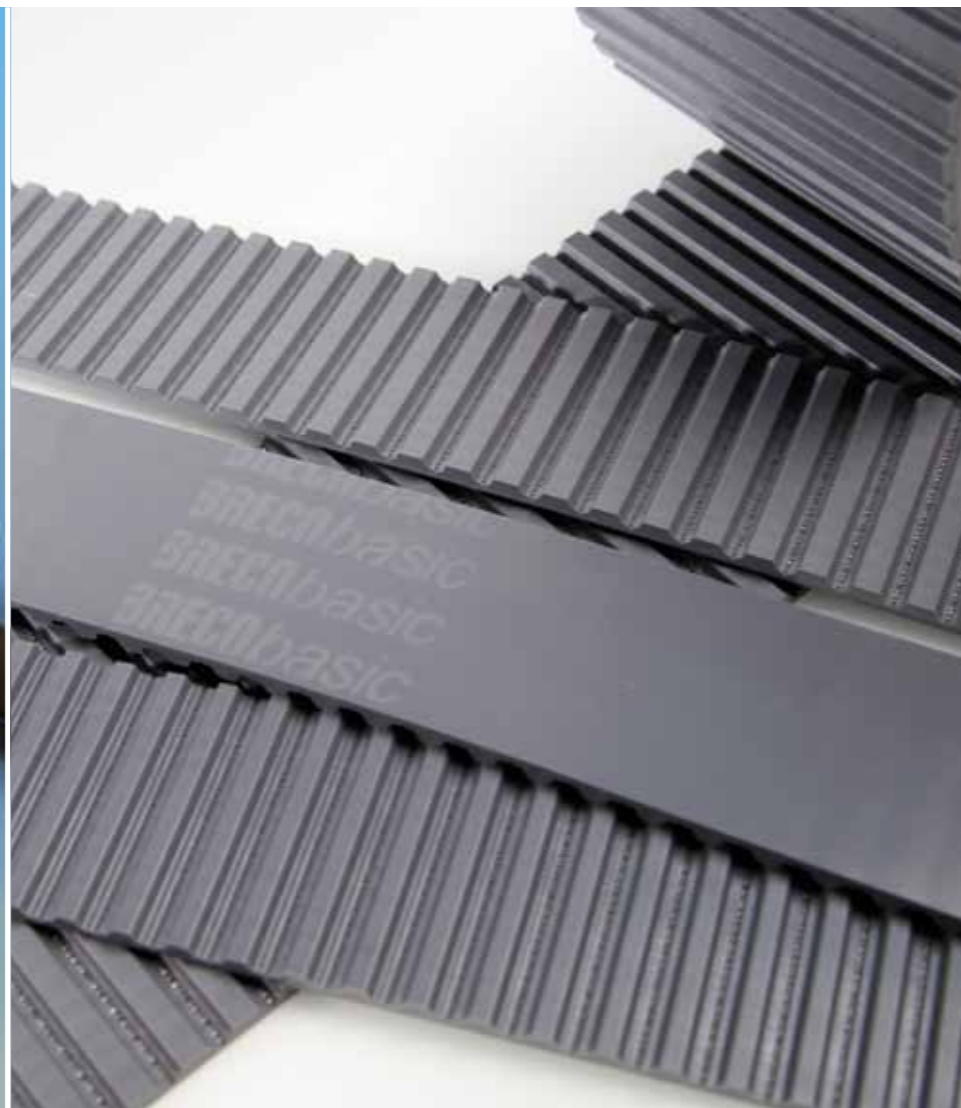

The difference is BRECO

The range of products offered by BRECO under the banner of the „BRECObasic“ brand is an inexpensive alternative for simple applications that require less than the full potential strength of standard-type BRECO® timing belts. The range is designed for applications that do not come with special demands relating e.g. to restricted tolerances, particular durability/resilience requirements or further processing options for the timing belts.

BRECObasic® timing belts are produced exclusively as a by-the-metre product and can be welded to form endless belts if required.

Like all other BRECO products, the BRECObasic® range stands for quality and reliability of operation.

Comparison of supply options	BRECObasic® (M/V) (AT10 BAS, T10 BAS)	BRECO® (M/V) (AT10, T10)
Special materials (polyurethane)	No	Yes
Special materials (tension member)	No	Yes
Special widths	No	Yes
Reduced longitudinal/lateral tolerance	No	Yes
Mechanical belt processing	No	Yes
Coating materials	Restrictions to the choice of coatings due to the particular production process	No restrictions
Standard colour	Anthracite	White
Colouring options	No	Yes
Individual labelling	No	Yes

BRECObasic® offers a tooth shear strength that is comparable to most commercially available timing belts. By contrast, the tooth shear strength of a standard BRECO® timing belt is around 20% higher, including in comparison to BRECObasic® belts.

Comparison of specific forces acting on the teeth – AT10 BAS and AT10

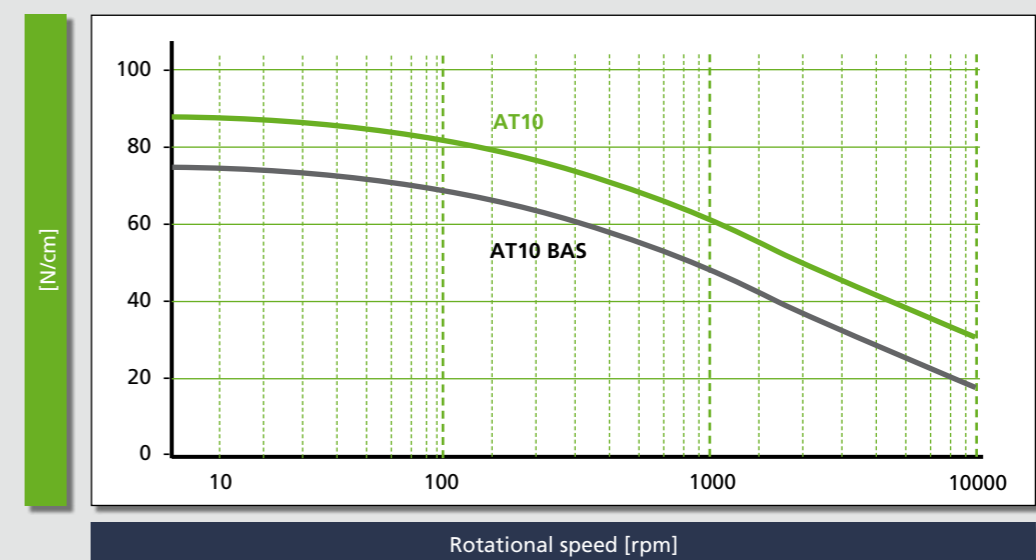

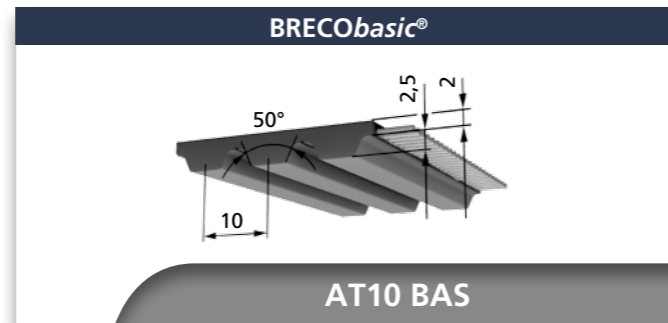

BRECO® AT10 BAS (M/V)		Specific tooth force			
R.p.m. n [min ⁻¹]	F _{tspez} [N/cm]	R.p.m. n [min ⁻¹]	F _{tspez} [N/cm]	R.p.m. n [min ⁻¹]	F _{tspez} [N/cm]
0	73,50	1200	47,20	3600	31,90
20	72,40	1300	46,20	3800	31,10
40	71,40	1400	45,20	4000	30,30
60	70,50	1500	44,30	4500	28,50
80	69,60	1600	43,40	5000	26,90
100	68,70	1700	42,60	5500	25,50
200	65,00	1800	41,80	6000	24,20
300	62,10	1900	41,00	6500	23,00
400	59,50	2000	40,30	7000	21,80
500	57,40	2200	39,00	7500	20,80
600	55,50	2400	37,80	8000	19,77
700	53,70	2600	36,60	8500	18,84
800	52,20	2800	35,50	9000	17,95
900	50,80	3000	34,50	9500	17,12
1000	49,50	3200	33,60	10000	16,32
1100	48,30	3400	32,70		

Belt widths b [mm]	AT10R3 BAS			AT10R4 BAS		
Production widths [mm]	96			100		
Possible cutting widths	16	32	64	25	50	75

AT10 BAS (M/V)	Available lengths and versions	
Standard delivery lengths (M)	50 or 100-metre roll	
Belt colour	anthracite	
Minimum length joined (V)	880 mm	Request minimum order value
PAZ	Available	

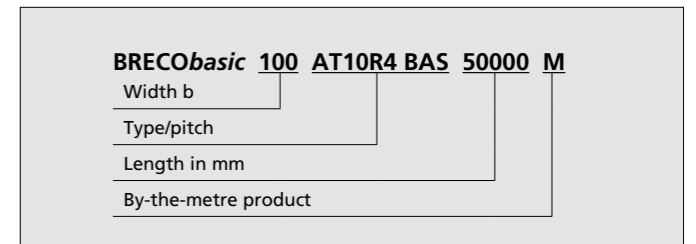

AT10 BAS (M/V)		Admissible tension cord strength F _{Tadm} / Specific elasticity / Belt weight								
Belt width		b [mm]	16	25	32	50	64	75	96	100
M	Basic tension member	F _{Tadm} [N]	2750	4250	5500	8500	11000	12750	16500	17000
	Specific elasticity	C _{spez} [N]	0,69·10 ⁶	1,06·10 ⁶	1,37·10 ⁶	2,12·10 ⁶	2,72·10 ⁶	3,18·10 ⁶	4,08·10 ⁶	4,25·10 ⁶
V	Basic tension member	F _{Tadm} [N]	1375	2125	2750	4250	5500	6375	8250	8500
Belt weight		[kg/m]	0,093	0,158	0,186	0,290	0,372	0,436	0,558	0,581

AT10 BAS (M/V)		Flexibility (minimum diameter)			
			M		V
 z _{min} d _{min}	Without contra-flexure	z _{min}	15	15	
		d _{min} [mm]	50	50	
 z _{min} d _{min}	With contra-flexure	z _{min}	25	25	
		d _{min} [mm]	120	120	

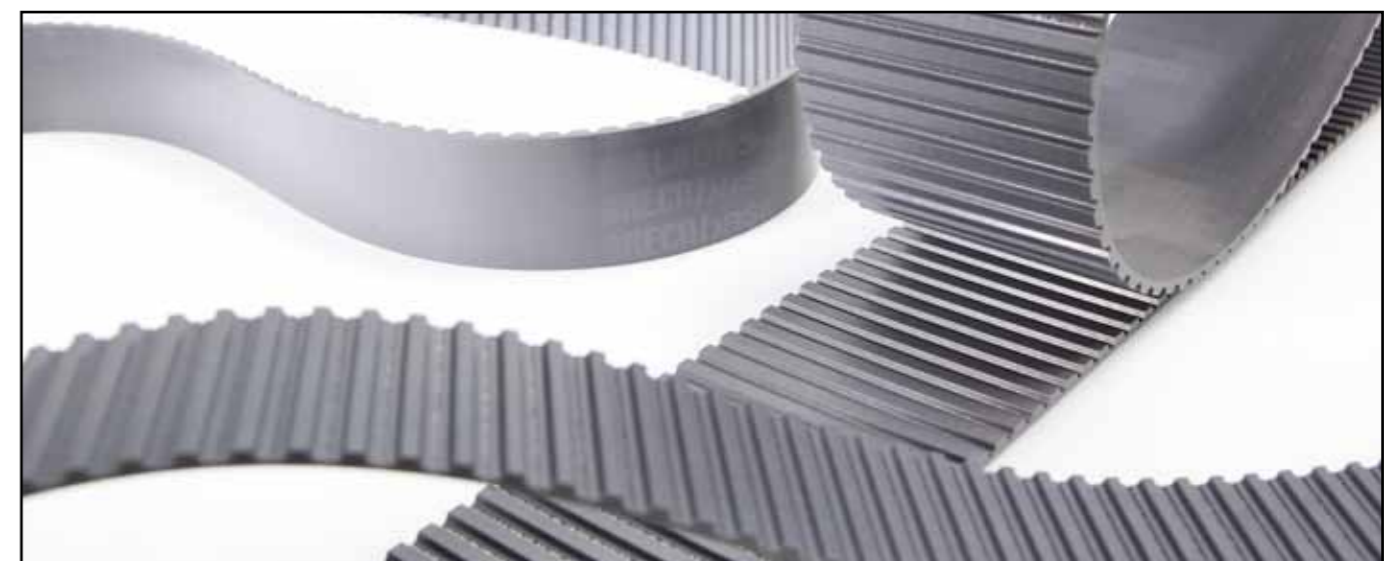

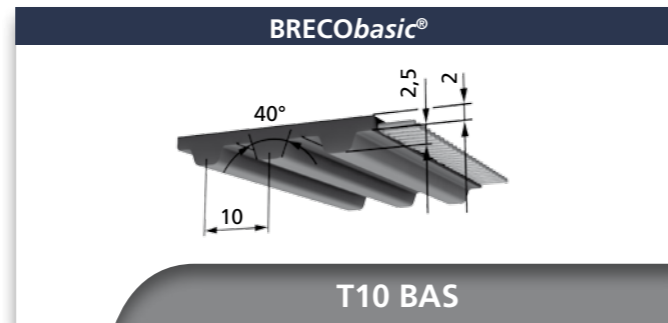

BRECO® T10 BAS (M/V)		Specific tooth force			
R.p.m. n [min ⁻¹]	F _{tpez} [N/cm]	R.p.m. n [min ⁻¹]	F _{tpez} [N/cm]	R.p.m. n [min ⁻¹]	F _{tpez} [N/cm]
0	50,50	1200	29,30	3600	20,70
20	49,00	1300	28,70	3800	20,30
40	47,70	1400	28,20	4000	19,86
60	46,60	1500	27,60	4500	18,91
80	45,70	1600	27,10	5000	18,06
100	44,80	1700	26,70	5500	17,28
200	41,40	1800	26,20	6000	16,58
300	39,10	1900	25,80	6500	15,93
400	37,20	2000	25,40	7000	15,33
500	35,70	2200	24,60	7500	14,76
600	34,40	2400	23,90	8000	14,24
700	33,30	2600	23,30	8500	13,74
800	32,40	2800	22,70	9000	13,28
900	31,50	3000	22,20	9500	12,84
1000	30,70	3200	21,70	10000	12,42
1100	30,00	3400	21,20		

Belt widths b [mm]	T10R3 BAS			T10R4 BAS		
Production widths [mm]	96			100		
Possible cutting widths	16	32	64	25	50	75

T10 BAS (M/V)	Available lengths and versions	
Standard delivery lengths (M)	50 or 100-metre roll	
Belt colour	anthracite	
Minimum length joined (V)	880 mm	Request minimum order value
PAZ	Available	

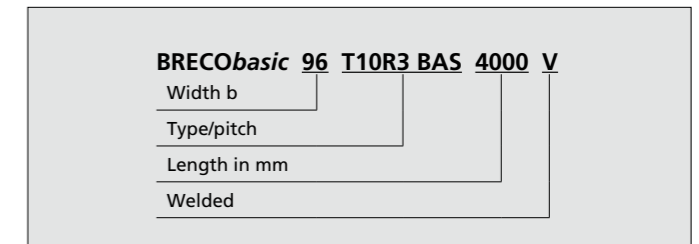

T10 BAS (M/V)		Admissible tension cord strength F _{Tadm} / Specific elasticity / Belt weight								
Belt width		b [mm]	16	25	32	50	64	75	96	100
M	Basic tension member	F _{Tadm} [N]	1400	2200	2800	4400	5600	6600	8400	8800
	Specific elasticity	C _{spez} [N]	3,5·10 ⁵	5,5·10 ⁵	7,0·10 ⁵	11,0·10 ⁵	14,1·10 ⁵	16,5·10 ⁵	21,1·10 ⁵	22,0·10 ⁵
V	Basic tension member	F _{Tadm} [N]	700	1100	1400	2200	2800	3300	4200	4400
Belt weight		[kg/m]	0,073	0,114	0,145	0,227	0,290	0,341	0,435	0,454

T10 BAS (M/V)		Flexibility (minimum diameter)		
			M	V
z _{min}	Without contra-flexure	z _{min}	12	12
		d _{min} [mm]	60	60
z _{min}	With contra-flexure	z _{min}	20	20
		d _{min} [mm]	60	60



Coatings for BRECObasic®-timing belts



Properties	
Colour	transparent
Standard thickness	2 mm
Min. pulley diameter [mm]	80
Material / Hardness	polyurethane / Approx. 85 Shore A
Tolerances	±0.25 mm
Temperature resistance	-20°C to +80°C
Chemical resistance	resistant to simple oils and grease, petrol, ozone
Potential applications	general transport tasks (glass, metal panels, mechanically aggressive parts)



Properties	
Colour	transparent
Standard thickness	2.4 mm, groove depth: 0.5 mm
Min. pulley diameter [mm]	80
Material / Hardness	polyurethane / Approx. 70 Shore A
Tolerances	±0.25 mm
Temperature resistance	-20°C to +80°C
Chemical resistance	resistant to simple oils and grease, petrol, ozone
Potential applications	general transport tasks in wet areas (water, oil)

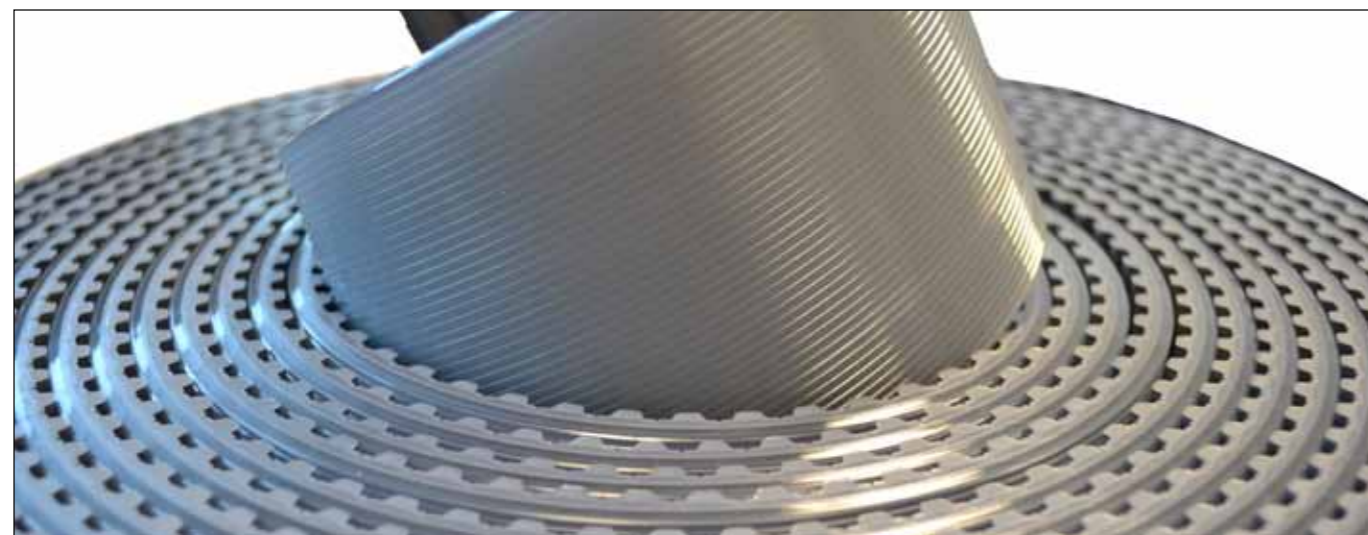

Coatings for BRECObasic®-timing belts



Properties	
Colour	yellow
Standard thickness	2 mm
Min. pulley diameter [mm]	60
Material / Hardness	Polyurethane foam / Approx. 55 Shore A
Tolerances	±0.25 mm
Temperature resistance	-10°C to +70°C
Chemical resistance	resistant to simple oils and grease, not water-resistant
Potential applications	feed and discharge lines on weighing units, vacuum transport conveyors, paper/textile/glass/wood industry



Properties	
Colour	blue-green
Standard thickness	4.5 mm
Min. pulley diameter [mm]	60
Material / Hardness	PVC, approx. 45 Shore A
Tolerances	±0.3 mm
Temperature resistance	-5°C to +70°C
Chemical resistance	limited resistance to solvents, oils and grease, resistant to acids and alkaline solutions, with the exception of very potent oxidants (such as concentrated sulphuric acid and nitric acid)
Potential applications	inclined conveyance, elevating conveyors, glass industry



Properties	
Colour	green
Standard thickness	0.5 mm
Material / Hardness	Polyamide
Tolerances	± 0.2 mm
Temperature resistance	-20°C to +50°C
Chemical resistance	Resistant to simple oils and grease
Potential applications	Reduced friction, e.g. when using supporting rails or guide rails

Anton Klocke
Antriebstechnik GmbH
 Senner Straße 151
 D-33659 Bielefeld
 phone: +49 521 950 05-01
 fax: +49 521 950 05-11
 www.klocke-antrieb.de
 info@klocke-antrieb.de



Germany

REIFF Technische Produkte GmbH
 Tübinger Straße 2-6
 D-72762 Reutlingen
 phone: +49 712 132 3-0
 fax: +49 712 132 3-318
 www.reiff-tp.de
 zahnriemen@reiff-gmbh.de



Germany

Wilhelm Herm. Müller GmbH & Co. KG
 Heinrich-Nordhoff-Ring 14
 D-30826 Garbsen
 phone: +49 513 145 22-0
 fax: +49 513 145 22-110
 www.whm.net
 info@whm.net



Germany

W. H. MÜLLER s.r.o.
 Pražákova 39
 CZ-61900 Brno
 phone: +420 543 211 008
 phone: +420 543 212 343
 fax: +420 541 217 468
 www.whm.cz
 whm@whm.cz



Czech Republic

Wilhelm Herm. Müller
 Polska Sp. z o.o.
 ul. Solna 20
 PL-85-862 Bydgoszcz
 phone: +48 523 490 715
 fax: +48 523 490 075
 www.whm.pl
 whm@whm.pl



Poland

Walter Rothermundt GmbH & Co. KG
 Am Tannenbaum 2
 D-41066 Mönchengladbach
 phone: +49 216 169 462-0
 fax: +49 216 166 446 9
 www.rothermundt.de
 info@rothermundt.de



Germany

Roth GmbH & Co. KG
 Andernacher Straße 14
 D-90411 Nürnberg
 phone: +49 911 995 21-0
 fax: +49 911 995 21-70
 www.roth-ing.de
 info@roth-ing.de



Germany

Aratron AB
 Smidesvägen 4-8
 SE-17141 Solna
 phone: +46 840 416 00
 fax: +46 898 428 1
 www.aratron.se
 info@aratron.se



Sweden

ARATRON AS
 Postboks 214 Holmlia
 N-1204 Oslo
 phone: +47 231 916 60
 fax: +47 231 916 61
 www.aratron.no
 firmapost@aratron.no



Norway

Movetec Oy
 Hannuksentie 1
 FIN-02270 Espoo
 phone: +35 895 259 230
 fax: +35 895 259 233 3
 www.movetec.fi
 info@movetec.fi



Finland

BONDY LMT A/S
 Hassellunden 14
 DK-2765 Smørum
 phone: +45 701 514 14
 fax: +45 446 414 16
 www.bondy.dk
 info@bondy.dk



Denmark

Hilger u. Kern GmbH
Antriebstechnik
 Käfertaler Straße 253
 D-68167 Mannheim
 phone: +49 621 370 5-0
 fax: +49 621 370 5-403
 www.hilger-kern.com
 antriebstechnik@hilger-kern.de



Germany

Haberkorn GmbH
 Modecenterstraße 7
 A-1030 Wien
 phone: +43 174 074-0
 fax: +43 174 074-99
 www.haberkorn.com
 info.wien@haberkorn.com



Austria

Dinámica Distribuciones S.A.
 Ctra. No. II, km 592,6
 E-08740 S. Andreu de la Barca
 phone: +34 936 533 500
 fax: +34 936 533 508
 www.dinamica.net
 dinamica@dinamica.net



Spain

BRECOflex Co., L.L.C.
 222 Industrial Way West
 USA-Eatontown, NJ 07724
 phone: +1 732 460-9 500
 fax: +1 732 542-6 725
 www.brecoflex.com
 info@brecoflex.com



USA

MULCO®
 THE POWER OF A WELL-MESHED GROUP.

Distribution partner

Binder Magnetic
 1, Allee des Barbanners
 F-92632 Gennevilliers-Cedex
 phone: +33 146 138 080
 fax: +33 146 138 099
 www.binder-magnetic.com
 info@binder-magnetic.fr



France / Belgium

Transmission Developments Co. (G.B.) LTD
 Dawkins Road, Hamworthy
 GB-Poole Dorset BH15 4HF
 phone: +44 120 267 555 5
 fax: +44 120 267 746 6
 www.transdev.co.uk
 sales@transdev.co.uk



Great Britain

BRECO not only believes in high standards of quality for production, but also when it comes to advice and service concerning all aspects of polyurethane timing belt technology. Our sales partners are all specialists in this field and can offer you the very best customer support.

BRECO is a member of Mulco Europe EWIV, a European economic interest grouping. All of its members are seen as pioneers in the field of polyurethane timing belt technology. The trust that has grown during the course of many years and the intensive level of cooperation between members was and will remain the basis for the development of innovative drive solutions for general engineering in the future.

BRECO® and BRECOFLEX® timing belts – safety in motion.

Available product catalogues - for every application the right product

BRECO® and BRECOFLEX® timing belts

- General information (application and calculation notes)
- Endless timing belts (BRECOFLEX®)
- Open length timing belts (BRECO® M)
- Endless joined timing belts (BRECO® V)
- Timing belt lock for AT10, T10

ATN-System - BRECO® timing belts for transport technology

- General information (application information and notes on calculations)
- ATN timing belts
- ATN timing belt lock
- ATN standard profile connection
- ATN profiles
- ATN components

BRECO® und BRECOFLEX® flat belts

- General information
- Endless flat belts (BRECOFLEX®)
- Open length timing belts (BRECO® M)
- Open length flat belts (BRECO® M)
- Endless joined flat belts (BRECO® V)

Finishing of timing belts

- Coatings for polyurethane timing belts
- Mechanical rework of coatings
- Mechanical rework of timing belts
- Welded-on profiles
- High strength profile connection

Components

- General information
- Timing pulleys
- Synchronising pulleys with tensioners
- Synchronising shafts
- Tension rollers
- BRECO® fix-clamping elements

BRECObasic®-timing belts

- Product range
- Coatings for BRECObasic® timing belts

Further information about:

- Sales partners
- New products and developments
- Available catalogues can be found at www.breco.de

Warranty

All information has been compiled with the utmost care and attention and reflects the current state of knowledge. However, we would like to particularly draw your attention to the fact that all technical data is quoted subject to tolerances and must not be interpreted as a guaranteed delivery specification. We reserve the right to make technical changes as part of our continuous product development process.



BRECO® and BRECOFLEX® are registered trademarks of BRECO Antriebstechnik Breher GmbH & Co. KG.

© 2012 BRECO Antriebstechnik Breher GmbH & Co. KG

All rights withheld.
No parts of this catalogue may be reproduced.
Printed in Germany, engl. version 25/2012/1500

